

GA2104000 ON DMD

- NOTES: 1. CUSTOMER MUST SUPPLY MTG. ARRANGEMENT WITH AT LEAST 2.00" [51] MIN. BELT TAKE-UP.
 2. ALL DIMENSIONS GIVEN IN INCHES.
 3. LEAVE AT LEAST 12.00" [305] MIN. CLEARANCE ON ALL SIDES FOR PROPER AIR CIRCULATION.
 4. CLOCKWISE ROTATION.

5. NET WEIGHT: 570 LBS. [259kg]
 6. ALL UNSPECIFIED TOLERANCES: XXX = ±.03 [1]
 XX = ±.12 [3]
 X = ±.25 [6]
 7. DIMENSIONS IN [] ARE MILLIMETER DIMENSIONS UNLESS OTHERWISE SPECIFIED.

CONSTANT SPEED UNLOADERS

AIR INLET FILTERS

INTERCOOLER RELIEF VALVE

AIR FLOW

AIR OUTLET 1-1/4" NPT

5/16" [8] O.D. MIN. TUBING BY CUSTOMER

1/4" NPT PIPE THD. TO RECEIVER

CONSTANT SPEED UNLOADER AUX. VALVE TO BE MOUNTED IN A VERTICAL POSITION ON RECEIVER BY CUSTOMER

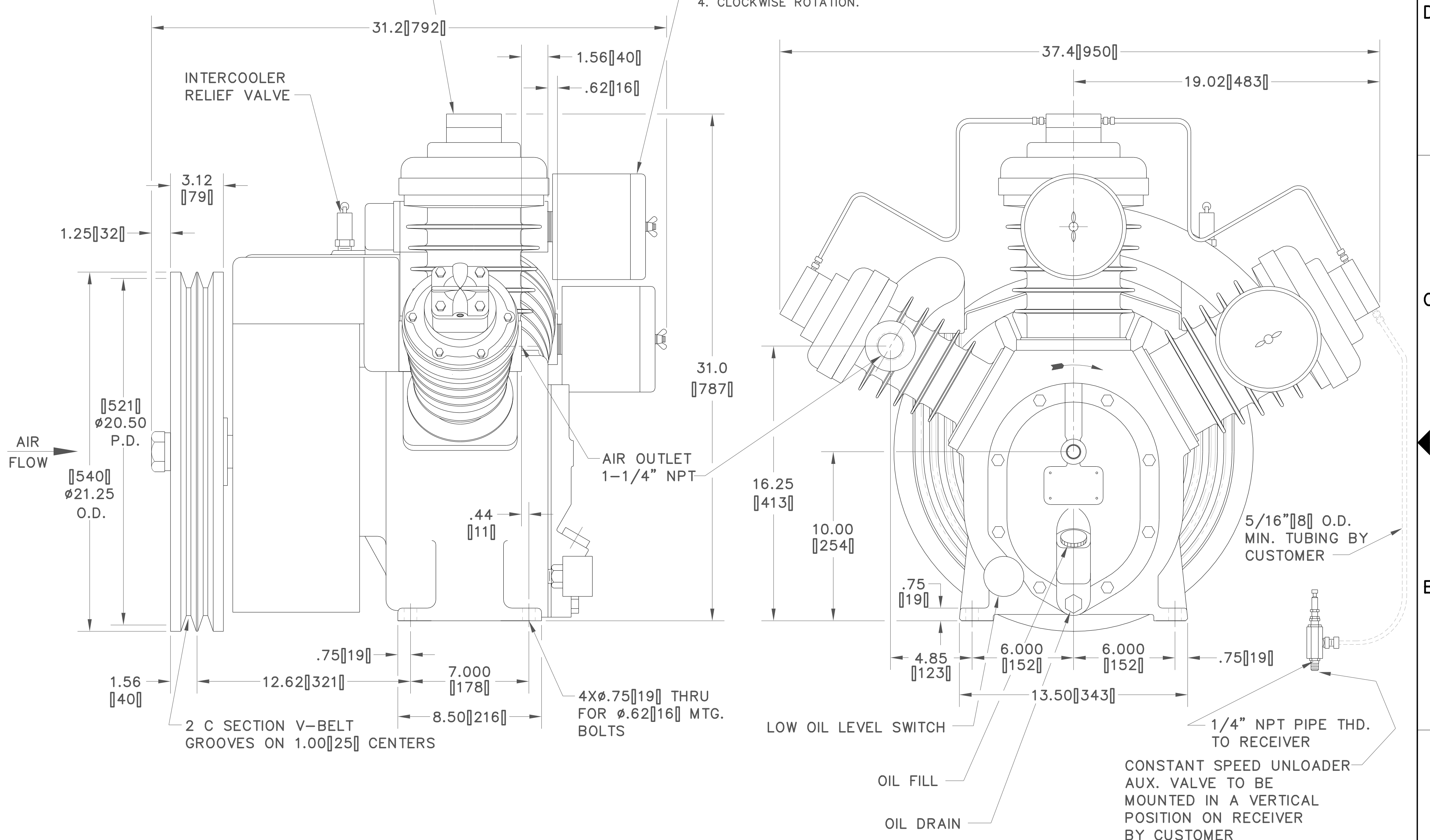

APPROVED FOR: _____
 IR ORDER NO. _____
 CUSTOMER: _____
 CUSTOMER ORDER NO. _____
 PER: _____ DATE: _____

SIZE: _____
 MODEL: _____
 PISTON DISPLACEMENT: _____
 SPEED RPM: _____
 DISCHARGE PRESSURE RATING: _____
 ACTUAL DELIVERY: _____
 REGULATION: _____

PROPRIETARY NOTICE
 THIS DOCUMENT CONTAINS CONFIDENTIAL AND TRADE SECRET INFORMATION, IS THE PROPERTY OF INGERSOLL-RAND COMPANY, AND IS GIVEN TO THE RECEIVER IN CONFIDENCE. THE RECEIVER BY RECEPTION AND RETENTION OF THE DOCUMENT ACCEPTS THE DOCUMENT IN CONFIDENCE AND AGREES THAT, EXCEPT AS AUTHORIZED IN WRITING BY INGERSOLL-RAND COMPANY, IT WILL (1) NOT USE THE DOCUMENT OR ANY COPY THEREOF OR THE CONFIDENTIAL OR TRADE SECRET INFORMATION THEREIN; (2) NOT COPY THE DOCUMENT; (3) NOT DISCLOSE TO OTHERS EITHER THE DOCUMENT OR THE CONFIDENTIAL OR TRADE SECRET INFORMATION THEREIN; AND (4) UPON COMPLETION OF THE NEED TO RETAIN THE DOCUMENT, OR UPON DEMAND, RETURN THE DOCUMENT, ALL COPIES THEREOF, AND ALL MATERIAL COPIED THEREFROM.
 Copyright © 1992
 Ingersoll-Rand Company
 All Rights Reserved
 WARNING: The export or reexport of this drawing or a product produced by this drawing is subject to U.S. Export Administration Regulations and other applicable governmental restrictions or regulations.

INGERSOLL-RAND Co.
 RECIPROCATING COMPRESSOR DIVISION
 SMALL COMPRESSOR BUSINESS UNIT
 CAMPBELLSVILLE, KY

THIRD ANGLE PROJECTION
 SCALE 1/4" = 1"

REF. 15T BARE
 TITLE GENERAL ARRANGEMENT
 SIZE C
 DWG NO. GA2104000
 REV 02
 SHEET 1 OF 1