

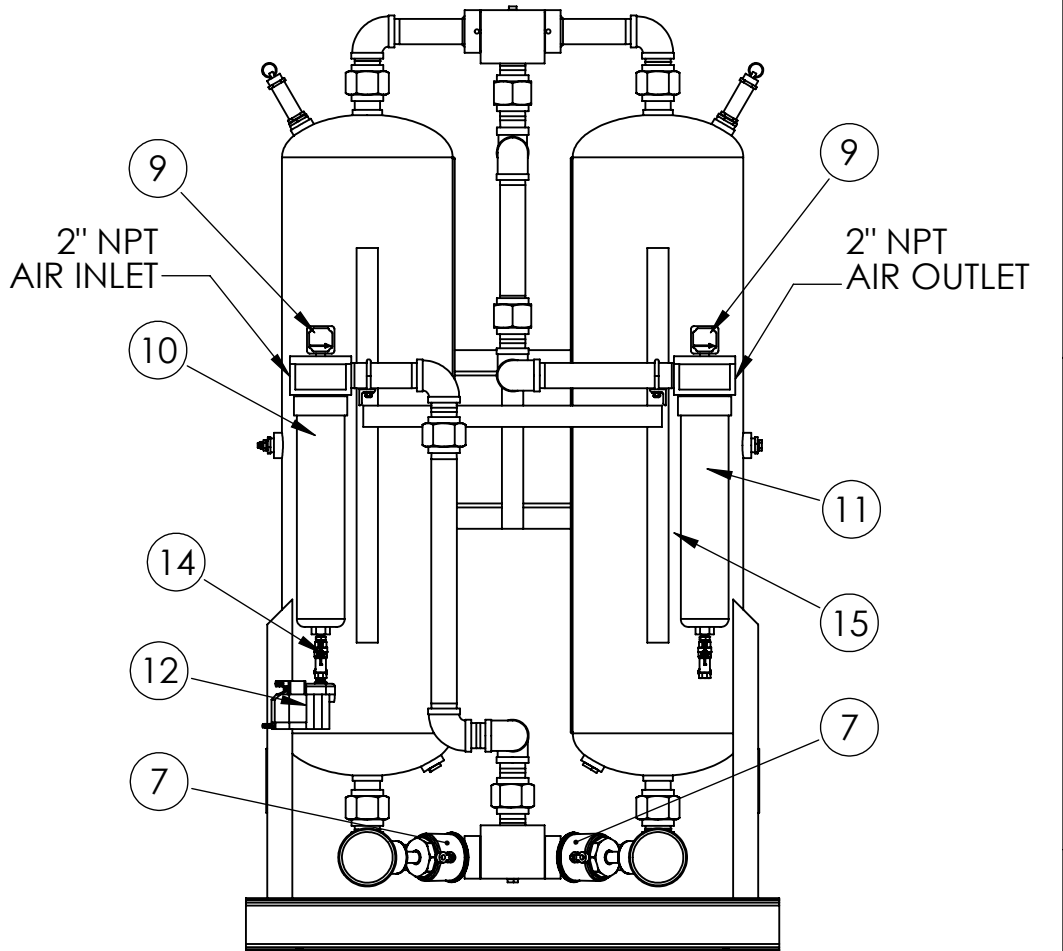

ITEM NO.	QTY.	STOCK #	Description
1	4	AG3289901	SCREEN ASSY, 2" NPT
2	2	AG3482377	VALVE, SAFETY RELIEF, 1"
3	2	AG3935114	DIFFUSER SCREEN, VESSEL DESSICANT BED
4	2	AG3933854	VALVE, SHUTTLE
5	2	AG3480089	GAUGE, PRESSURE, 0-200 PSIG
6	1	AG3935154	ELEMENT, PARTICULATE, F/PILOT AIR FILTER
7	2	AG3934929	VALVE, ANGLE BODY, 2" BRNZ, NC
8	2	AG3934192	MUFFLER, 2" MPT THREADED, AIR DRYER TYPE, WITH RELIEF
9	2	AG3940710	DIFFERENTIAL PRESSURE GAUGE
10	1	AG3488012	ELEMENT, COALESCING
11	1	AG3488011	ELEMENT, PARTICULATE
12	1	AG3939988	CONDENSATE DRAIN, ZERO LOSS, ELECTRIC, SMART GUARD-AI, 115V-230 PSL- 1/2" NPT
13	1	AG1230201	THREADED PIPE NIPPLE, BRASS CLOSE 1/2"
14	2	AG3942303	VALVE, 1/2" FPT, BALL-Y-STRAINER COMBO
15	612 LBS	AG3319301	DESICCANT, ACTIVATED ALUMINA
16	1	AG3234801	REGULATOR, 1/4" NPT



UNLESS OTHERWISE SPECIFIED:		NAME	DATE	 <b>COMPRESSED AIR AND GAS PRODUCTS</b> 323 CRISP CIRCLE MARYVILLE TENNESSEE 37801 PHONE: 865-681-7066 FAX: 865-681-7069
DIMENSIONS ARE IN INCHES TOLERANCES: FRACTIONAL: ± 0.125 ANGULAR: ± 0.5° TWO PLACE DECIMAL ± .03 THREE PLACE DECIMAL ± .003		DRAWN	BH	
 THIRD ANGLE PROJECTION		CHECKED	MS	7/8/15
		ENG APPR.		
MATERIAL		MFG APPR.		
FINISH		Q.A.		
DO NOT SCALE DRAWING		COMMENTS:		TITLE: DRYER, DESICC, AHLD-600, PACK B, 1 PRE & AFTER FILTER, MECHANICAL SPARE PARTS
		SIZE	DWG. NO.	
		<b>B</b>	AG9933440-B SPARE	
		SCALE: 1:50	WEIGHT:	SHEET 1 OF 1

**PROPRIETARY AND CONFIDENTIAL**  
 THE INFORMATION CONTAINED IN THIS DRAWING IS THE SOLE PROPERTY OF AIRCEL LLC. ANY REPRODUCTION IN PART OR AS A WHOLE WITHOUT THE WRITTEN PERMISSION OF AIRCEL LLC IS PROHIBITED.