

| REV | DESCRIPTION | ECN # | CHG BY | DATE | APP'D |
|-----|------------------------------|-------|--------|----------|-------|
| A | UPDATED PART NUMBER, WAS CSL | 15527 | EZR | 02/14/19 | TAS |
| B | UPDATED ELEMENT SPECS | 17839 | TAS | 12/04/19 | NAD |

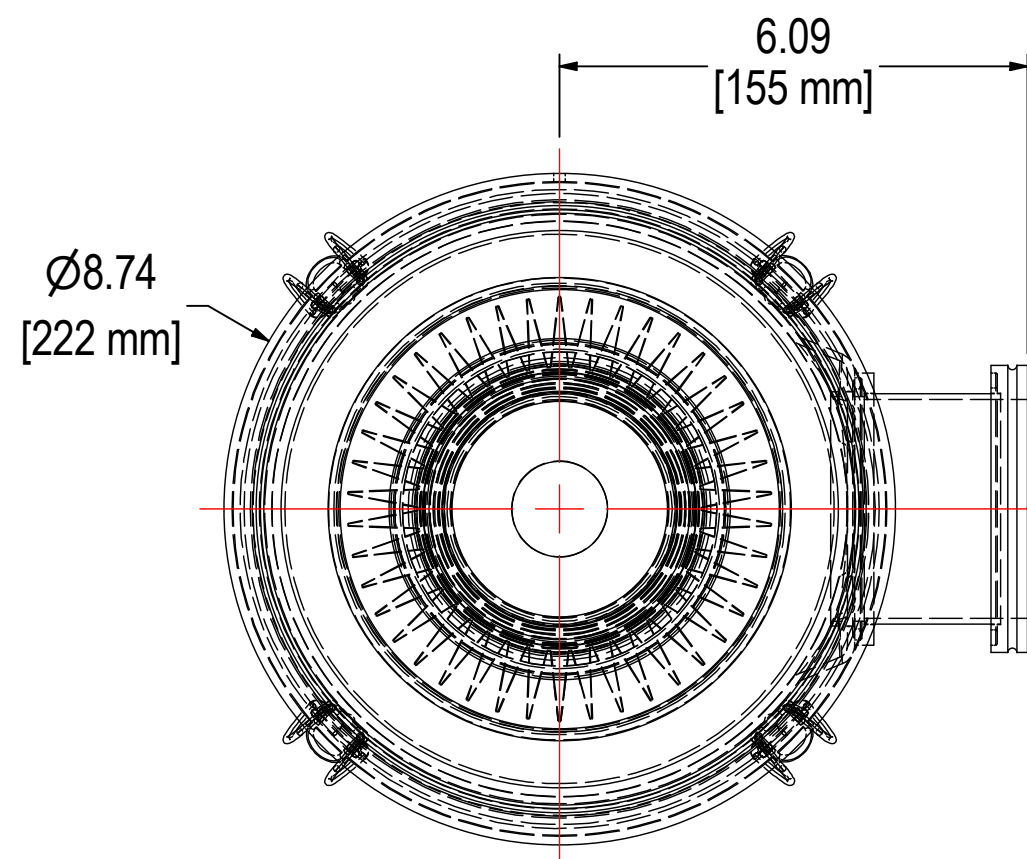

FLANGE FACE SURFACES TO BE FREE OF SCRATCHES, DIVOTS, OR ANY DEFORMATION THAT AFFECTS SEAL. FLANGE FACES TO BE PROTECTED DURING SHIPMENT.

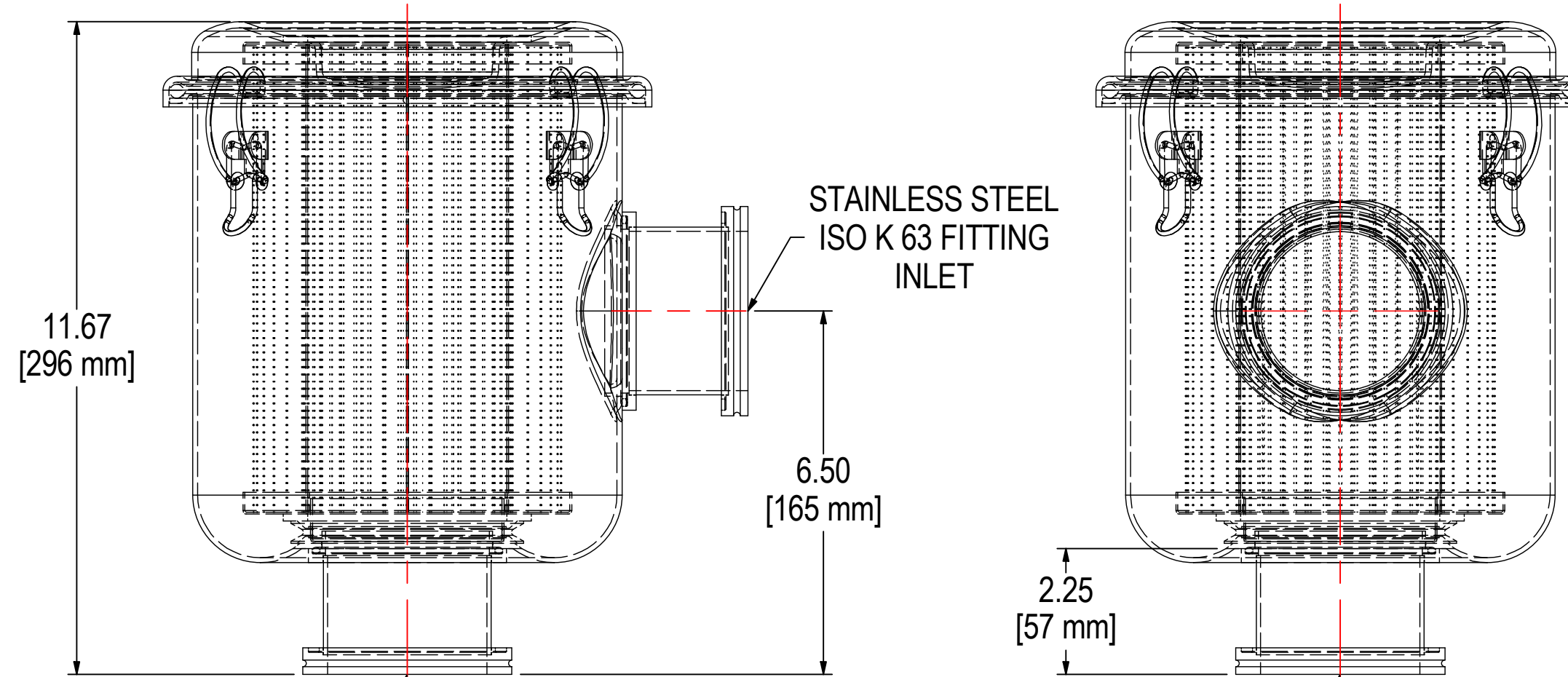

FLANGE FACE SURFACES TO BE FREE OF SCRATCHES, DIVOTS, OR ANY DEFORMATION THAT AFFECTS SEAL. FLANGE FACES TO BE PROTECTED DURING SHIPMENT.

NOTES & SPECIFICATIONS:

1. FLANGES TO BE PROTECTED DURING PRODUCTION & SHIPMENT.
2. UNIT TO BE HELIUM LEAK TESTED TO 1×10^{-5} mbar L/s.

| ELEMENT SPECS | | |
|---------------|---------------------|------------------------|
| PART NUMBER | 851 | |
| MATERIAL | POLYESTER | |
| FLOW RATE | 290 CFM | 493 m ³ /hr |
| SURFACE AREA | 4.8 ft ² | 0.4 m ² |
| I.D. | 3.50" | 89mm |
| O.D. | 5.88" | 149mm |
| HEIGHT | 8.69" | 221mm |



THE INFORMATION CONTAINED HEREIN IS CONFIDENTIAL AND THE PROPERTY OF SOLBERG MANUFACTURING INC. AND IT IS FURNISHED TO YOU WITH THE EXPRESS UNDERSTANDING THAT IT WILL NOT BE REPRODUCED, COPIED IN ANY MANNER, LOANED OR OTHERWISE TRANSFERRED TO OTHERS ENTIRELY OR IN PART, NOR USED FOR ANY PURPOSE OTHER THAN FOR WHICH IT WAS FURNISHED. IT WILL BE RETURNED UPON REQUEST TO SOLBERG MANUFACTURING INC. THE ABOVE RESTRICTION IS IN ADDITION TO, AND DOES NOT IN ANY WAY ALTER, ANY OTHER RESTRICTIONS WHICH MAY APPLY TO THE INFORMATION CONTAINED HEREIN.

TOLERANCES
 DIMENSIONS ARE FOR REFERENCE ONLY. ALL DIMENSIONS ARE SUBJECT TO CHANGE UPON PRODUCTION.
 UNLESS OTHERWISE SPECIFIED:
 -DIMENSIONS ARE IN INCHES
 -REF: APPROXIMATE DIMENSIONS, NO TOLERANCES APPLY
 -FINISH: BREAK EDGES TO .005-.020 RADIUS/CHAMFER

| | | |
|---------------------------------|----------------------------------|--------------------------------------|
| MODEL #: WL-851-K63B | MATERIAL: CARBON STEEL | FINISH: BLACK POWDER |
| MODEL NUMBER: WL-851-K63B | SHEET: 1 OF 2 | |
| DESCRIPTION: WL-851-K63B, BLACK | | |
| PROJECT: | DRAWN BY: CRW DATE: 3/18/2013 | APPROVED BY: M.C. DATE: 3/18/2013 |
| | | REV: B |