

| REV | DESCRIPTION | ECN # | CHG BY | DATE | APP'D |
|-----|--|---------|--------|----------|-------|
| A | UPDATED INTERNAL COMPONENTS | - | CMA | 06/16/09 | MJC |
| B | UPDATED THREAD DESIGNATION, WAS M12 | - | CRW | 02/21/11 | MJC |
| C | CHANGED DRAIN FITTING | PER MJC | CRW | 02/02/12 | MJC |
| D | CHANGED DRAIN SIZE, WAS 1/4" | PER MJC | CRW | 08/30/12 | MJC |
| E | UPDATED DRAIN FITTING | - | EZR | 02/27/13 | CRW |
| F | UPDATED BALL FLOAT TO BULLET STYLE | 2876 | JEB | 01/17/14 | CRW |
| G | UPDATED DRAIN, WAS 1/2" BULKHEAD/CONVERTED TO 3D | 14952 | EZR | 11/20/18 | TAS |
| H | UPDATED HOOK CLAMPS FROM PT HOOK CLAMP | DCR127 | NAS | 08/16/19 | NAD |
| I | ADDED FLOAT SEAL INSERT | 17082 | JEB | 09/02/19 | TAS |
| J | UPDATED BUCKET DRAIN MATERIAL, WAS 316 SS | 21415 | NAS | 03/08/21 | NAD |
| K | REMOVED NOTE | PRJ 682 | NAS | 03/22/21 | EZR |

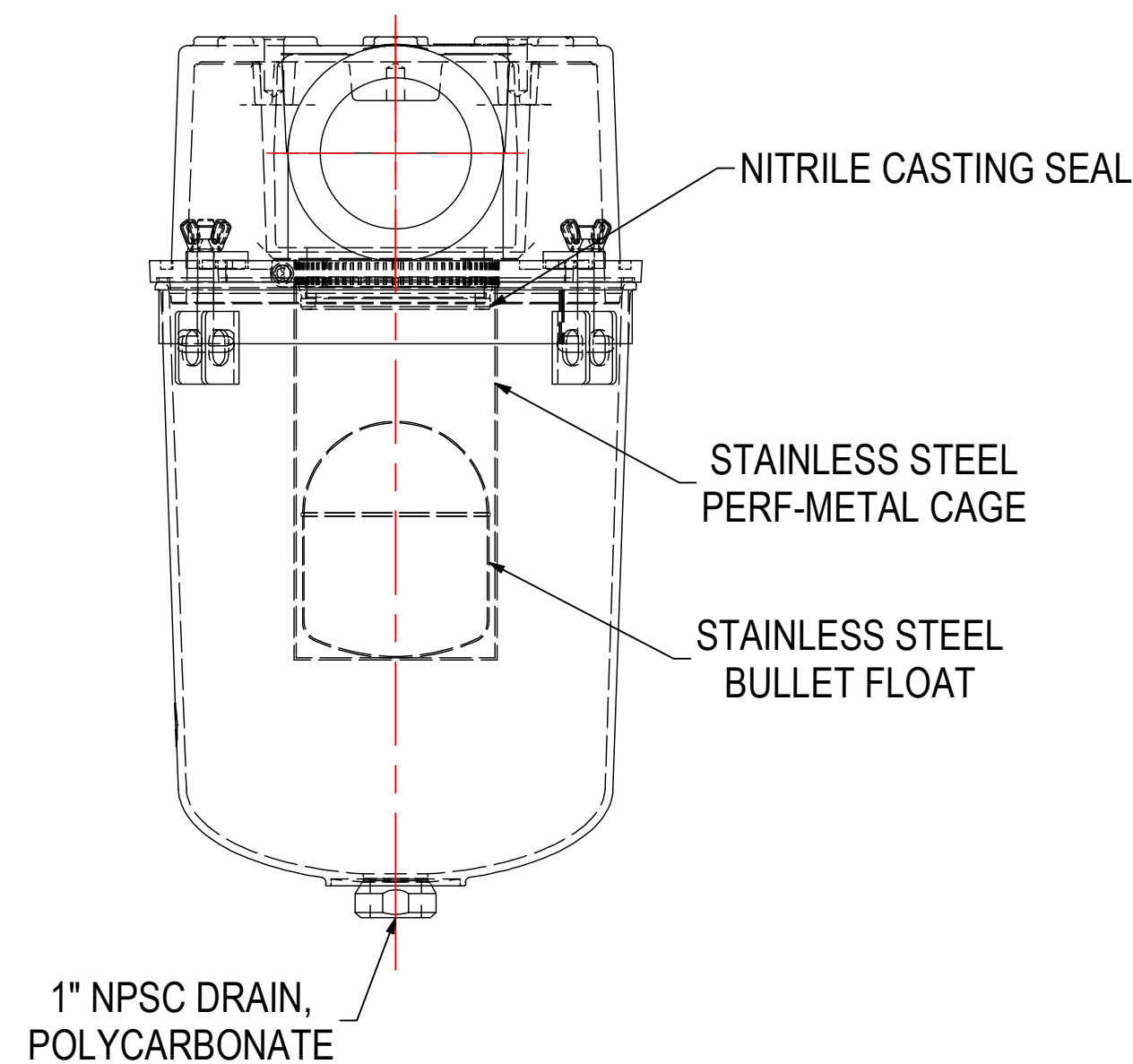
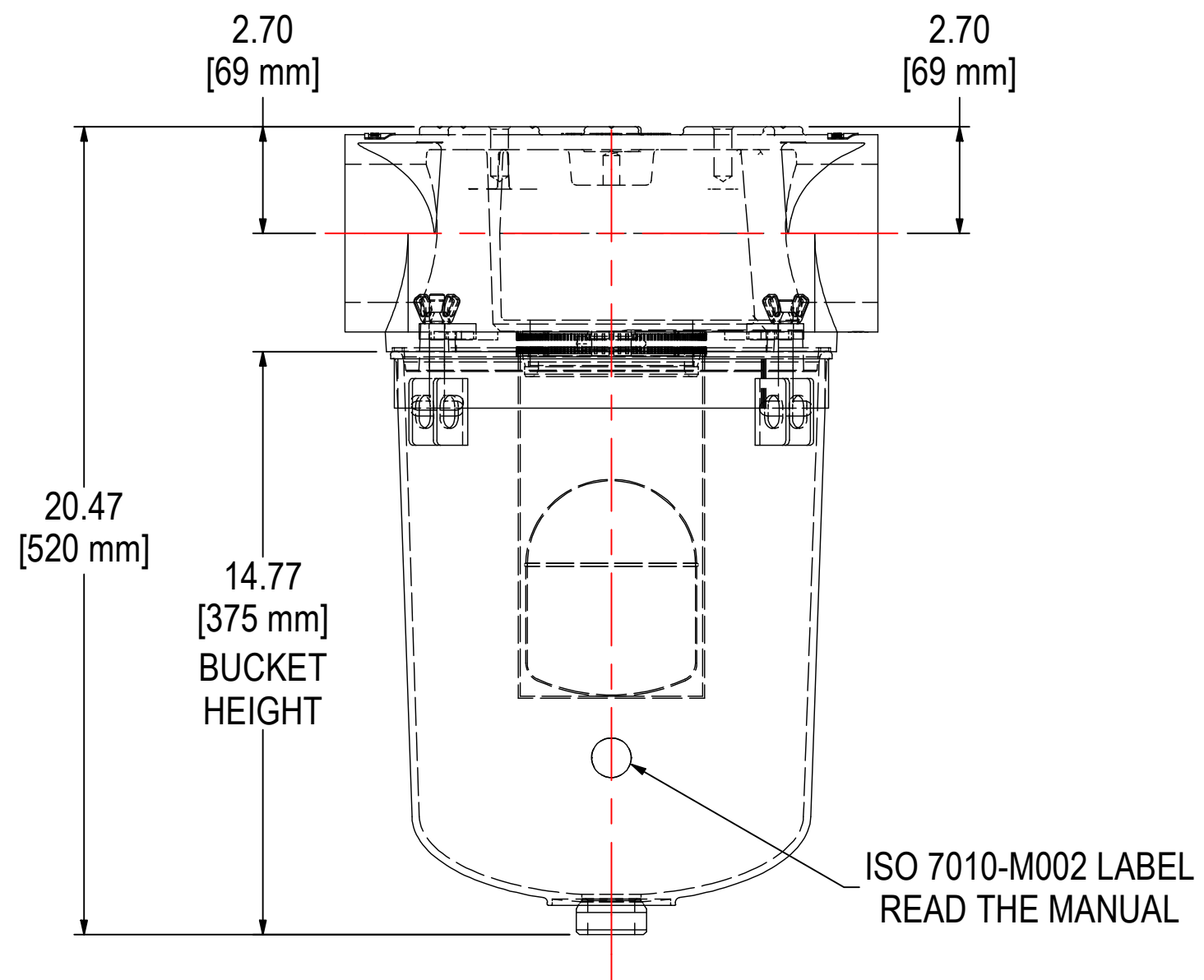
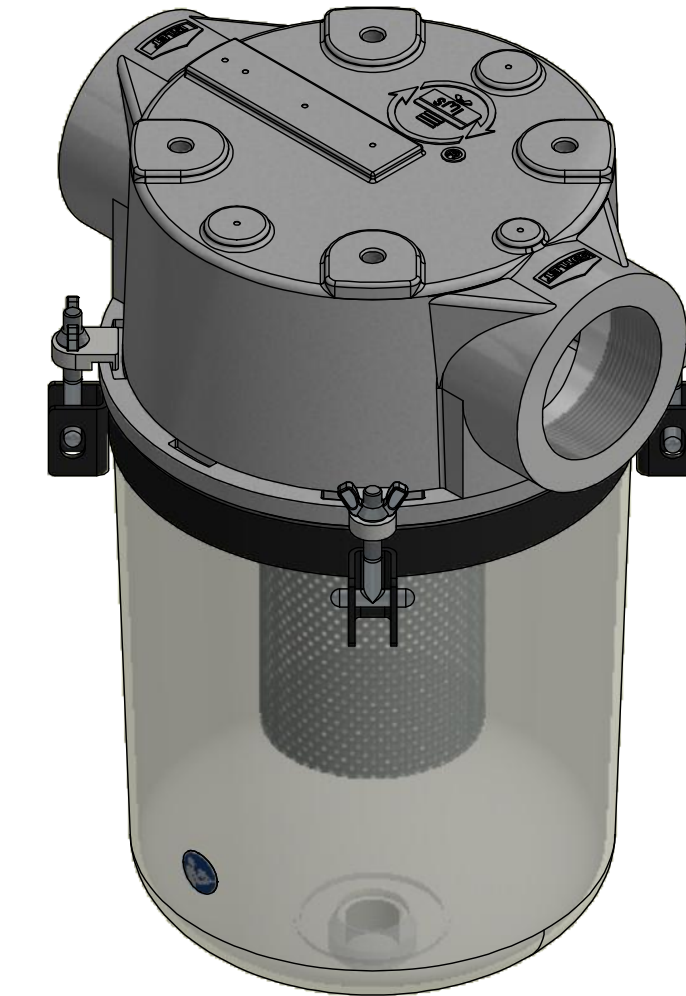

| | | | |
|------------------------|----------------------------------|---|------------------|
| MODEL #: STS-300C | MATERIAL: VARIES | FINISH: VARIES | SHEET: 1 OF 1 |
| MODEL NUMBER: STS-300C | | DESCRIPTION: STS-300C, 1" NPS-C POLYCARBONATE DRAIN, CLEAR BUCKET | |
| PROJECT: SD13374 | DRAWN BY: CRW DATE: 1/11/2008 | APPROVED BY: MJC DATE: 1/11/2008 | REV: K |