

REVISIONS					
ZONE	REV	ECN	DESCRIPTION	DATE	APPD
	A	1008708	ORIGINAL RELEASE	2015AUG21	J.WANG
3-A1	B	1201505	ADD DIM 665.0	2017FEB22	XH.ZHONG
4-A1	B	1201505	ADD DIM 655.0		
	C	1280411	UPDATED NOTE 12	2017DEC12	M.PRASHANT

NOTES:

- WEIGHT (APPROXIMATE): RS30i - 1045 KG (2304 LBS)
RS37i - 1095 KG (2414 LBS)
RS30i TAS - 1150 KG (2535 LBS)
RS37i TAS - 1200 KG (2646 LBS)
RS30n - 1095 KG (2414 LBS)
RS37n - 1145 KG (2524 LBS)
RS30n TAS - 1200 KG (2646 LBS)
RS37n TAS - 1250 KG (2750 LBS)
- USE FORK LIFT TUBES FOR MACHINE LIFTING.
- COOLING AIR FLOW: 60HZ-6900M3/HOUR (4060 CFM)
50HZ-7200M3/HOUR (4237 CFM)
- PIPE CONDENSATE DRAIN LINES SEPARATELY TO BASE DUE TO DIFFERENCES IN DRAIN PRESSURES. READ OPERATIONS MANUAL AND CHECK LOCAL REGULATIONS.
- LUBRICANT FILL QUANTITY: 13.7 LITRES (3.7 US GALLONS)
- RECOMMENDED CLEARANCE ON 3 SIDES 1 METER (40 INCHES); THE STARTER BOX SIDE IS 1.2 METERS (47 INCHES) OR MINIMUM AS REQUIRED BY LATEST NATIONAL ELECTRICAL CODE OR APPLICABLE LOCAL CODES.
- EXTERNAL PIPING SHOULD NOT EXERT ANY UNRESOLVED MOMENTS OR FORCES ON UNIT. USE PIPE OF EQUAL OR GREATER SIZE AT DISCHARGE LOCATION OF UNIT.
- THERE SHOULD BE NO PLASTIC OR PVC PIPING ATTACHED TO THIS UNIT OR USED FOR ANY LINES DOWNSTREAM.
- REMOVE THE ISOLATION MOUNT RESTRAINTS BEFORE THE INITIAL START. THE RESTRAINTS CAN BE DISCARDED.
- FIELD INSTALLED DUCTING TO AND FROM COMPRESSOR CANNOT ADD MORE THAN 6MM (.25 INCH) OF WATER TOTAL AIR RESISTANCE.
- UNIT HAS AN INTERNAL DISCHARGE CHECK VALVE, EXTERNAL CHECK VALVE NOT REQUIRED. ISOLATION VALVE REQUIRED WITHIN 915 MM (36 INCHES) OF THE COMPRESSOR DISCHARGE.
- COMPRESSOR MUST BE INSTALLED ON A LEVEL FLOOR CAPABLE OF SUPPORTING ENTIRE CONTACT SURFACE OF THE BASE FRAME. COMPRESSOR SHOULD BE BOLTED TO THE FLOOR WITH FOUR (4) M16 (3/4 INCH) BOLTS USING HOLES SHOWN ON SHEET 5. SEAL BASE TO FLOOR WITH CORK OR RUBBER.
- DO NOT PIPE INTO A COMMON HEADER WITH A RECIPROCATING COMPRESSOR. UNLESS RECIP COMPRESSOR UTILIZES A DISCHARGE PULSATION DAMPENERS.
- DENOTES CENTER OF GRAVITY.
- SIZING OF ELECTRICAL COMPONENTS NOT SUPPLIED BY INGERSOLL-RAND IS THE RESPONSIBILITY OF THE CUSTOMER AND SHOULD BE DONE IN ACCORDANCE WITH THE INFORMATION ON THE COMPRESSOR DATA PLATE, NATIONAL AND LOCAL ELECTRIC CODES.
- A BLANK GLAND PLATE IS PROVIDED FOR ELECTRICAL POWER INLET AS INDICATED.
- WHEN INSTALLED INDOORS IN A CONFINED SPACE, THE COOLING AIR INLET OR EXHAUST MUST BE DUCTED AWAY FROM UNIT TO PREVENT RECIRCULATION OF HOT EXHAUST AIR.
- CONNECTION LEGEND
- ALL 60 Hz CONNECTIONS ARE NPT (UNLESS SPECIFIED OTHERWISE)
- ALL 50 Hz CONNECTIONS ARE BSPT (UNLESS SPECIFIED OTHERWISE)

CUSTOMER CONNECTION		
ITEM	DESCRIPTION	COMMENTS
A	PACKAGE AIR INLET (COMPRESSOR)	
B	PACKAGE AIR EXHAUST (COMPRESSOR)	
C	PACKAGE AIR INLET (DRYER)	
D	PACKAGE AIR EXHAUST (DRYER)	
E	CONDENSATE DRAIN (MOISTURE SEPARATOR)	.25 INCH NPT (FEMALE)
F	CONDENSATE DRAIN (FILTER)	.25 INCH NPT (FEMALE)
G	CONDENSATE DRAIN (DRYER)	.25 INCH NPT (FEMALE)
H	ELECTRICAL INLET	BLANK PLATE SUPPLIED
J	DISCHARGE AIR	1.5 INCH (FEMALE)

GENERAL ARRANGEMENT TOLERANCES ALL DIMENSIONS ARE IN MILLIMETERS [INCHES (IF SHOWN)] UNSPECIFIED TOLERANCES: WHOLE : ±13.0[.50] X : ±6.0[.25] ANGLES : ±1° <small>Ingersoll-Rand Industrial Technologies</small>	<small>WARNING: THE EXPORT OR REEXPORT OF THIS DRAWING OR A PRODUCT PRODUCED BY THIS DRAWING IS SUBJECT TO U.S. EXPORT ADMINISTRATION REGULATIONS AND OTHER APPLICABLE GOVERNMENT RESTRICTIONS OR REGULATIONS.</small> PROPRIETARY NOTICE THIS DRAWING CONTAINS CONFIDENTIAL AND TRADE SECRET INFORMATION, IS THE PROPERTY OF INGERSOLL-RAND CO., AND IS GIVEN TO THE RECEIVER IN CONFIDENCE. THE RECEIVER BY RECEPTION AND RETENTION OF THE DRAWING ACCEPTS THE DRAWING IN CONFIDENCE AND AGREES THAT, EXCEPT AS AUTHORIZED IN WRITING BY INGERSOLL-RAND CO. IT WILL (1) NOT USE THE DRAWING OR ANY COPY THEREOF OR THE CONFIDENTIAL OR TRADE SECRET INFORMATION THEREIN; (2) NOT COPY THE DRAWING; (3) NOT DISCLOSE TO OTHERS EITHER THE DRAWING OR THE CONFIDENTIAL OR TRADE SECRET INFORMATION THEREIN; AND (4) UPON COMPLETION OF THE NEED TO RETAIN THE DRAWING, OR UPON DEMAND, RETURN THE DRAWING, ALL COPIES THEREOF, AND ALL MATERIAL COPIED THEREFROM.	DO NOT SCALE DRAWING DRAWING CONFORMS TO ASME Y14.5M - 1994 CAD GENERATED DRAWING, NO MANUAL REVISIONS ALLOWED UNLESS OTHERWISE SPECIFIED: - REMOVE ALL BURRS AND SHARP CORNERS - WELD SYMBOLS TO BE IN ACCORDANCE WITH ANSI/AWS A2.4 COPYRIGHT © 2017 Ingersoll Rand ALL RIGHTS RESERVED	 THIRD ANGLE PROJECTION DRAWN: J.WANG CHECKED: E.LIU APPROVED: WJ.ZHU DATE: 2015AUG21 DATE: 2015AUG21 DATE: 2015AUG21 DRAWING TYPE: General Arrangement Drawing NOMENCLATURE:	 GENERAL ARRANGEMENT, RS30-37i,n NAME:	SIZE: A1 SCALE: 0.20 ESTIMATED WEIGHT (KG UNLESS OTHERWISE SPECIFIED): SEE NOTES DWG NO.: 49182587 PART NO.: RS30-37i,n REVISION: C SHEET: 1 of 9
		<small>Ingersoll-Rand Industrial Technologies</small>			

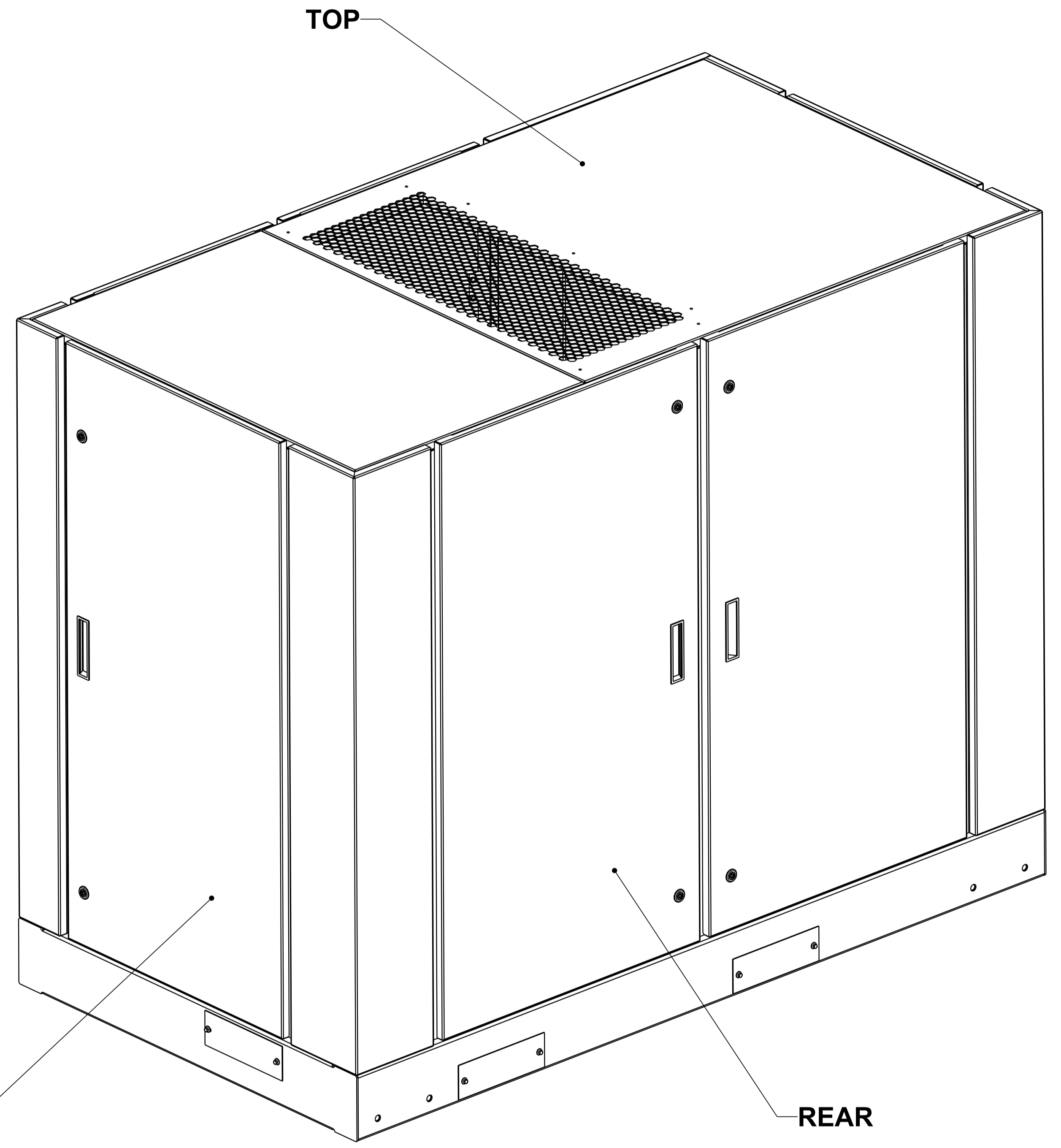
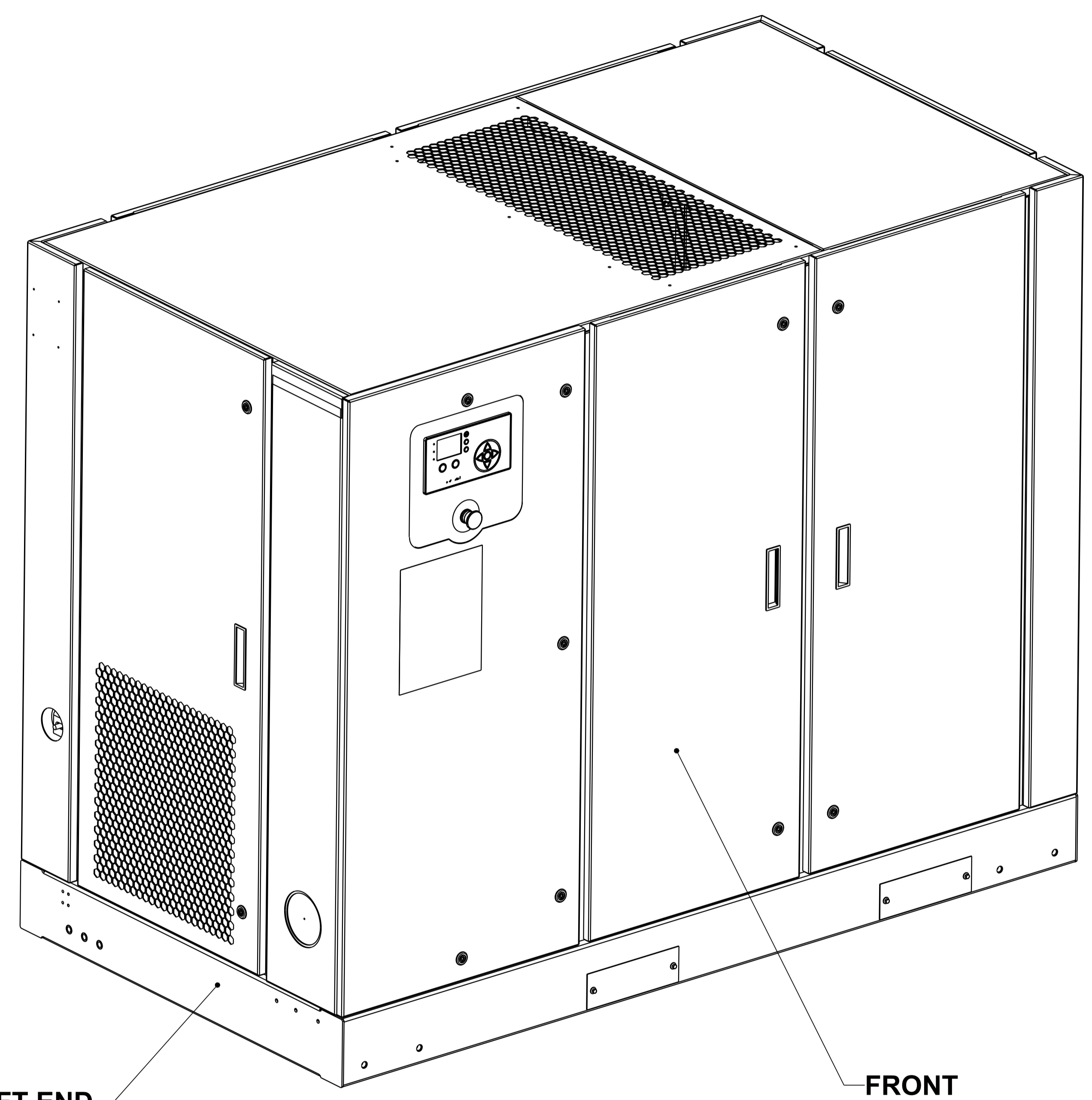

PROPRIETARY NOTICE
 THIS DRAWING CONTAINS CONFIDENTIAL AND TRADE SECRET INFORMATION. IS THE PROPERTY OF INGERSOLL-RAND CO. AND IS GIVEN TO THE RECEIVER IN CONFIDENCE. THE RECEIVER BY RECEIPT AND RETENTION OF THE DRAWING ACCEPTS THE DRAWING IN CONFIDENCE AND AGREES THAT, EXCEPT AS AUTHORIZED IN WRITING BY INGERSOLL-RAND CO., IT WILL (1) NOT USE THE DRAWING OR ANY COPY THEREOF OR THE CONFIDENTIAL OR TRADE SECRET INFORMATION THEREIN, (2) NOT COPY THE DRAWING, (3) NOT DISCLOSE TO OTHERS EITHER THE DRAWING OR THE CONFIDENTIAL OR TRADE SECRET INFORMATION THEREIN, AND (4) UPON COMPLETION OF THE NEED TO RETAIN THE DRAWING, OR UPON DEMAND, RETURN THE DRAWING, ALL COPIES THEREOF, AND ALL MATERIAL COPIED THEREFROM.

NAME	GENERAL ARRANGEMENT, RS30-37i,n			
SIZE	DWG NO.	PART NO.	REVISION	
A1		49182587	C	
SCALE	0.20 NOMENCLATURE		SHEET 2 of 9	

OPTION: NON - TAS

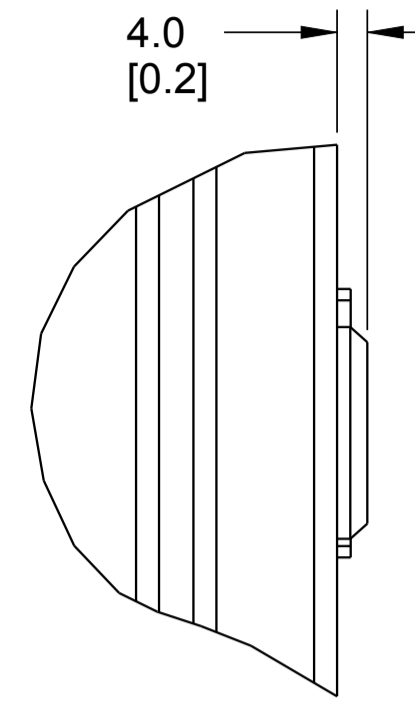

DETAIL A
SCALE 1.000

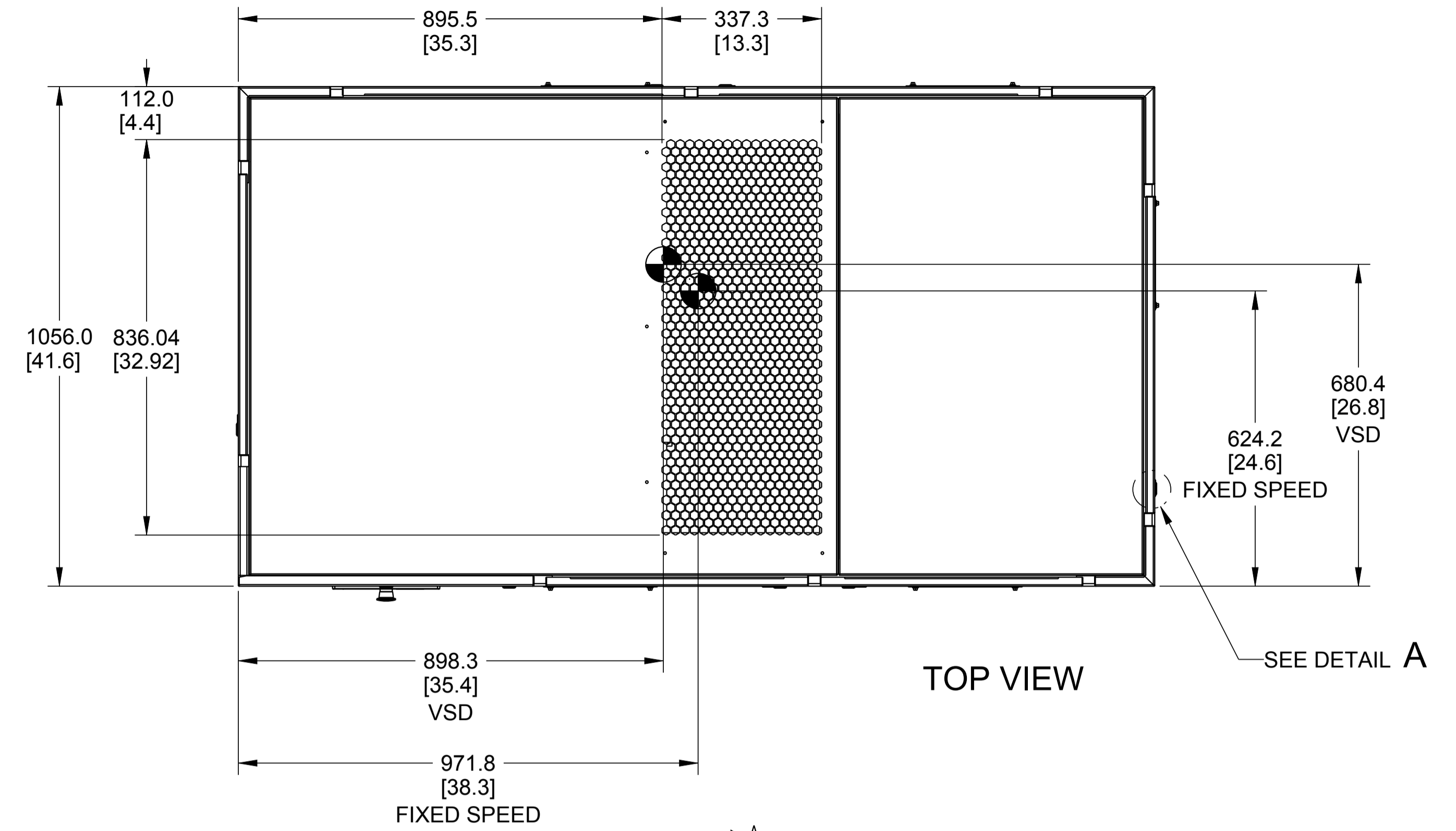

TOP VIEW

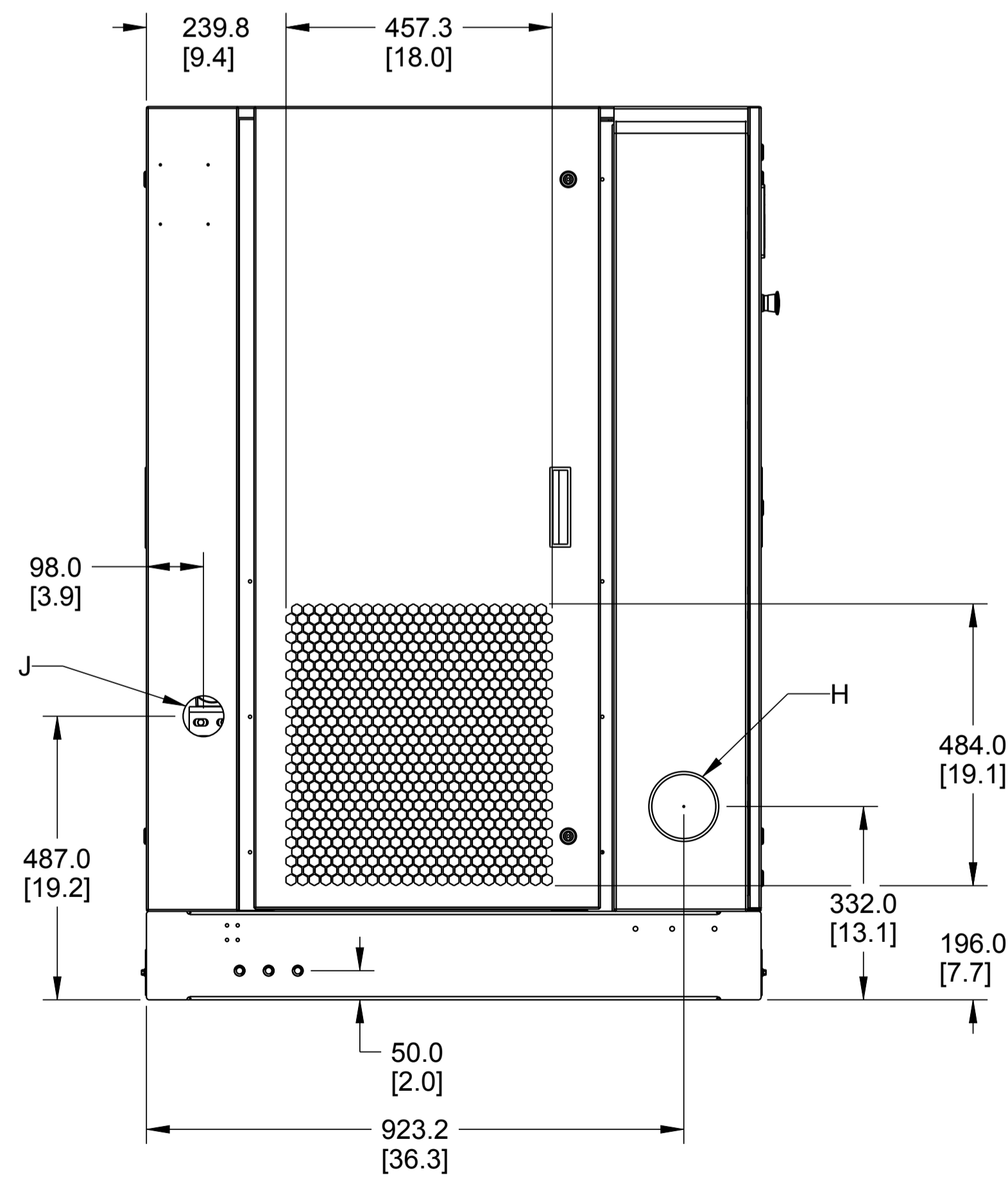

LEFT END VIEW

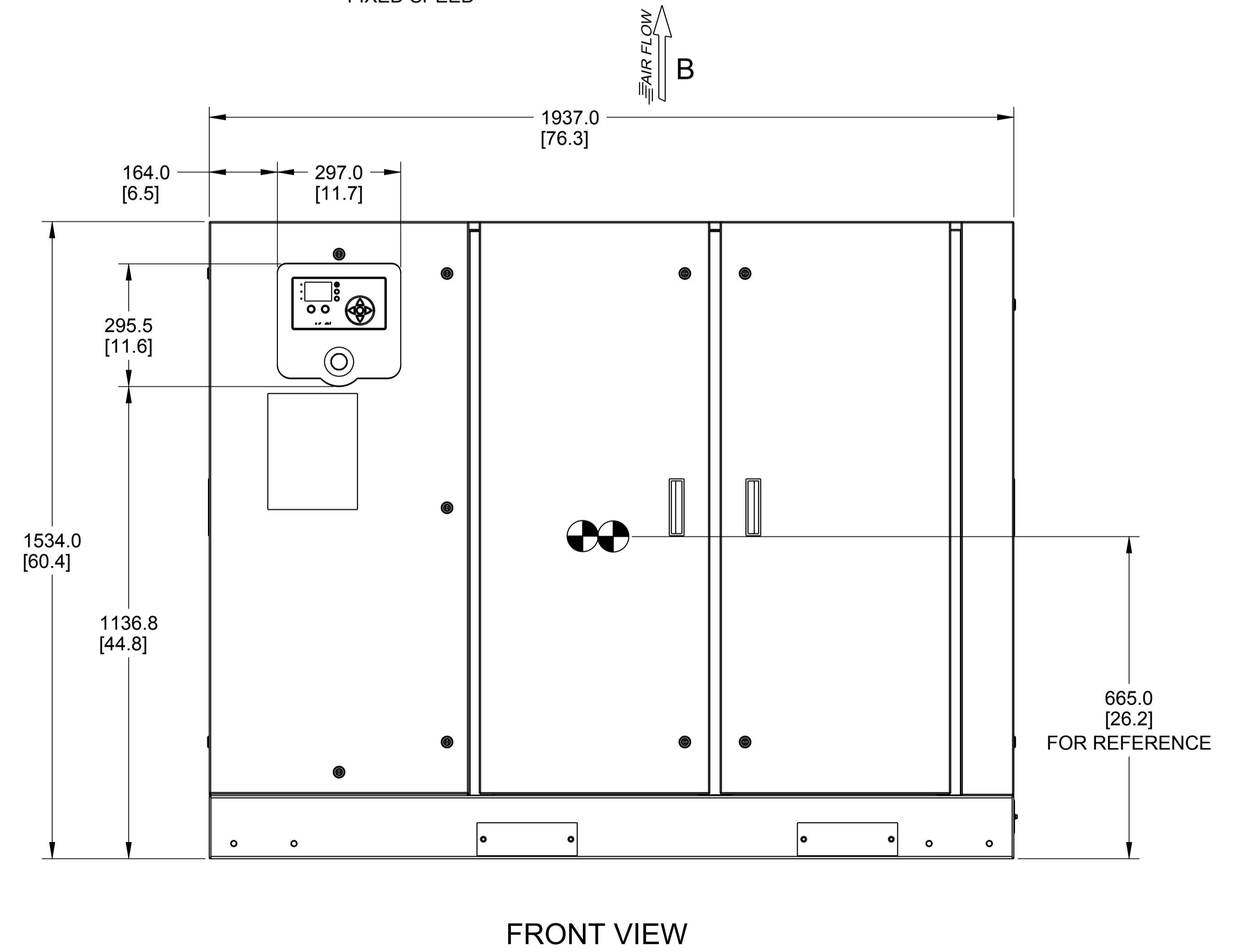

FRONT VIEW

<small>PROPRIETARY NOTICE</small> THIS DRAWING CONTAINS CONFIDENTIAL AND TRADE SECRET INFORMATION IS THE PROPERTY OF INgersoll-RAND CO. AND IS GIVEN TO THE RECEIVER IN CONFIDENCE. THE RECEIVER BY RECEIPT AND RETENTION OF THIS DRAWING ACCEPTS THE DRAWING IN CONFIDENCE AND AGREES THAT, EXCEPT AS AUTHORIZED IN WRITING BY INgersoll-RAND CO. IT WILL (1) NOT USE THE DRAWING OR ANY COPY THEREOF OR THE CONFIDENTIAL OR TRADE SECRET INFORMATION THEREIN; (2) NOT COPY THE DRAWING; (3) NOT DISCLOSE TO OTHERS EITHER THE DRAWING OR THE CONFIDENTIAL OR TRADE SECRET INFORMATION THEREIN; AND (4) UPON COMPLETION OF THE NEED TO RETAIN THE DRAWING OR UPON DEMAND, RETURN THE DRAWING, ALL COPIES THEREOF, AND ALL MATERIAL COPIED THEREFROM.		NAME GENERAL ARRANGEMENT, RS30-37i,n	
SIZE A1	DWG NO. 49182587	REVISION C	
SCALE 0.20	NOMENCLATURE	SHEET 3 OF 9	

OPTION: WITH - TAS

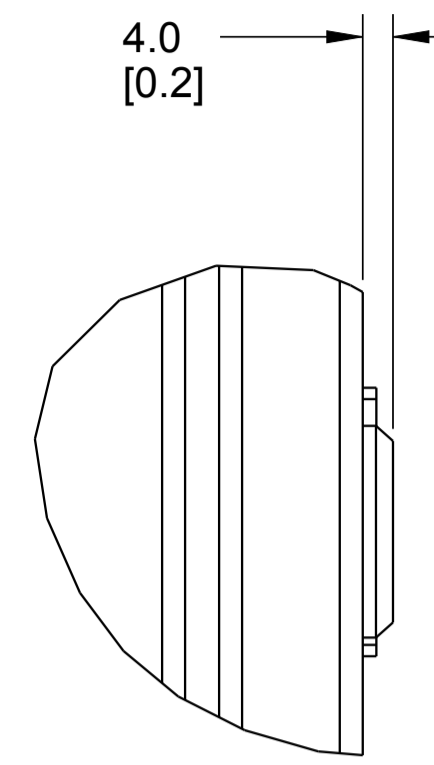

DETAIL B
SCALE 1.000

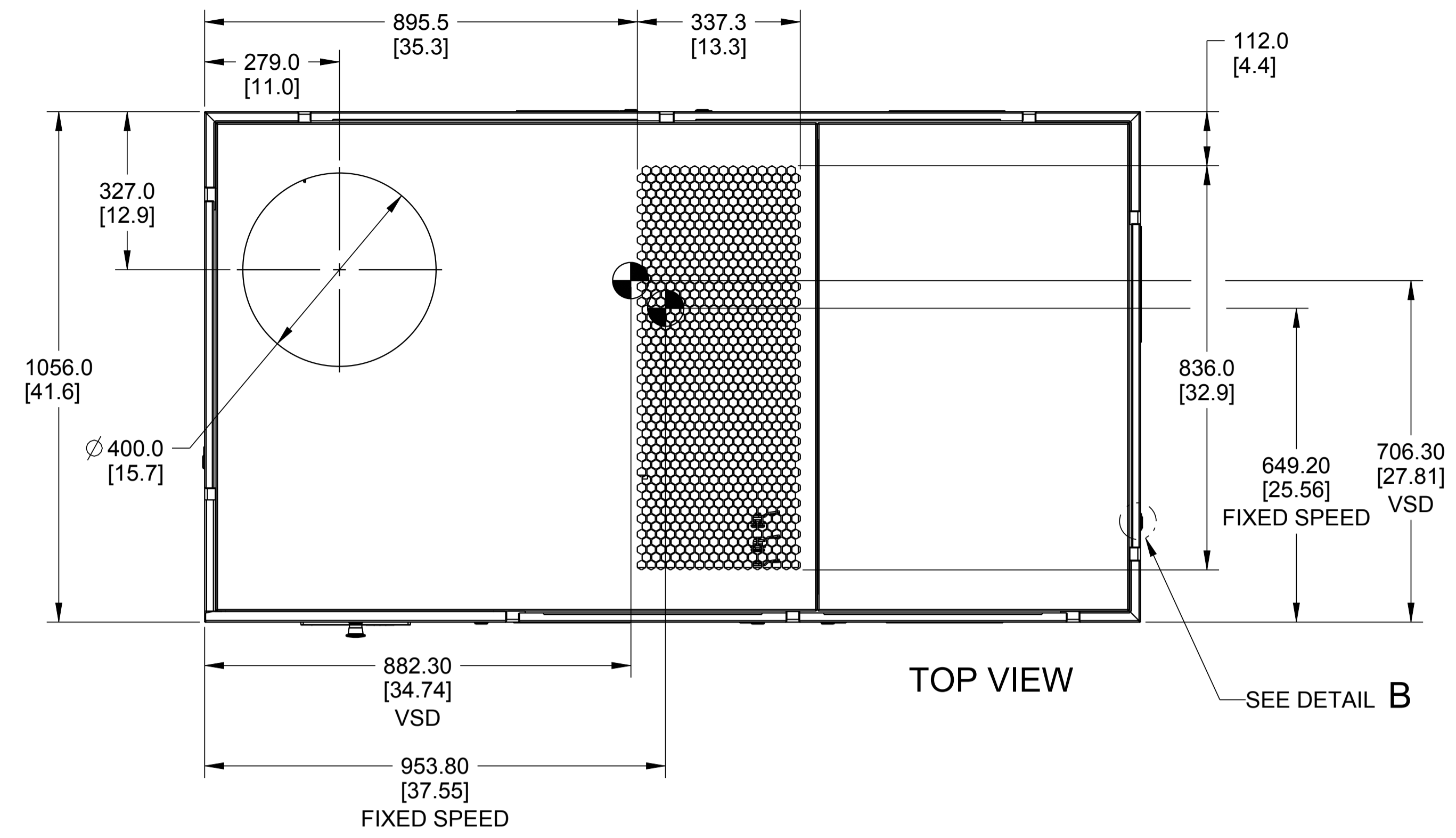

TOP VIEW
SEE DETAIL B

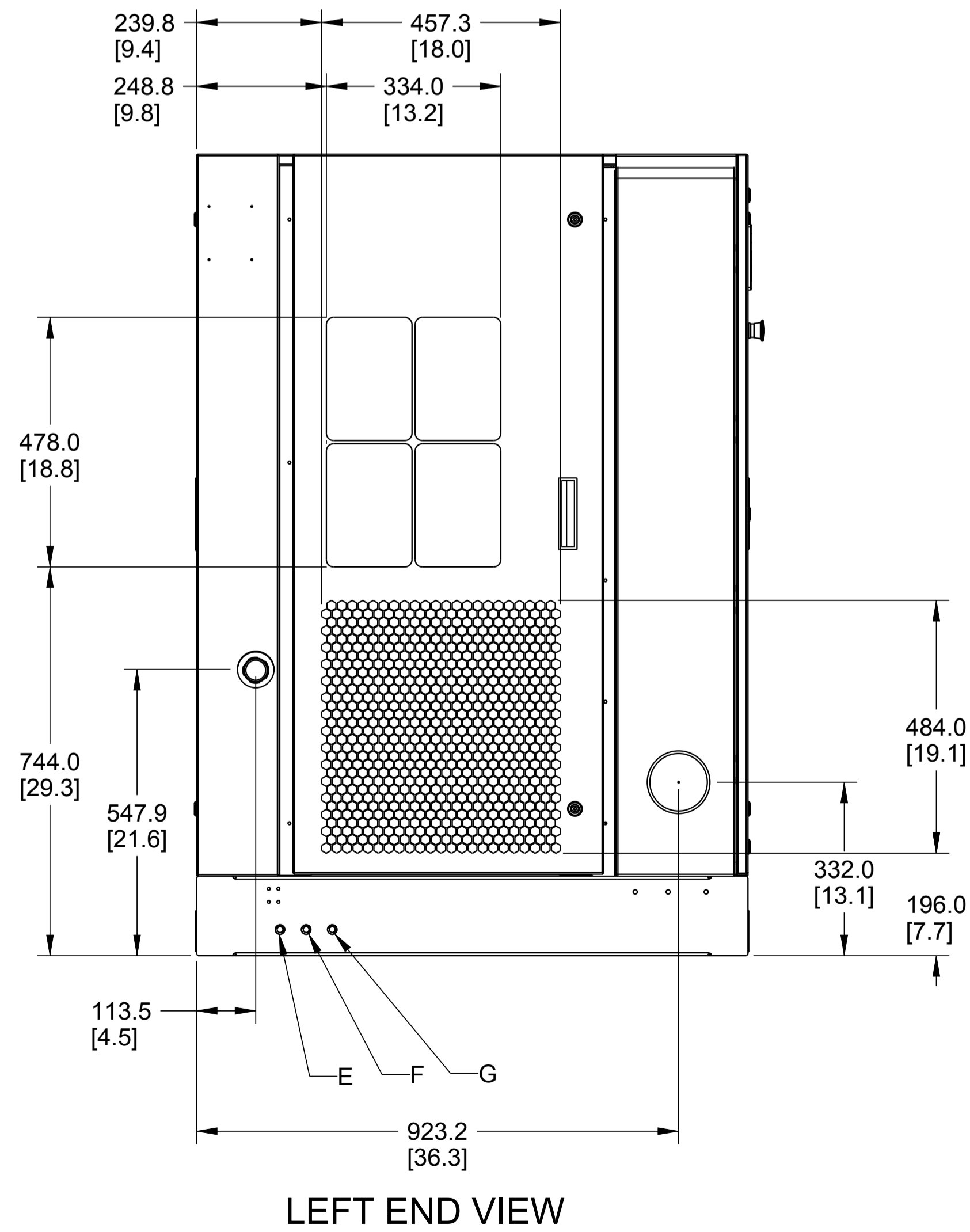

LEFT END VIEW

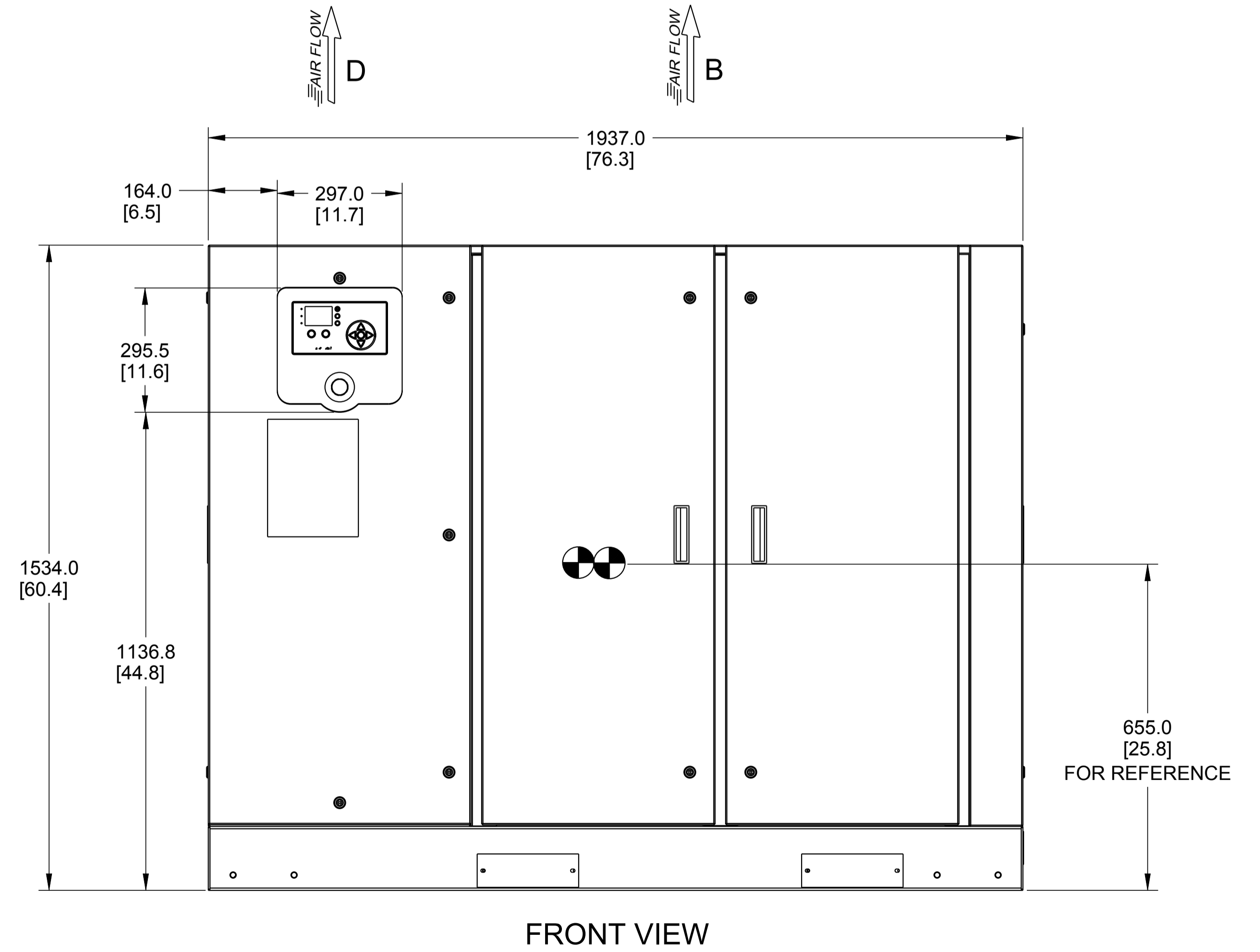

FRONT VIEW

<small>PROPRIETARY NOTICE</small> <small>THIS DRAWING CONTAINS CONFIDENTIAL AND TRADE SECRET INFORMATION. IS THE PROPERTY OF INGERSOLL-RAND CO. AND IS GIVEN TO THE RECEIVER IN CONFIDENCE. THE RECEIVER BY ACCEPTANCE AND RETENTION OF THIS DRAWING ACCEPTS THE DRAWING IN CONFIDENCE AND AGREES THAT, EXCEPT AS AUTHORIZED IN WRITING BY INGERSOLL-RAND CO., IT WILL (1) NOT USE THE DRAWING OR ANY COPY THEREOF OR THE CONFIDENTIAL OR TRADE SECRET INFORMATION THEREIN; (2) NOT COPY THE DRAWING; (3) NOT DISCLOSE TO OTHERS EITHER THE DRAWING OR THE CONFIDENTIAL OR TRADE SECRET INFORMATION THEREIN; AND (4) UPON COMPLETION OF THE NEED TO RETAIN THE DRAWING, OR UPON DEMAND, RETURN THE DRAWING, ALL COPIES THEREOF, AND ALL MATERIAL COPIED THEREFROM.</small>		<small>NAME</small> GENERAL ARRANGEMENT, RS30-37i,n	
<small>SIZE</small> A1	<small>DWG NO.</small> 49182587	<small>REVISION</small> C	
<small>SCALE</small> 0.20	<small>NOMENCLATURE</small>	<small>SHEET</small> 4	<small>OF 9</small>

8 7 6 5 4 3 2 1

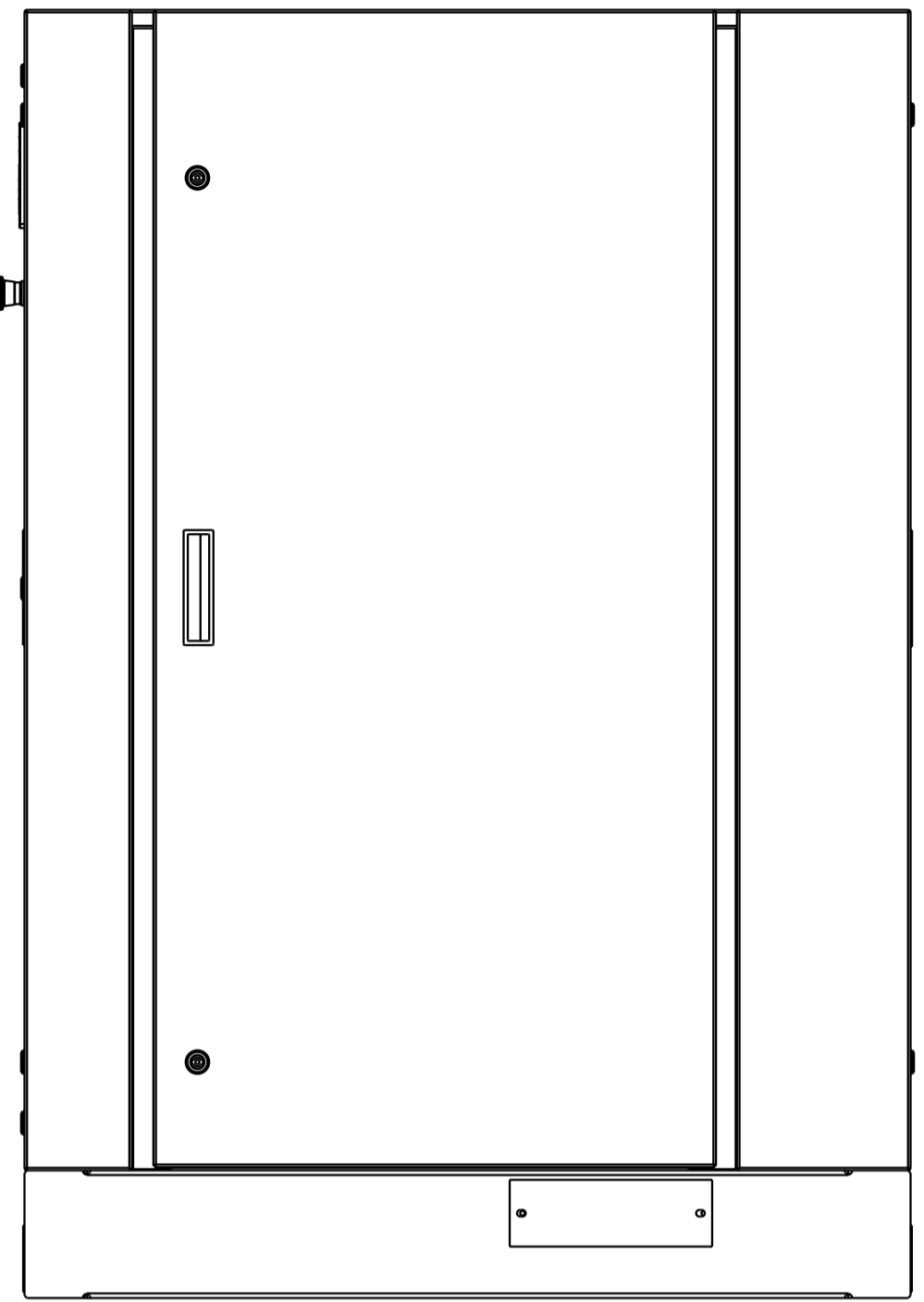

RIGHT END VIEW

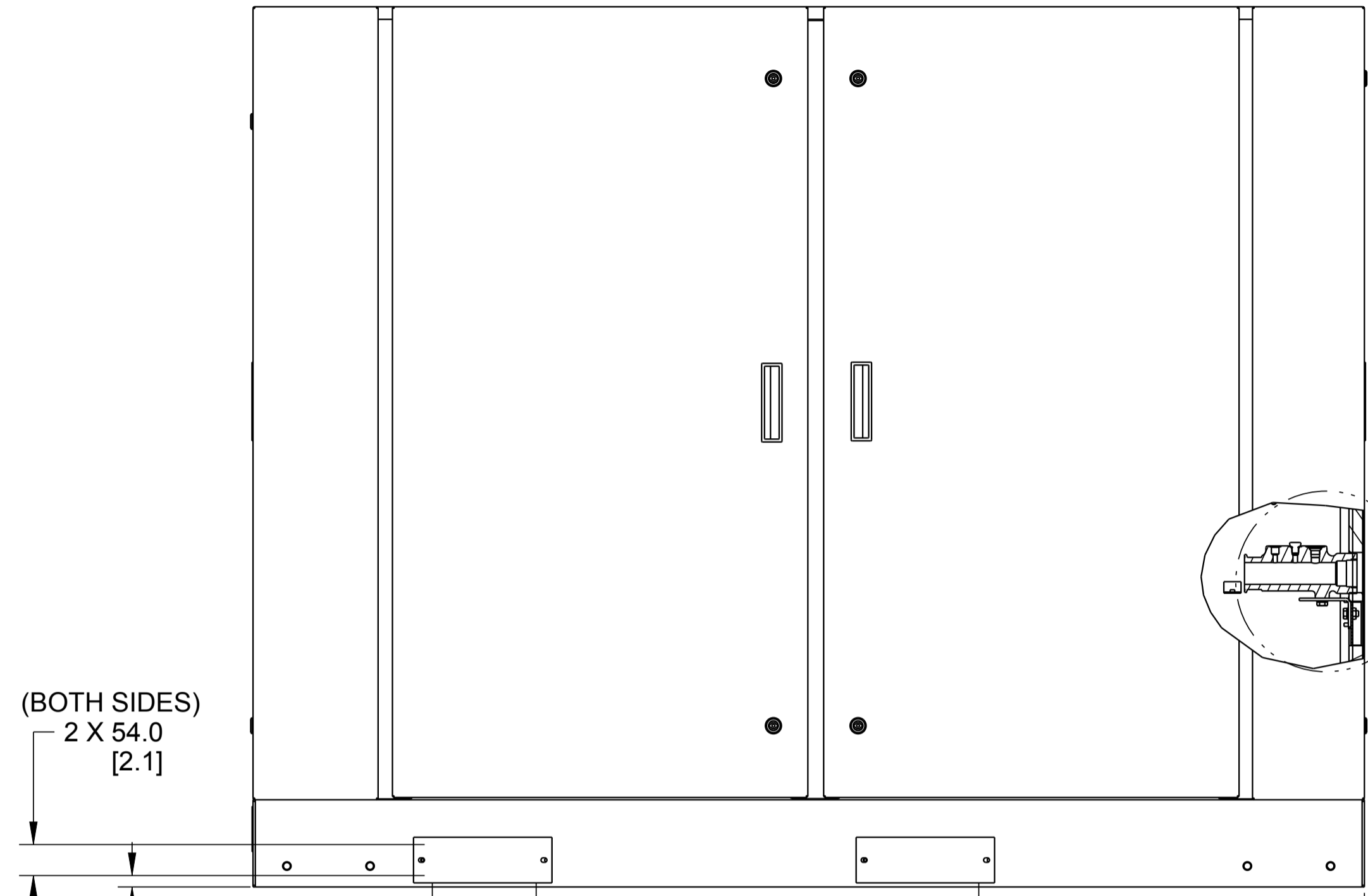

SECTION A-A
REAR VIEW

(BOTH SIDES)
2 X 54.0
[2.1]

2 X 19.9
[0.8]
(BOTH SIDES)

4 X 181.0
[7.1]
(BOTH SIDES)

2 X 771.4
[30.4]
(BOTH SIDES)

2 X 672.1
[26.5]
(BOTH SIDES)

SEE DETAIL C

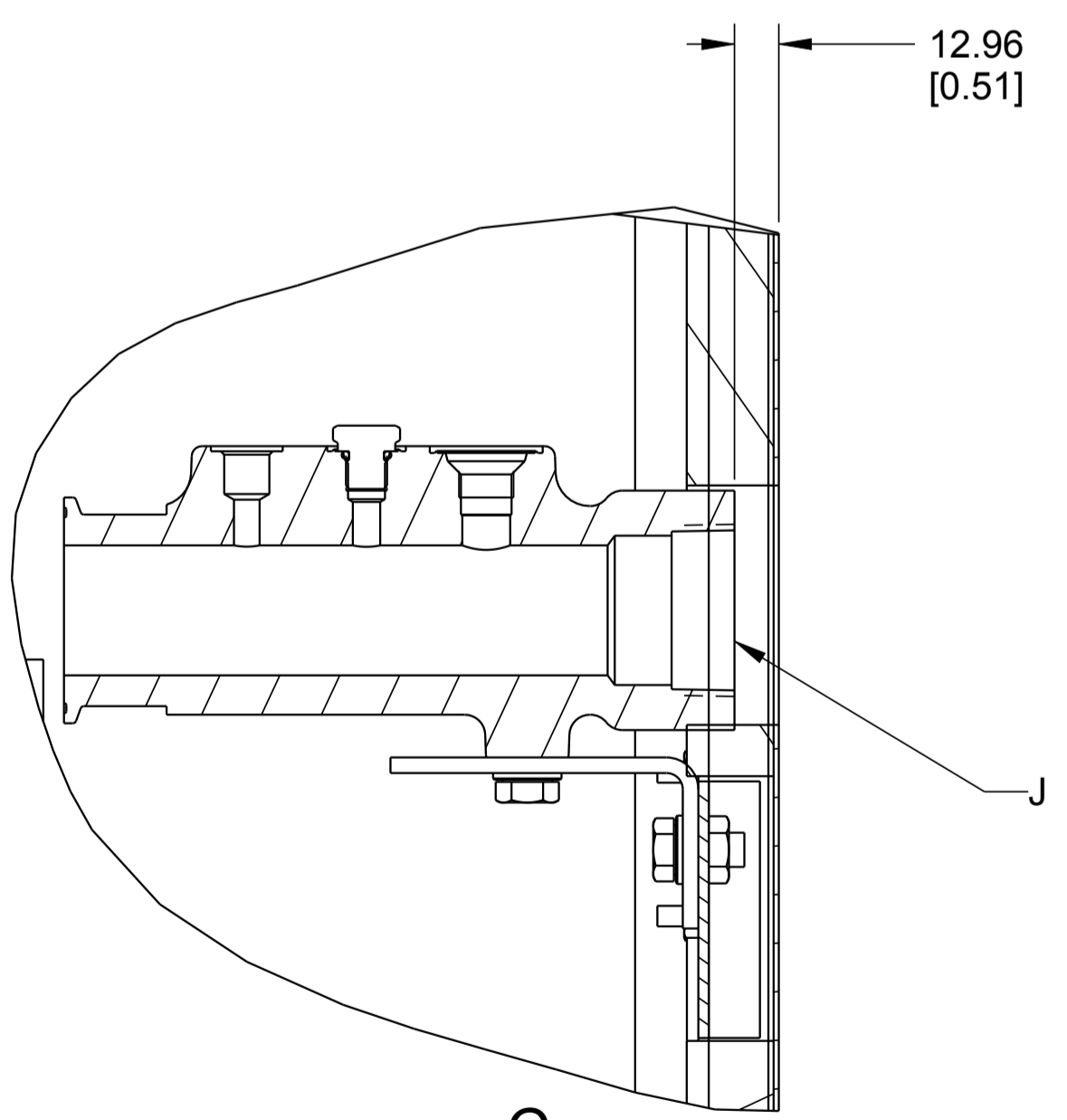

DETAIL C
SCALE 0.500

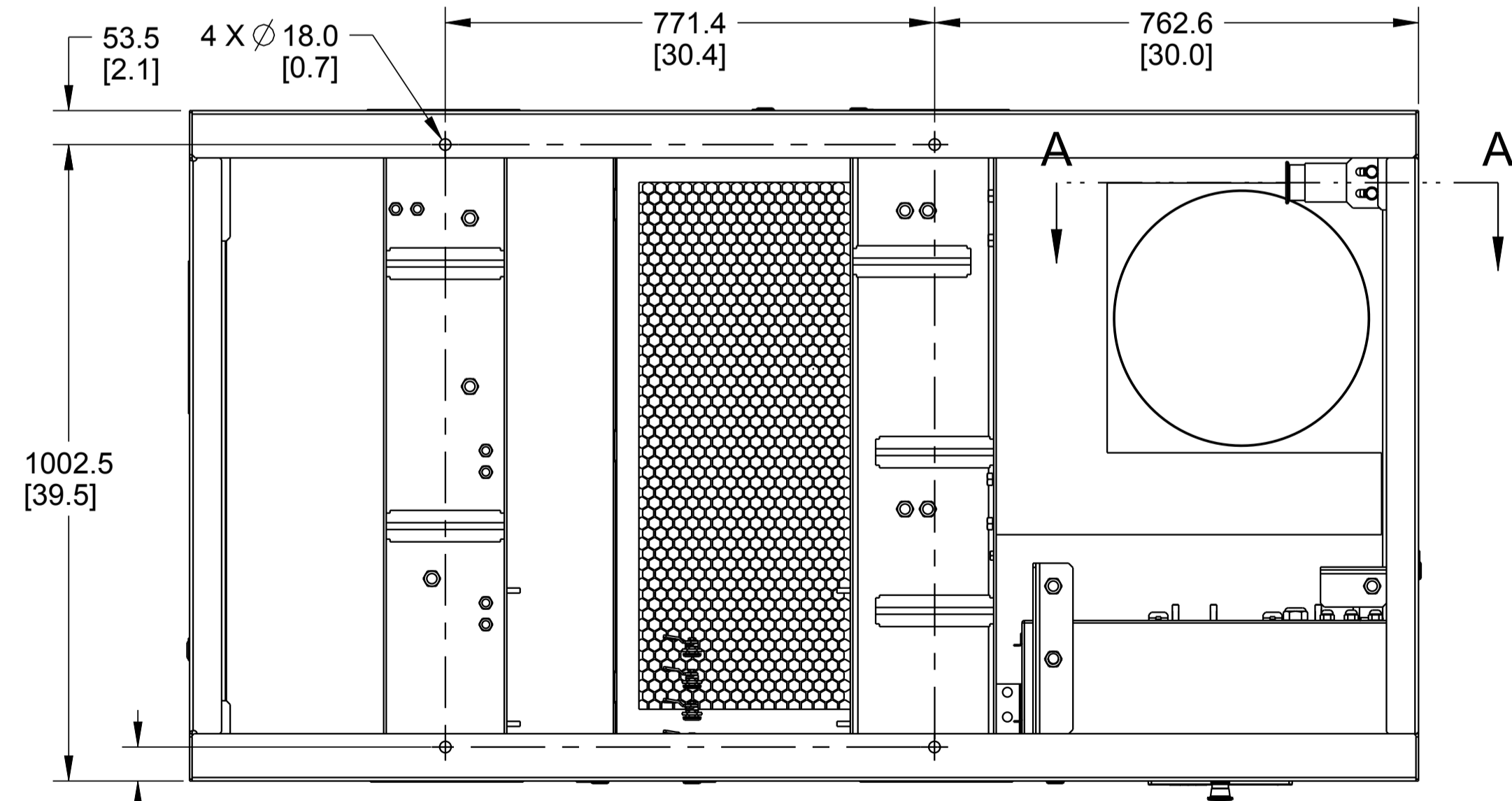

BOTTOM VIEW

53.5
[2.1]

4 X Ø 18.0
[0.7]

771.4
[30.4]

762.6
[30.0]

1002.5
[39.5]

53.5
[2.1]

<small>PROPRIETARY NOTICE</small> <small>THIS DRAWING CONTAINS CONFIDENTIAL AND TRADE SECRET INFORMATION. IS THE PROPERTY OF INGERSOLL-RAND CO. AND IS GIVEN TO THE RECEIVER IN CONFIDENCE. THE RECEIVER BY RECEIPT AND RETENTION OF THE DRAWING ACCEPTS THE DRAWING IN CONFIDENCE AND AGREES THAT, EXCEPT AS AUTHORIZED IN WRITING BY INGERSOLL-RAND CO., IT WILL (1) NOT USE THE DRAWING OR ANY COPY THEREOF OR THE CONFIDENTIAL OR TRADE SECRET INFORMATION THEREIN, (2) NOT COPY THE DRAWING, (3) NOT DISCLOSE TO OTHERS EITHER THE DRAWING OR THE CONFIDENTIAL OR TRADE SECRET INFORMATION THEREIN, AND (4) UPON COMPLETION OF THE NEED TO RETAIN THE DRAWING, OR UPON DEMAND, RETURN THE DRAWING, ALL COPIES THEREOF, AND ALL MATERIAL COPIED THEREFROM.</small>		<small>NAME</small> GENERAL ARRANGEMENT, RS30-37i,n	
<small>SIZE</small> A1	<small>DWG NO.</small> 49182587	<small>REVISION</small> C	
<small>SCALE</small> 0.20	<small>NOMENCLATURE</small>	<small>SHEET</small> 5 OF 9	

8 7 6 5 4 3 2 1

GENERAL ARRANGEMENT WITH
OPTIONAL CONTAINMENT BASE

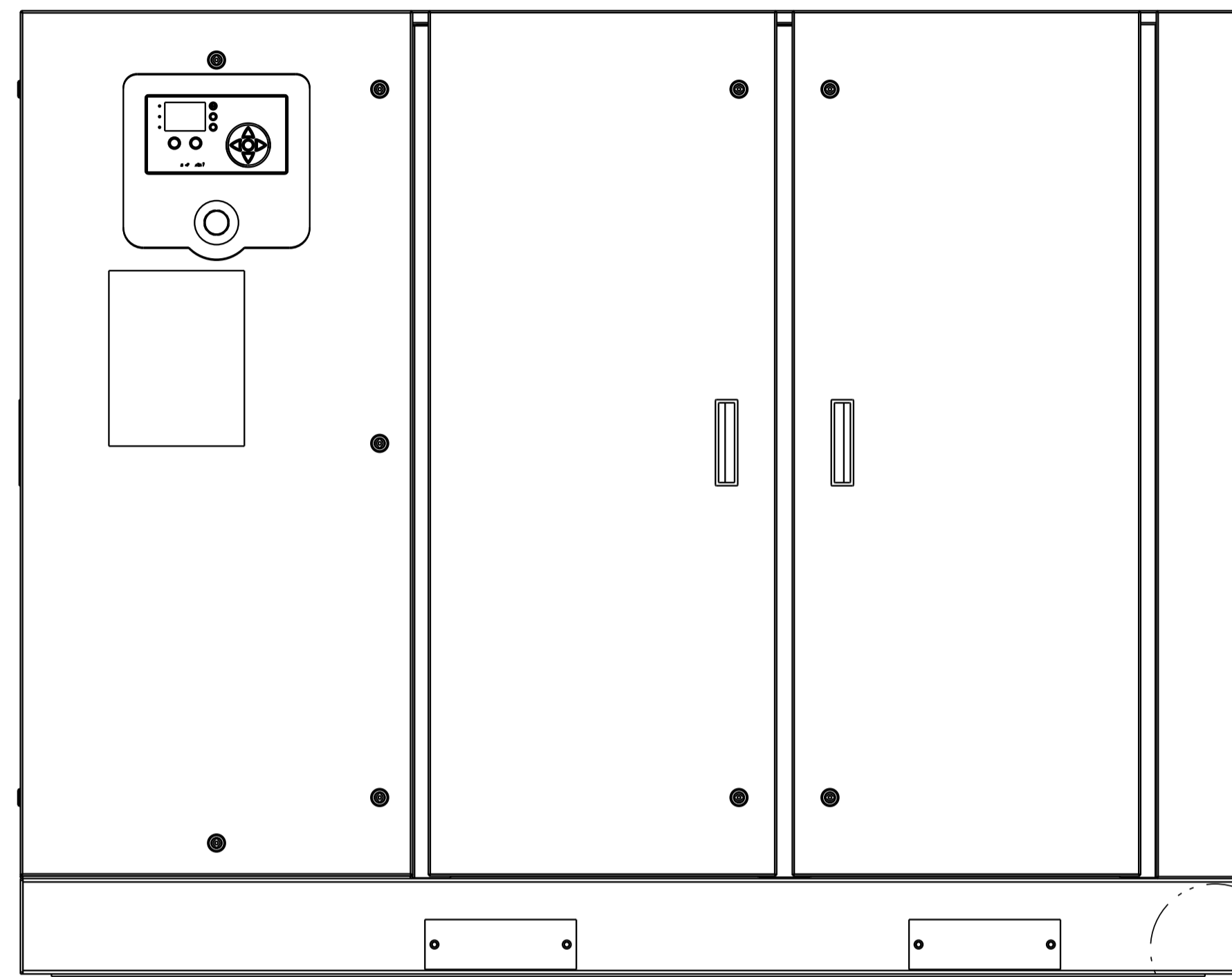

FRONT VIEW

SEE DETAIL D

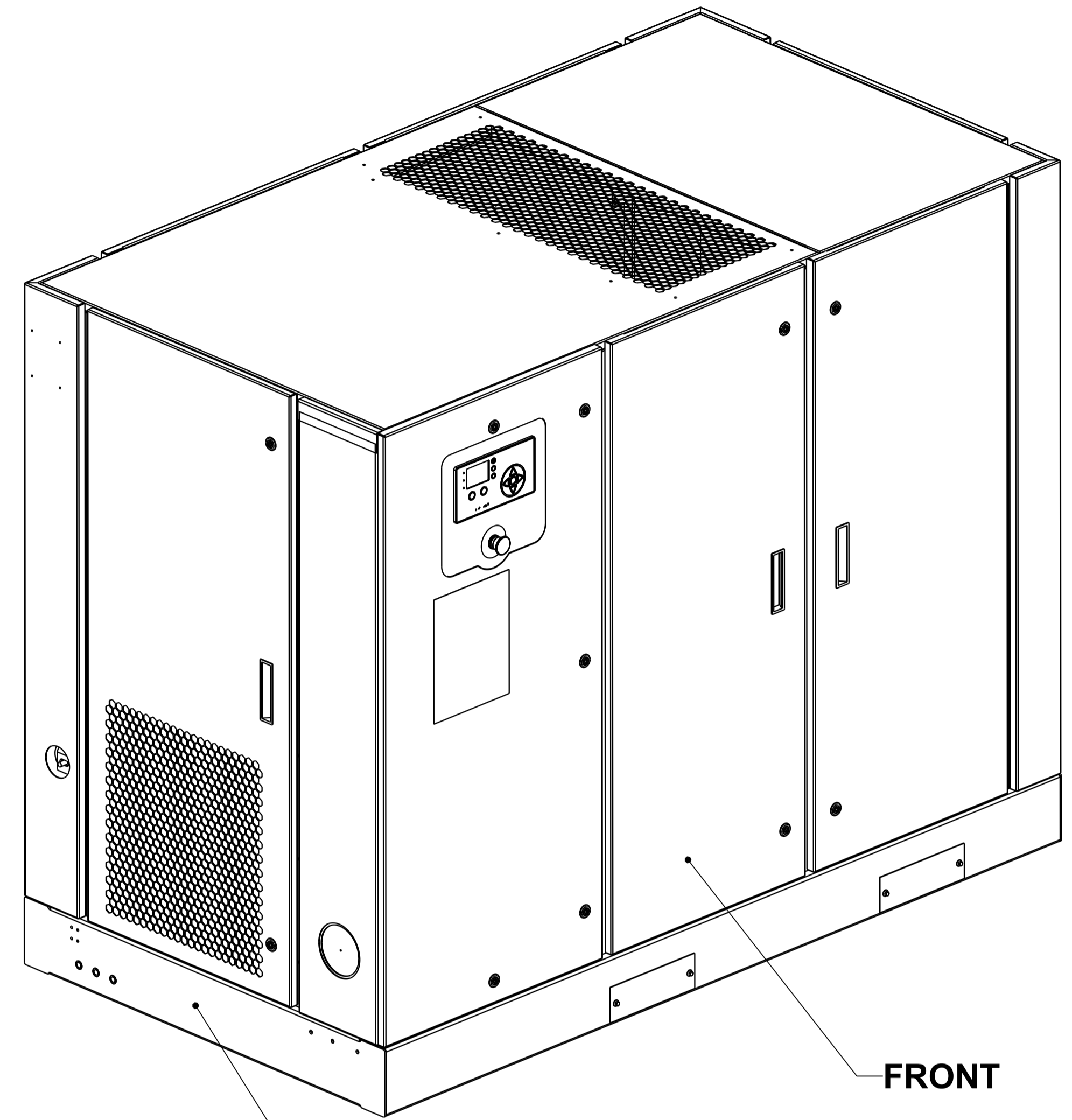

FRONT

LEFT END

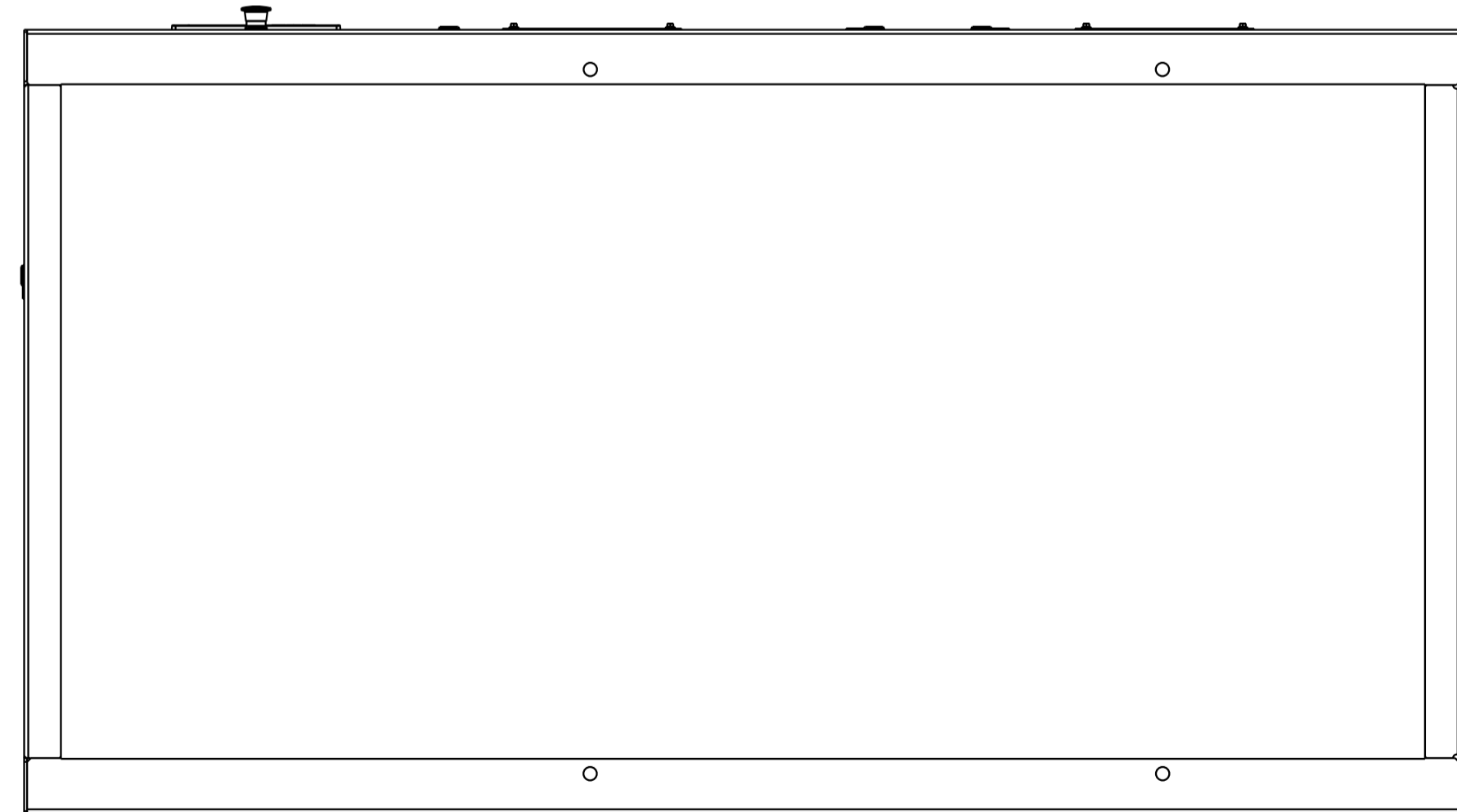

BOTTOM VIEW

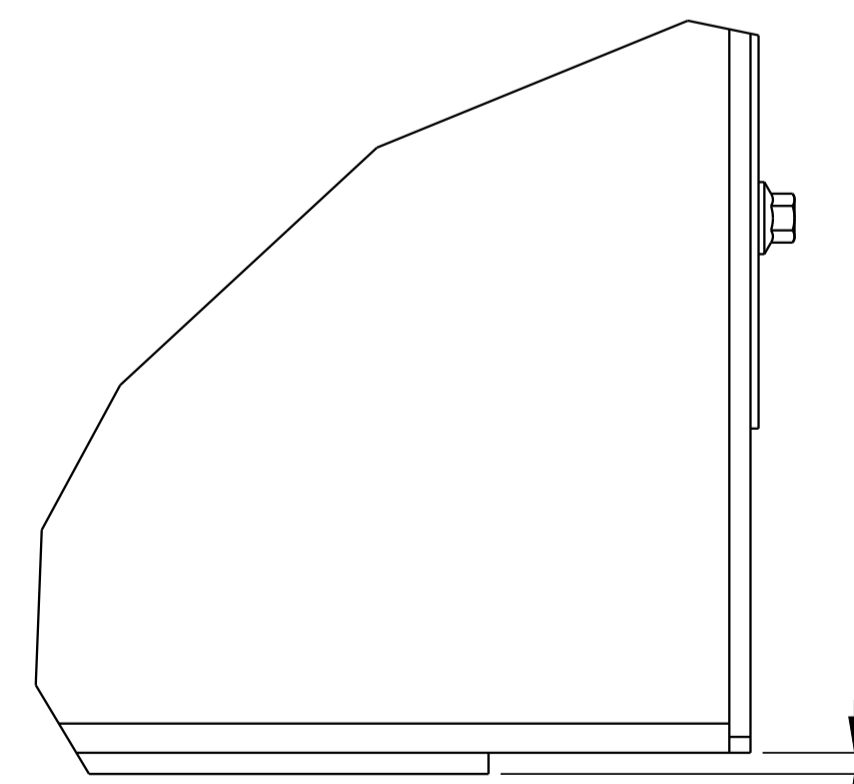

DETAIL D
SCALE 0.700

4.0
[0.2]
THIS VALUE NEEDS TO BE ADDED
TO ALL HEIGHT DIMENSIONS
WHEN THIS OPTION IS PURCHASED.

<small>PROPRIETARY NOTICE</small> <small>THIS DRAWING CONTAINS CONFIDENTIAL AND TRADE SECRET INFORMATION. IS THE PROPERTY OF INGERSOLL-RAND CO., AND IS GIVEN TO THE RECEIVER IN CONFIDENCE. THE RECEIVER BY RECEIPT AND RETENTION OF THE DRAWING ACCEPTS THE DRAWING IN CONFIDENCE AND AGREES THAT, EXCEPT AS AUTHORIZED IN WRITING BY INGERSOLL-RAND CO., IT WILL (1) NOT USE THE DRAWING OR ANY COPY THEREOF OR THE CONFIDENTIAL OR TRADE SECRET INFORMATION THEREIN; (2) NOT COPY THE DRAWING; (3) NOT DISCLOSE TO OTHERS EITHER THE DRAWING OR THE CONFIDENTIAL OR TRADE SECRET INFORMATION THEREIN; AND (4) UPON COMPLETION OF THE NEED TO RETAIN THE DRAWING OR UPON DEMAND, RETURN THE DRAWING, ALL COPIES THEREOF, AND ALL MATERIAL COPIED THEREFROM.</small>		<small>NAME</small> GENERAL ARRANGEMENT, RS30-37i,n	
<small>SIZE</small> A1	<small>DWG NO.</small> 49182587	<small>REVISION</small> C	
<small>SCALE</small> 0.20	<small>NOMENCLATURE</small>	<small>SHEET</small> 6 OF 9	

GENERAL ARRANGEMENT WITH
 OPTIONAL HIGH DUST PRE-FILTER - NO DRYER
 (OPTION IS NOT AVAILABLE FOR VSD UNITS)

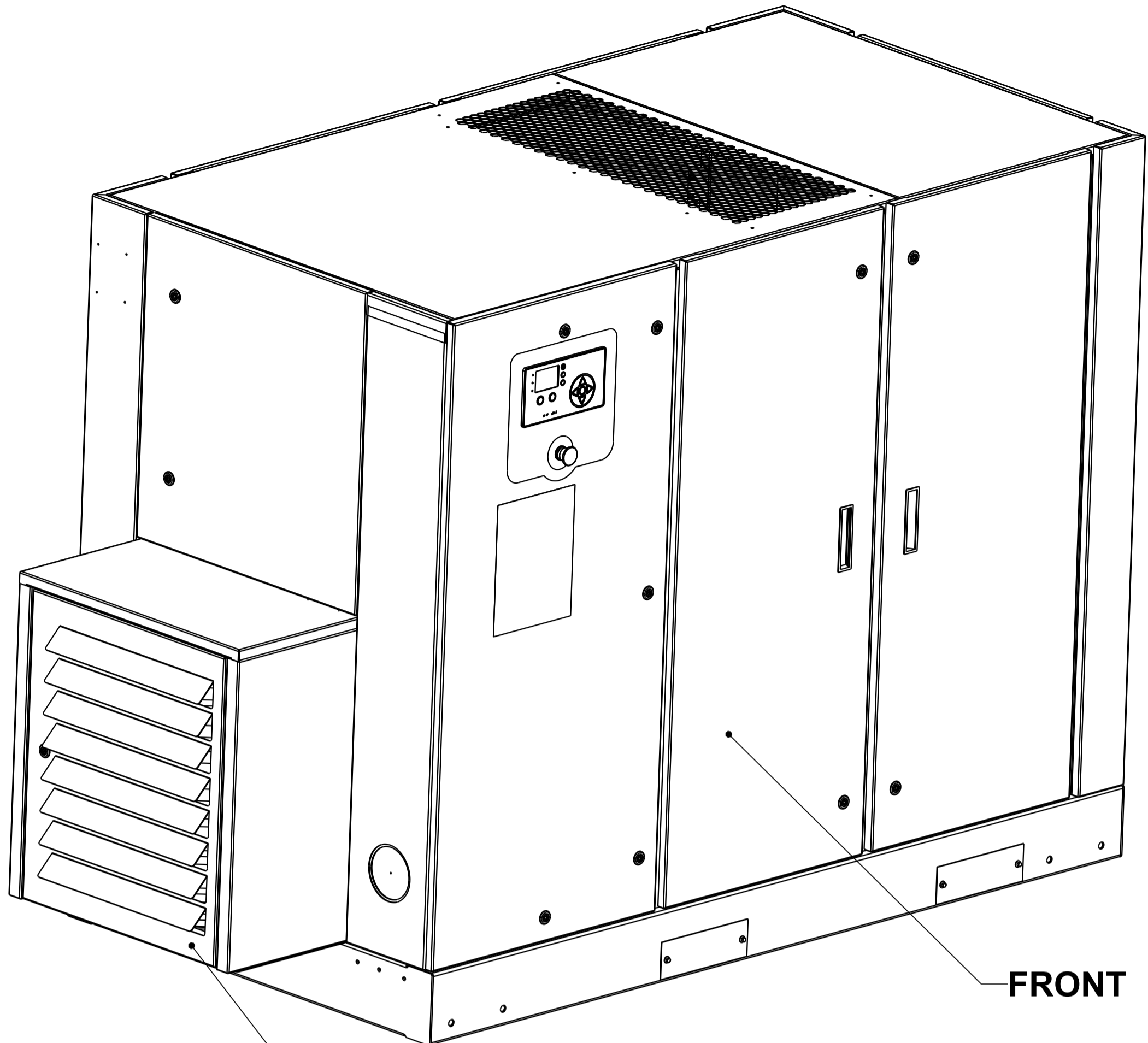

FRONT

LEFT END

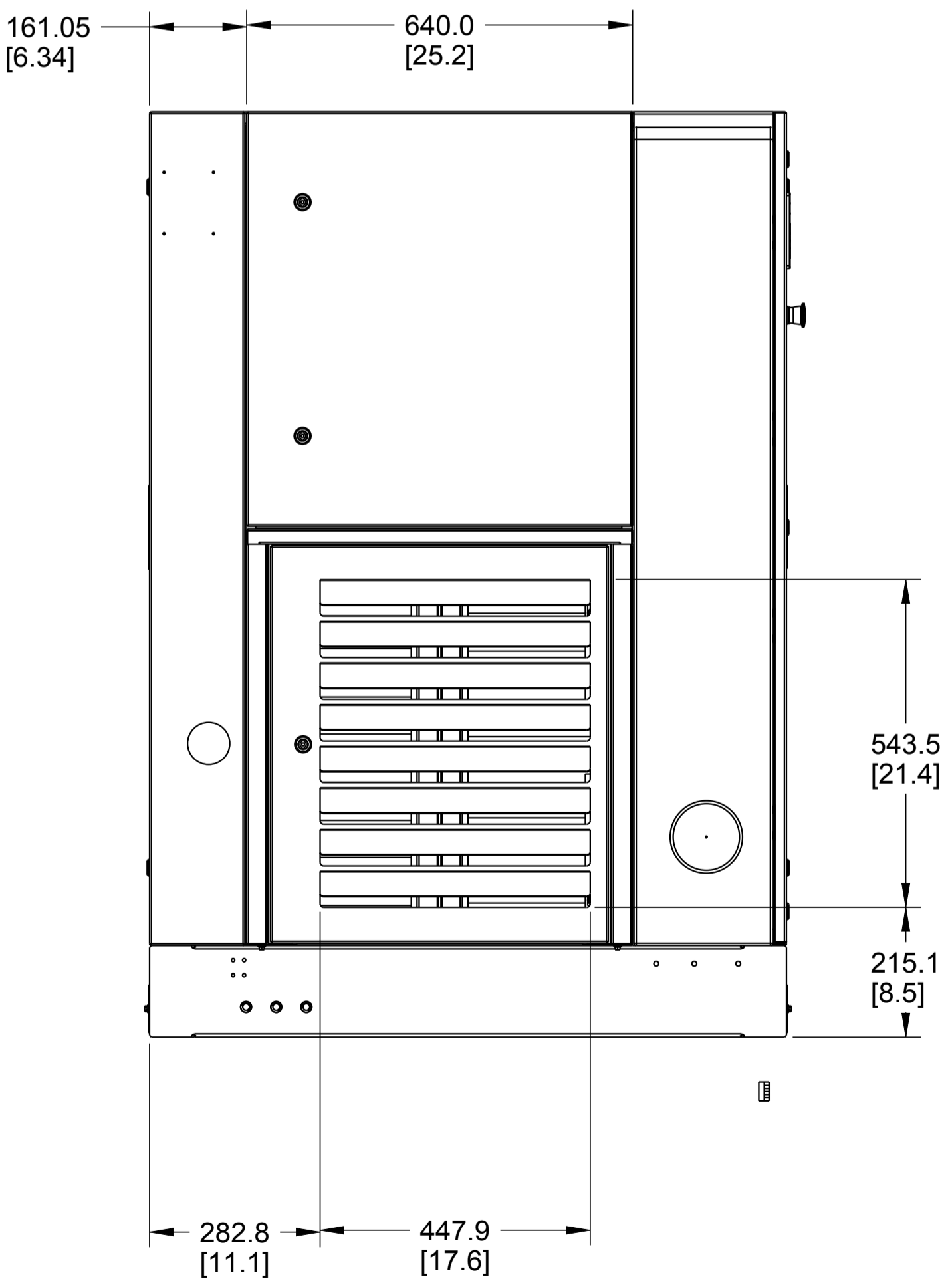

LEFT END VIEW

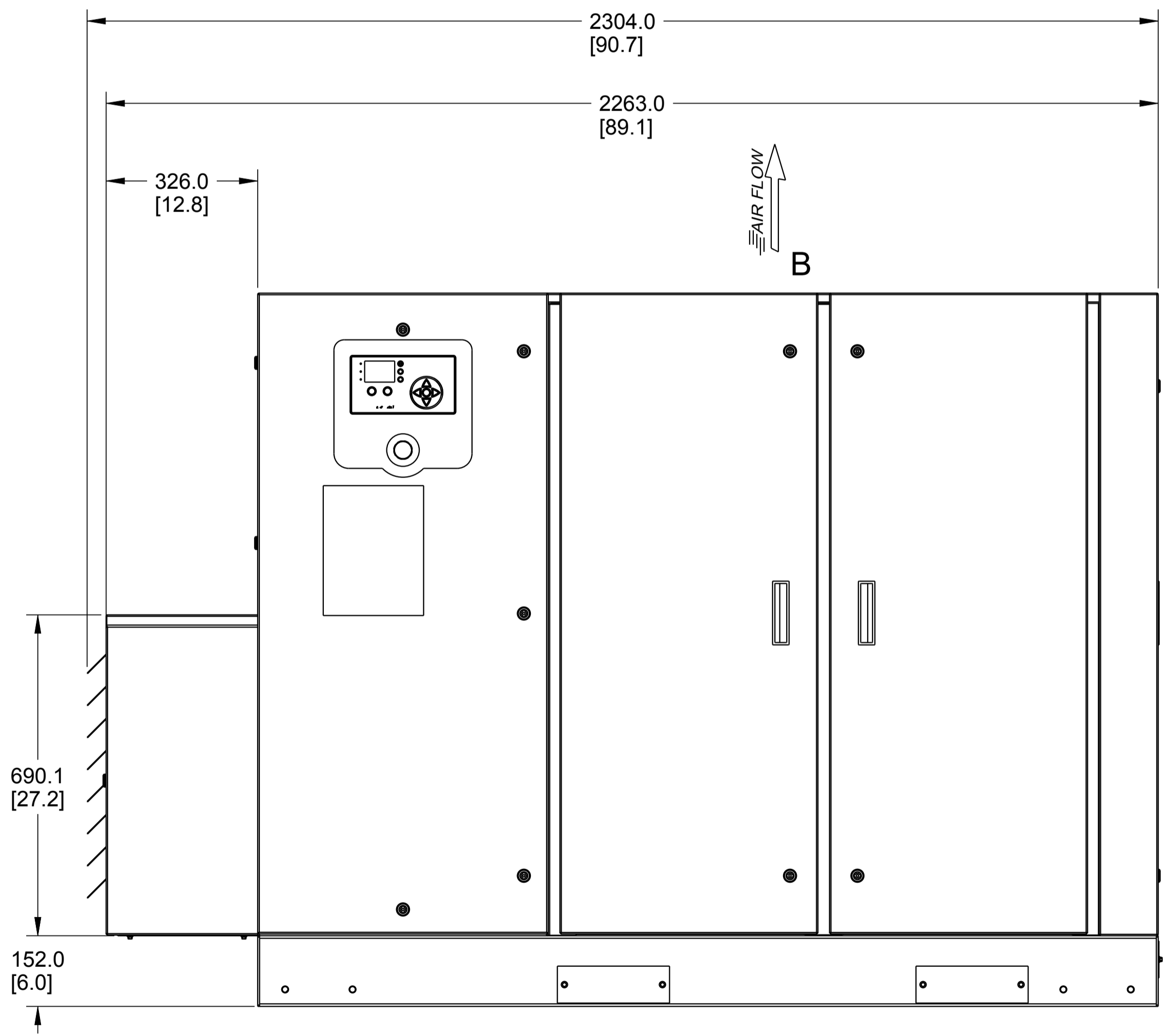
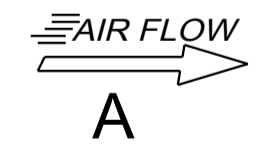

FRONT VIEW

<small>PROPRIETARY NOTICE</small> <small>THIS DRAWING CONTAINS CONFIDENTIAL AND TRADE SECRET INFORMATION. IS THE PROPERTY OF INGERSOLL-RAND CO. AND IS GIVEN TO THE RECEIVER IN CONFIDENCE. THE RECEIVER BY ACCEPTANCE AND RETENTION OF THE DRAWING ACCEPTS THE DRAWING IN CONFIDENCE AND AGREES THAT, EXCEPT AS AUTHORIZED IN WRITING BY INGERSOLL-RAND CO., IT WILL (1) NOT USE THE DRAWING OR ANY COPY THEREOF OR THE CONFIDENTIAL OR TRADE SECRET INFORMATION THEREIN, (2) NOT COPY THE DRAWING, (3) NOT DISCLOSE TO OTHERS EITHER THE DRAWING OR THE CONFIDENTIAL OR TRADE SECRET INFORMATION THEREIN, AND (4) UPON COMPLETION OF THE NEED TO RETAIN THE DRAWING, OR UPON DEMAND, RETURN THE DRAWING, ALL COPIES THEREOF, AND ALL MATERIAL COPIED THEREFROM.</small>		<small>NAME</small> GENERAL ARRANGEMENT, RS30-37i,n	
<small>SIZE</small> A1	<small>DWG NO.</small> 49182587	<small>REVISION</small> C	
<small>SCALE</small> 0.20	<small>NOMENCLATURE</small>	<small>SHEET</small> 7 of 9	

GENERAL ARRANGEMENT WITH
 OPTIONAL OUTDOOR MODIFICATION
 (OPTION IS NOT AVAILABLE FOR DRYER OR VSD UNITS)

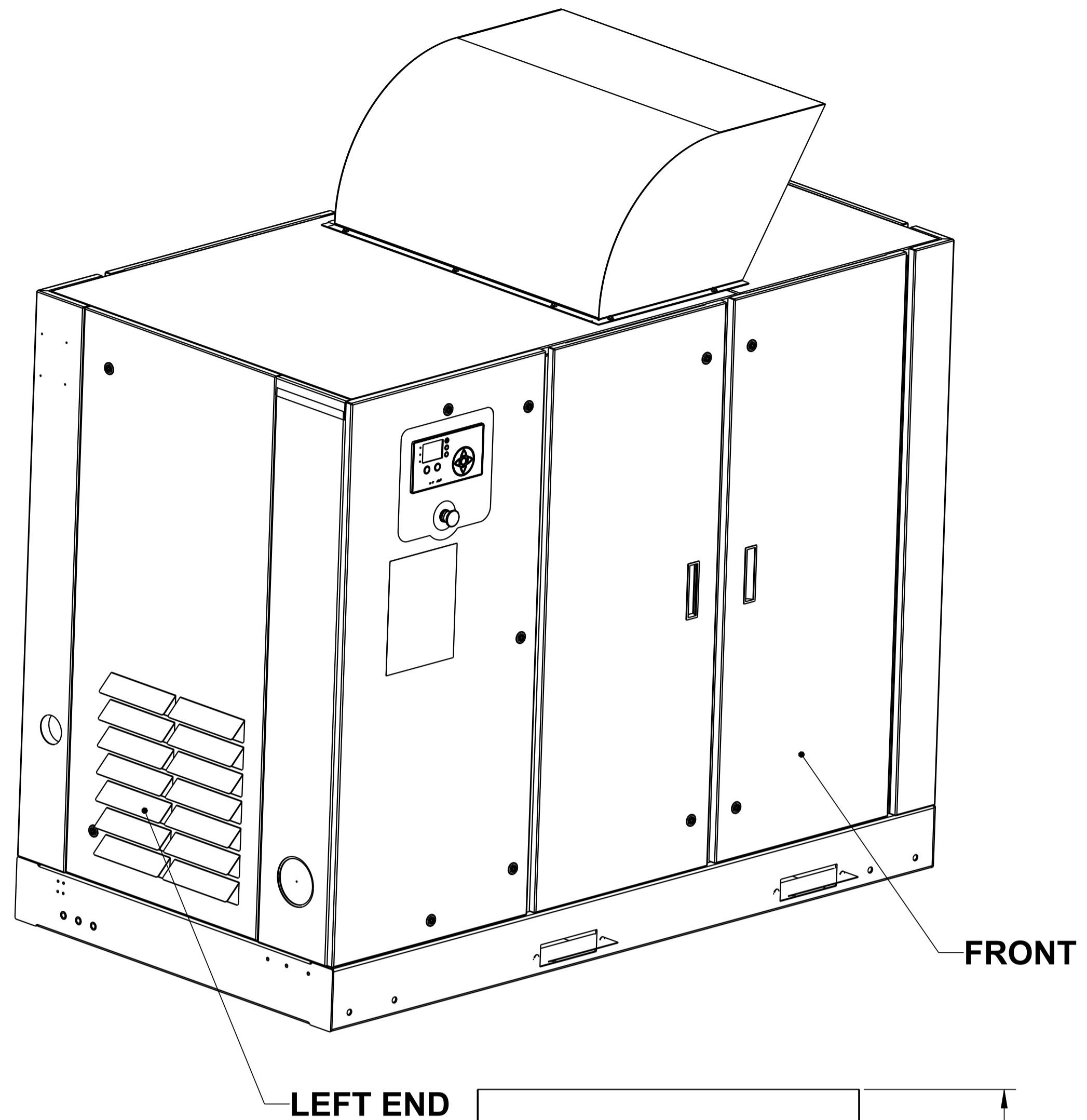

LEFT END

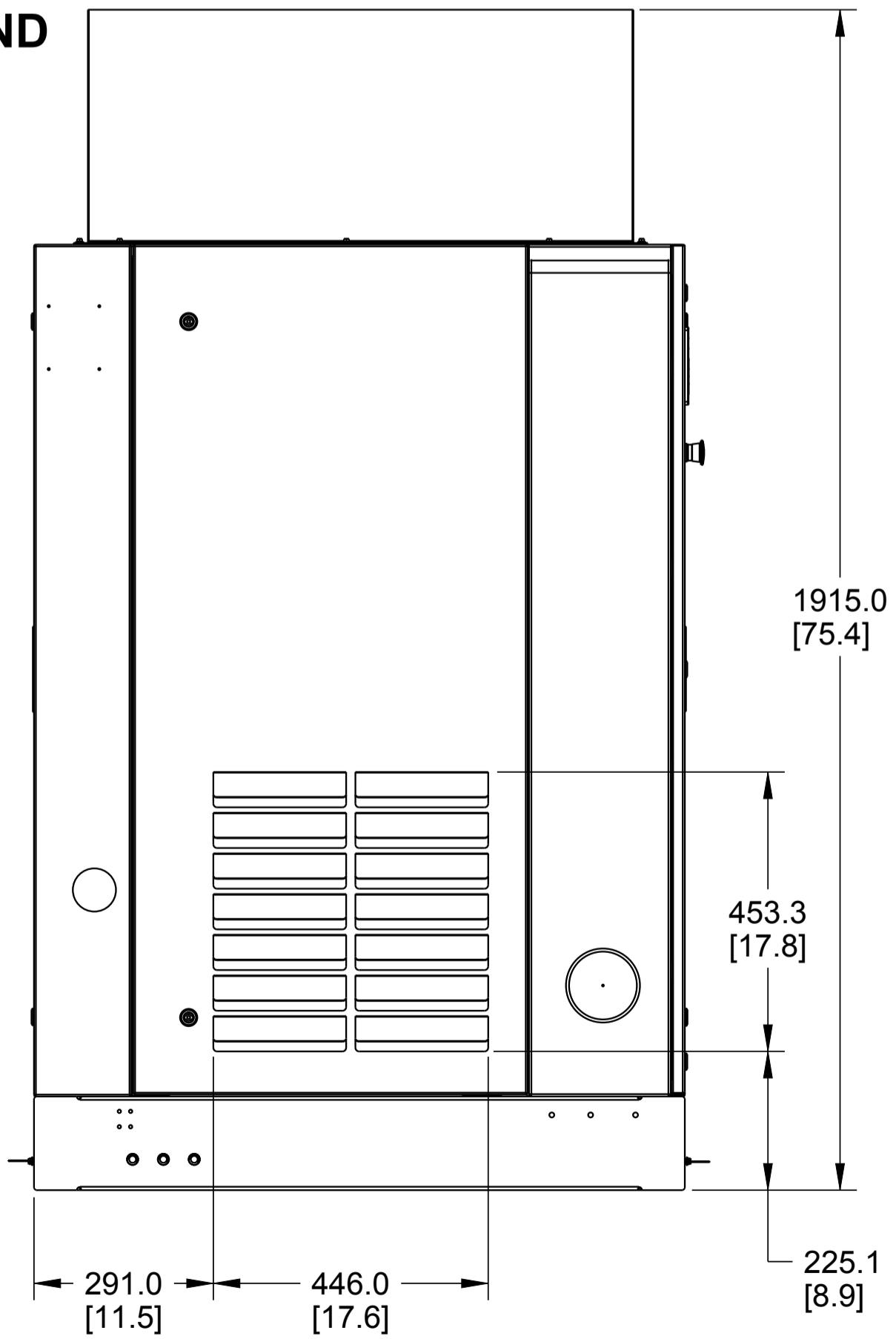

LEFT END VIEW

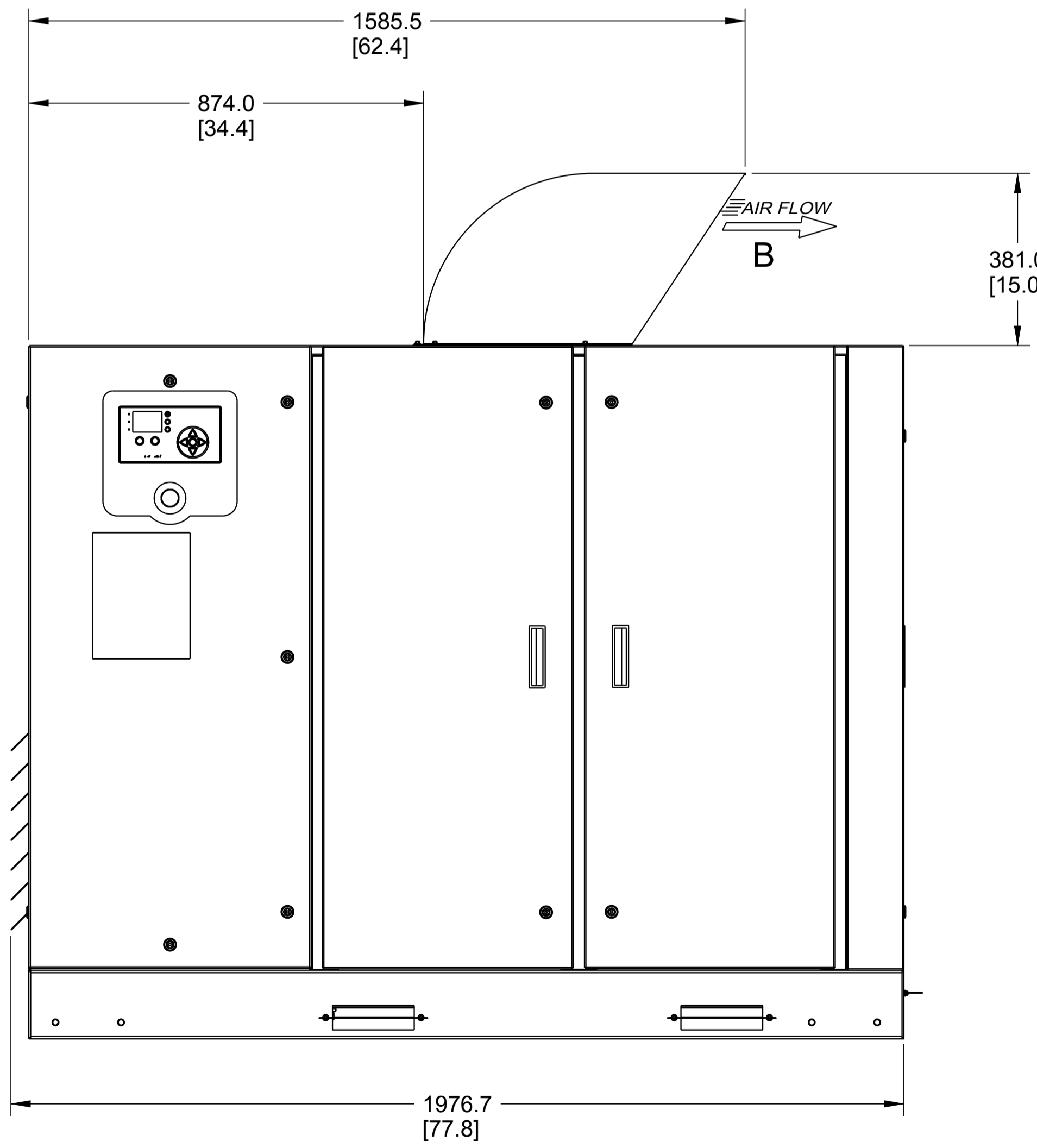

FRONT VIEW

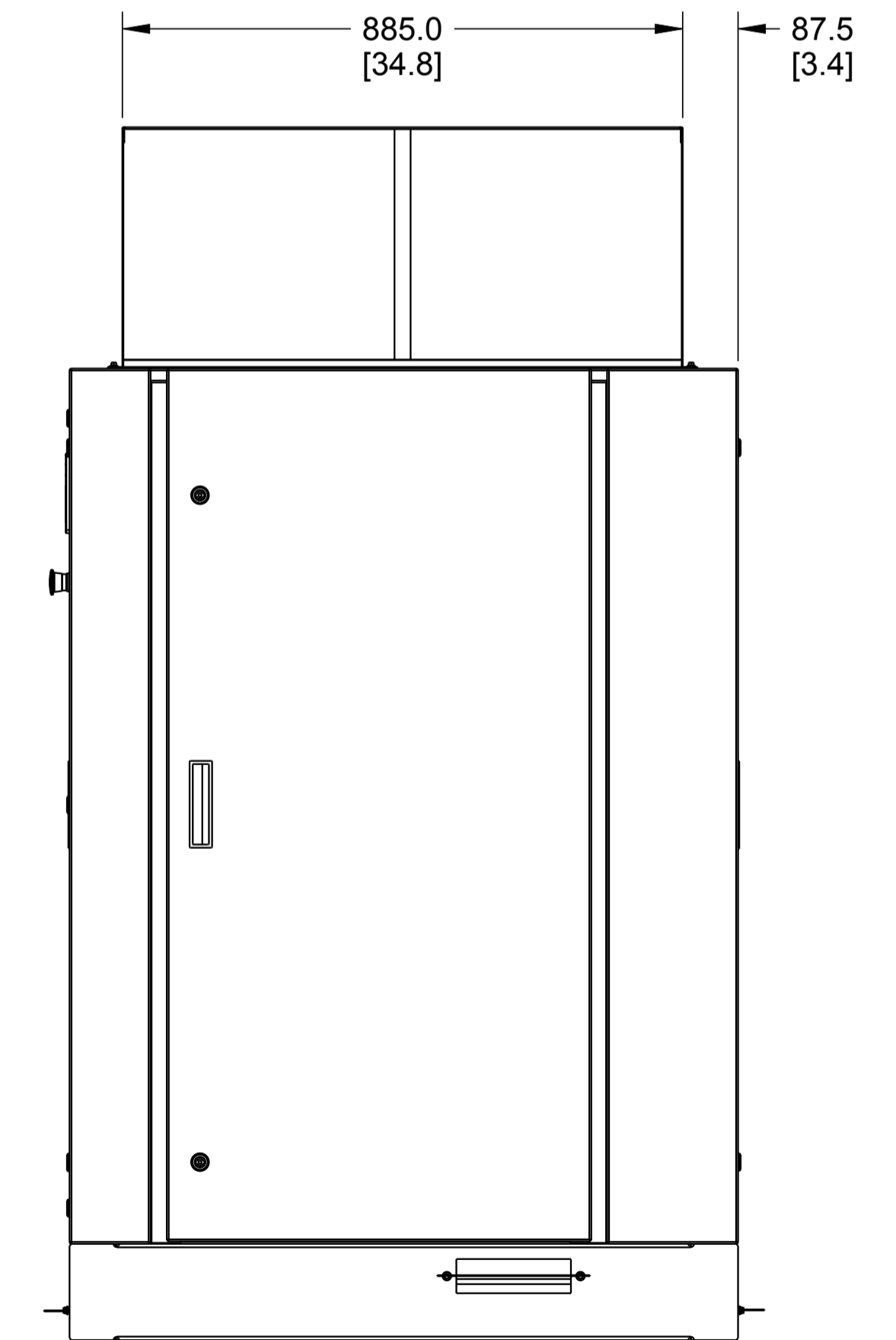

RIGHT END VIEW

<small>PROPRIETARY NOTICE</small> <small>THIS DRAWING CONTAINS CONFIDENTIAL AND TRADE SECRET INFORMATION. IS THE PROPERTY OF INGERSOLL-RAND CO. AND IS GIVEN TO THE RECEIVER IN CONFIDENCE. THE RECEIVER BY RECEIPT AND RETENTION OF THIS DRAWING ACCEPTS THE DRAWING IN CONFIDENCE AND AGREES THAT, EXCEPT AS AUTHORIZED IN WRITING BY INGERSOLL-RAND CO., IT WILL (1) NOT USE THE DRAWING OR ANY COPY THEREOF OR THE CONFIDENTIAL OR TRADE SECRET INFORMATION THEREIN; (2) NOT COPY THE DRAWING; (3) NOT DISCLOSE TO OTHERS EITHER THE DRAWING OR THE CONFIDENTIAL OR TRADE SECRET INFORMATION THEREIN; AND (4) UPON COMPLETION OF THE NEED TO RETAIN THE DRAWING OR UPON DEMAND, RETURN THE DRAWING, ALL COPIES THEREOF, AND ALL MATERIAL COPIED THEREFROM.</small>		<small>NAME</small> GENERAL ARRANGEMENT, RS30-37i,n	
<small>SIZE</small> A1	<small>DWG NO.</small> 49182587	<small>REVISION</small> C	
<small>SCALE</small> 0.20	<small>NOMENCLATURE</small>	<small>SHEET</small> 8 of 9	

GENERAL ARRANGEMENT WITH
 OPTIONAL HIGH DUST PRE-FILTER - WITH DRYER
 (OPTION IS NOT AVAILABLE FOR VSD UNITS)

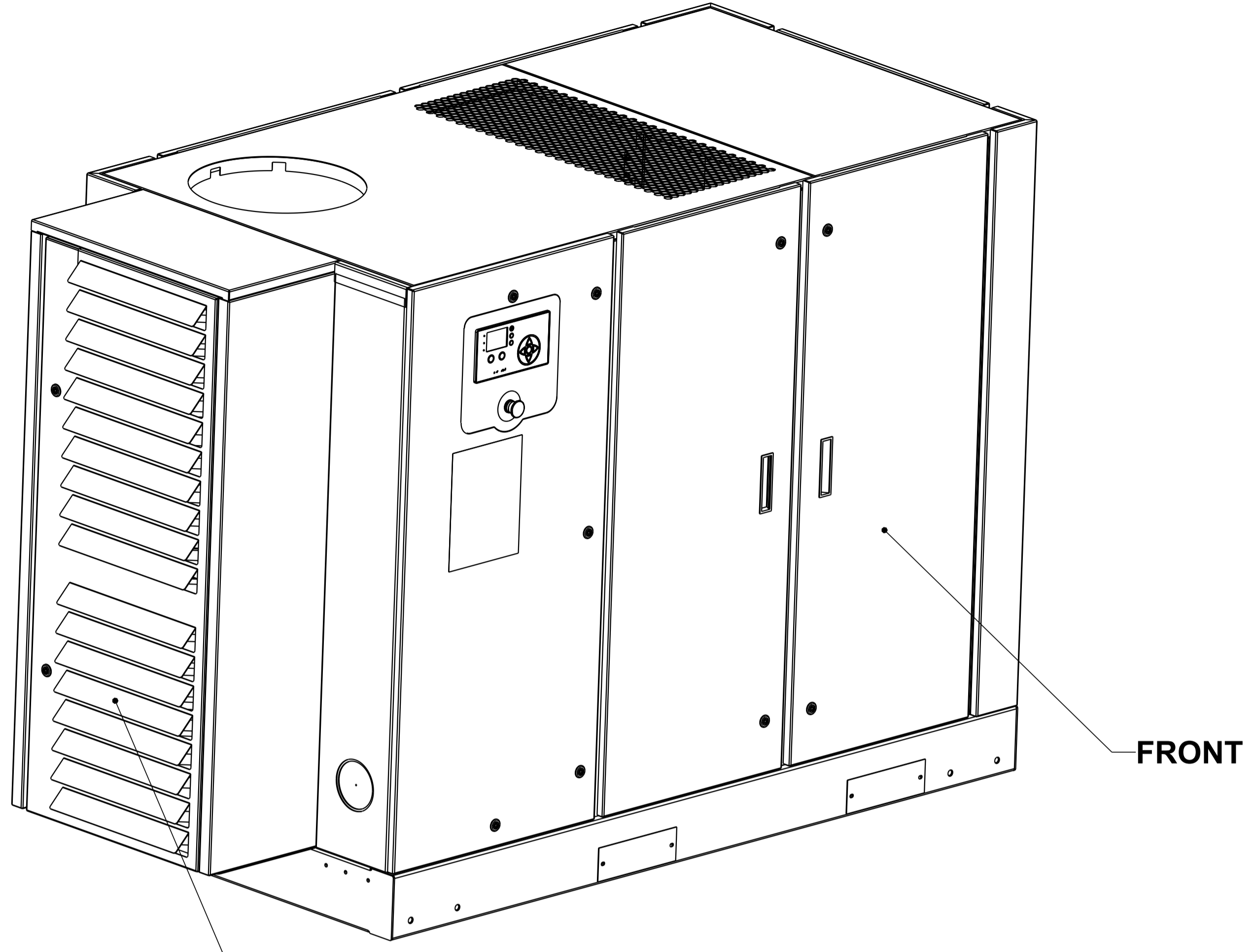

FRONT

LEFT END

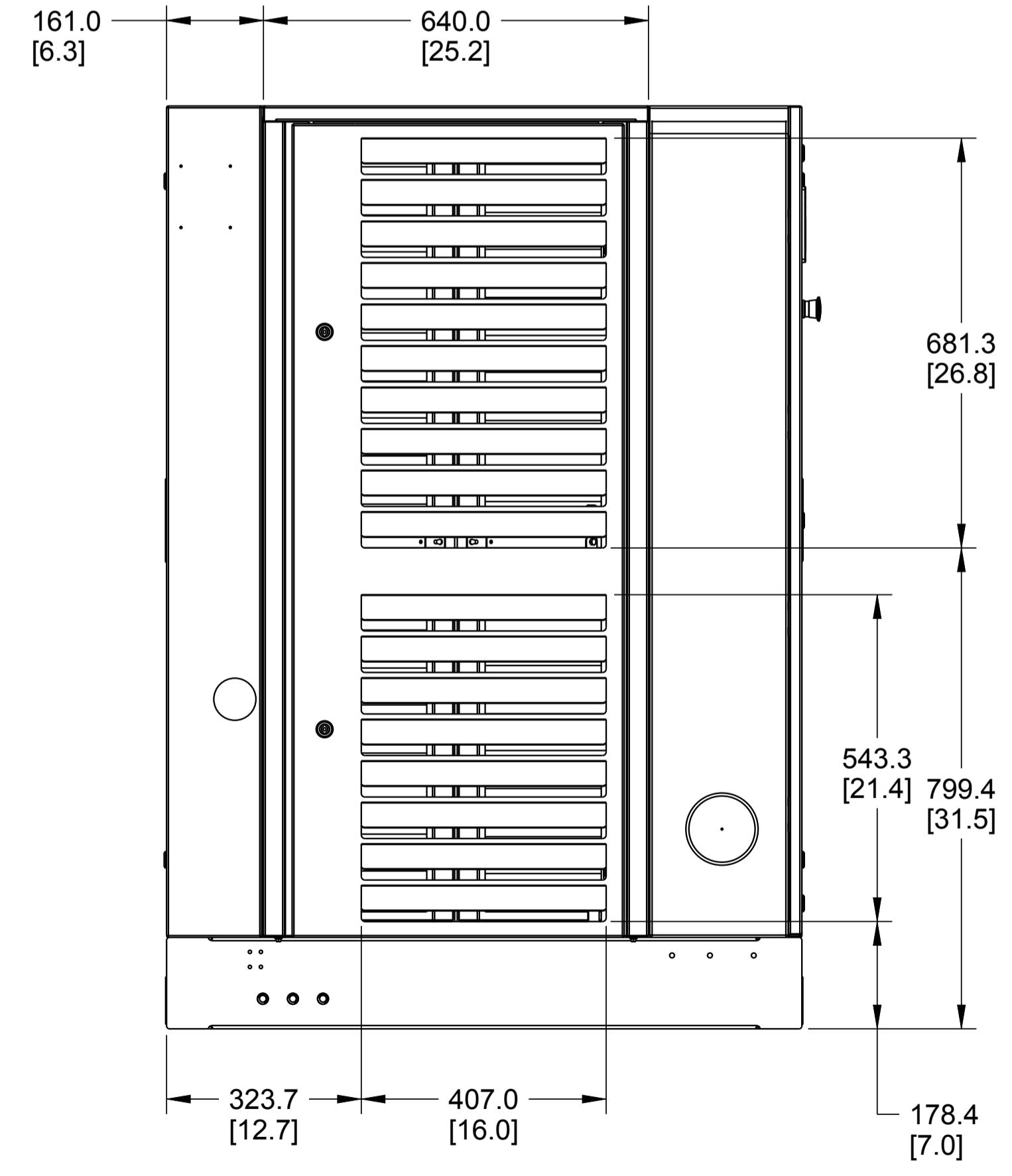

LEFT END VIEW

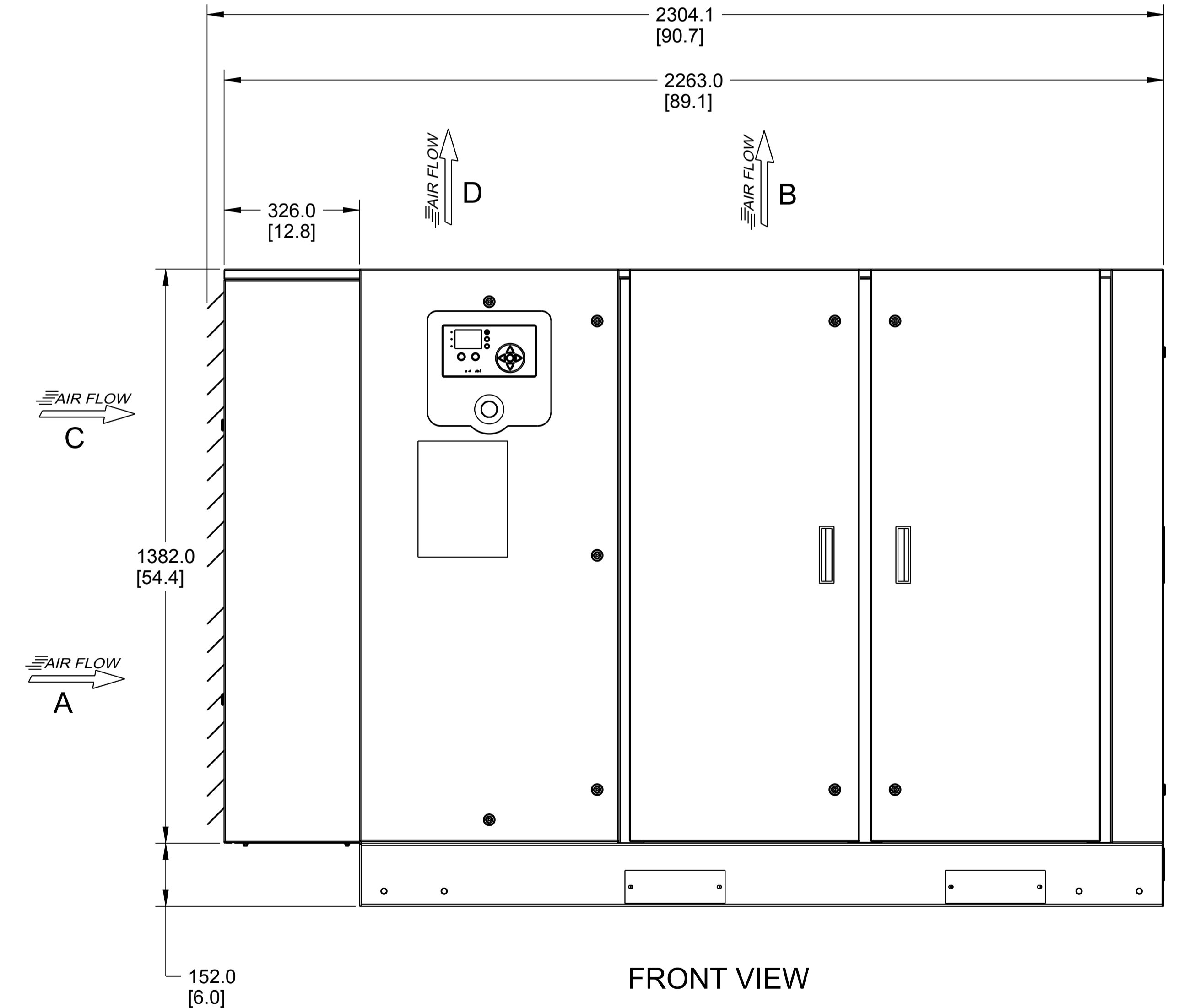

FRONT VIEW

<small>PROPRIETARY NOTICE</small> <small>THIS DRAWING CONTAINS CONFIDENTIAL AND TRADE SECRET INFORMATION. IT IS THE PROPERTY OF INGERSOLL-RAND CO. AND IS GIVEN TO THE RECEIVER IN CONFIDENCE. THE RECEIVER BY RECEIPT AND RETENTION OF THIS DRAWING ACCEPTS THE DRAWING IN CONFIDENCE AND AGREES THAT, EXCEPT AS AUTHORIZED IN WRITING BY INGERSOLL-RAND CO., IT WILL (1) NOT USE THE DRAWING OR ANY COPY THEREOF OR THE CONFIDENTIAL OR TRADE SECRET INFORMATION THEREIN; (2) NOT COPY THE DRAWING; (3) NOT DISCLOSE TO OTHERS EITHER THE DRAWING OR THE CONFIDENTIAL OR TRADE SECRET INFORMATION THEREIN; AND (4) UPON COMPLETION OF THE NEED TO RETAIN THE DRAWING, OR UPON DEMAND, RETURN THE DRAWING, ALL COPIES THEREOF, AND ALL MATERIAL COPIED THEREFROM.</small>		<small>NAME</small> GENERAL ARRANGEMENT, RS30-37i,n	
<small>SIZE</small> A1	<small>DWG NO.</small> 49182587	<small>REVISION</small> C	
<small>SCALE</small> 0.20	<small>NOMENCLATURE</small>	<small>SHEET</small> 9 of 9	