

All materials supplied are in compliance with the requirements of the List of Prohibited Substances

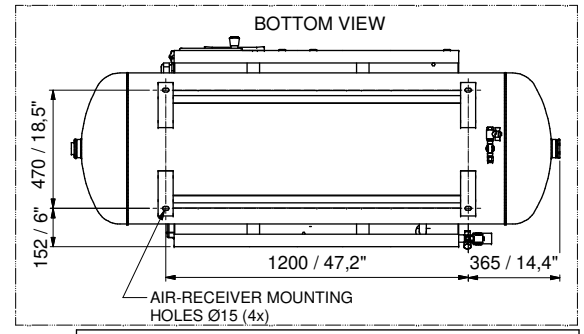
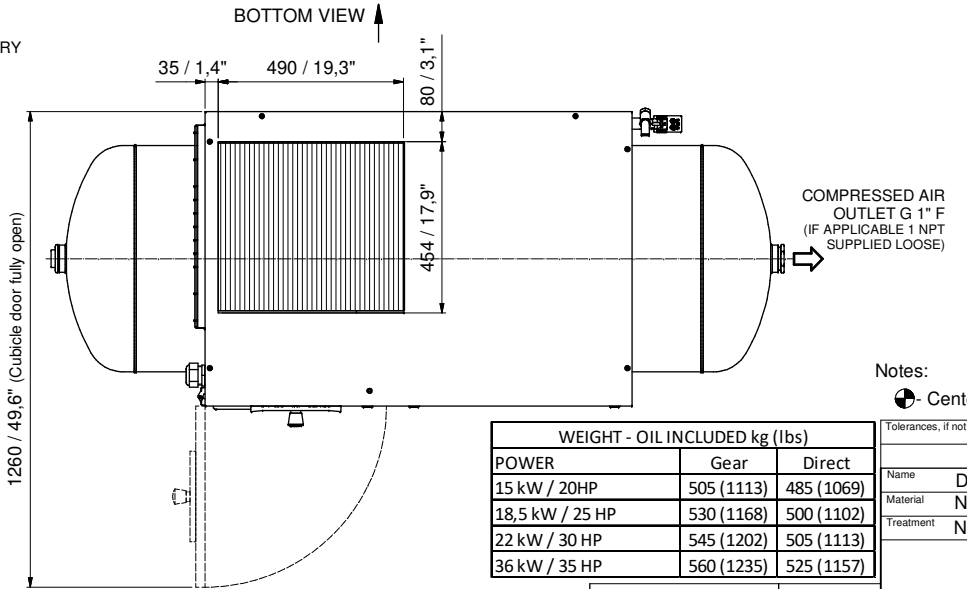
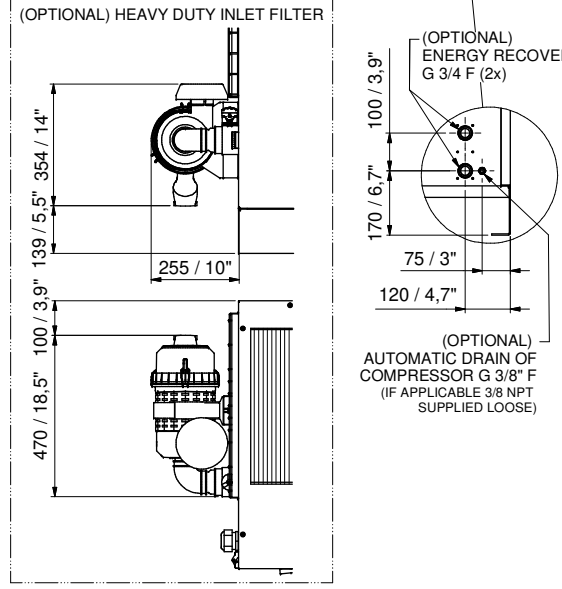
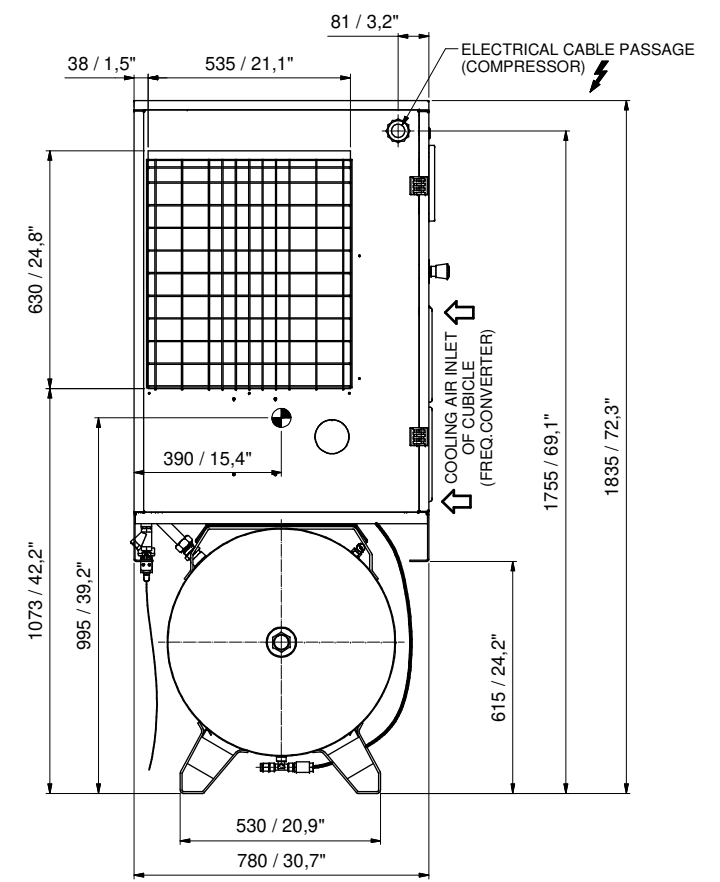
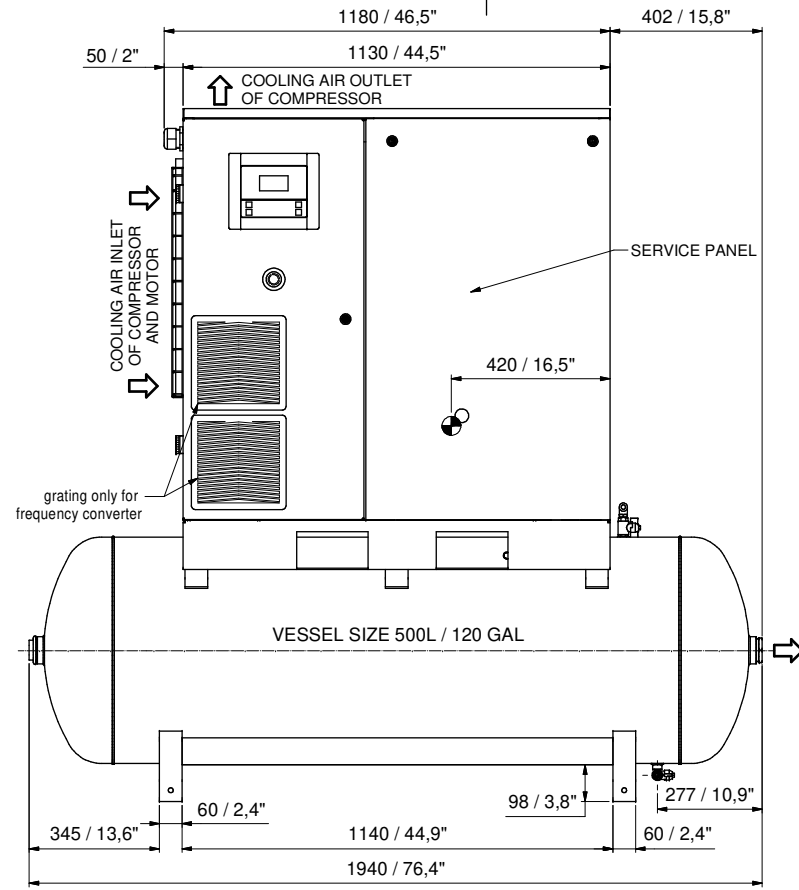
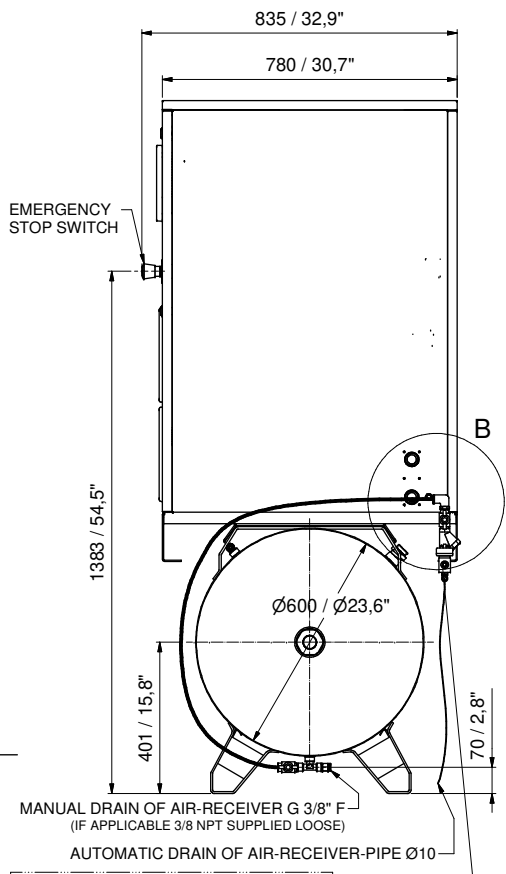

Notes:
 ● Center of gravity
 Dimensions metric (mm) / imperial (inches)
 Dimension tolerances ± 10 / 0,4" Weight tolerances ± 10 kg / 22lbs

WEIGHT - OIL INCLUDED kg (lbs)		
POWER	Gear	Direct
15 kW / 20HP	505 (1113)	485 (1069)
18,5 kW / 25 HP	530 (1168)	500 (1102)
22 kW / 30 HP	545 (1202)	505 (1113)
36 kW / 35 HP	560 (1235)	525 (1157)

Tolerances, if not indicated, according to:					
Name	DIMENSION DRAWING	C67 GD-DD PACK TM A2		Confidentiality Class acc. to 1102 K	
Material	Not Applicable	NO BAFFLE		Confidential	
Treatment	Not Applicable	INV		Drawing Owner	
Scale	1 : 10	Family	BP C67 GD-DD	Compare	
Drawn by	caisgraser	Blank nr.		Replaces	
Drawing format	Blank wt. A2	Kg	Fini wt.	N/A	Designation
STATUS	Des checked.	Prod checked.	Approved.	Date	28/09/2018
Parent 3D model					Ed. Version 3D
Approved					

CONFIDENTIAL: This document is our property and shall not be disclosed or permission be allowed. Copying, using for manufacturing or communicating to any other person or company.

01	Updated views with options - CID 27407/14-10-19 - DN 19062561	15/10/2019	sgraser
Ed	Position	Date	Intr./Appd.

9828083747
Parent 3D model
Ed. Version 3D

Sheet 1 / 1
9828083755