

All materials supplied are in compliance with the requirements of the List of Prohibited Substances

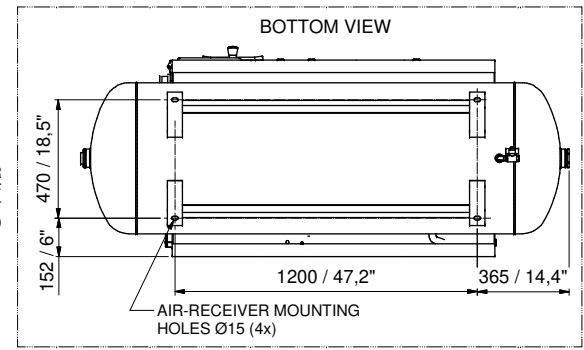
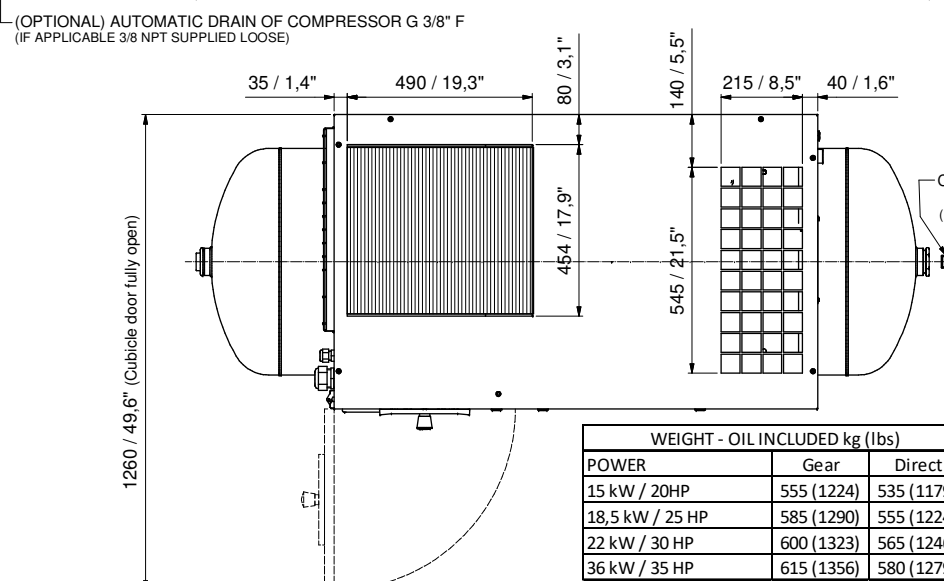
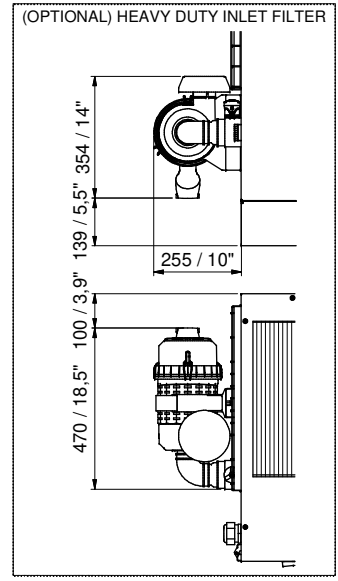
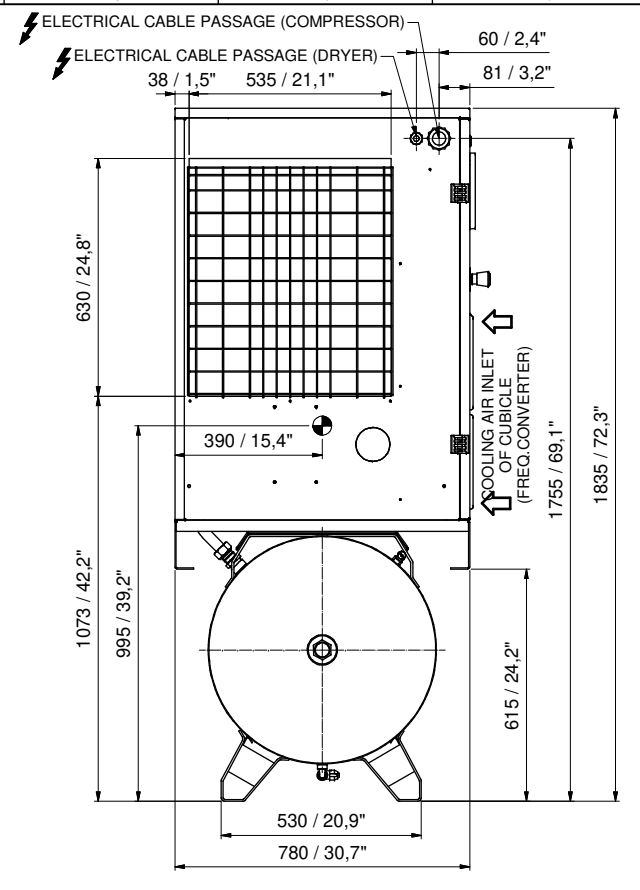
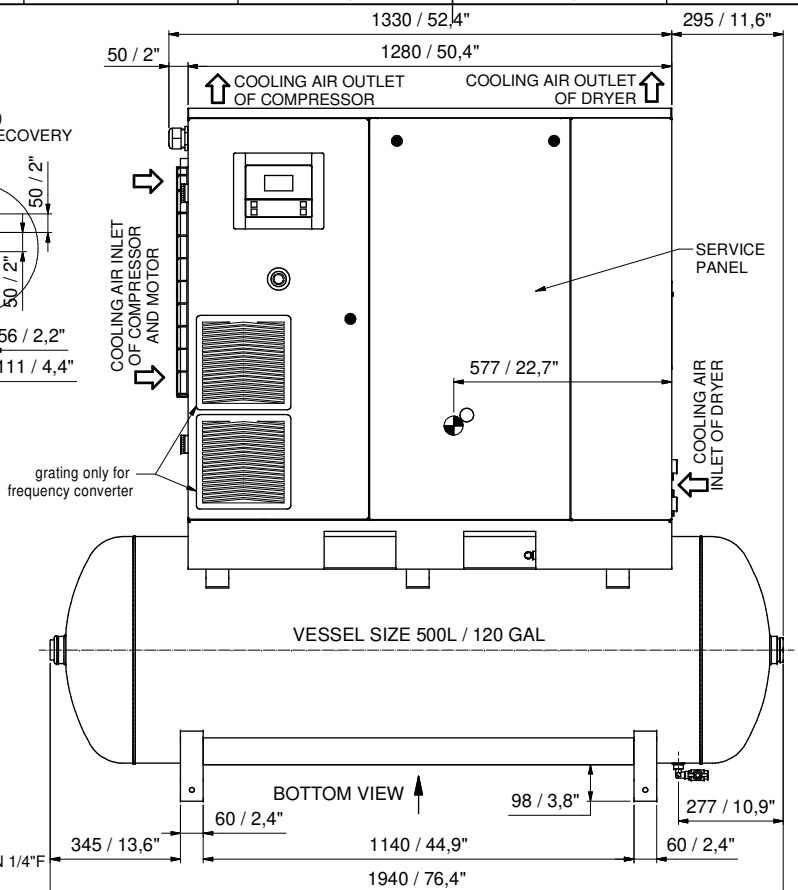
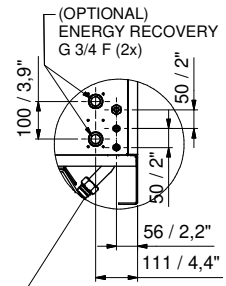
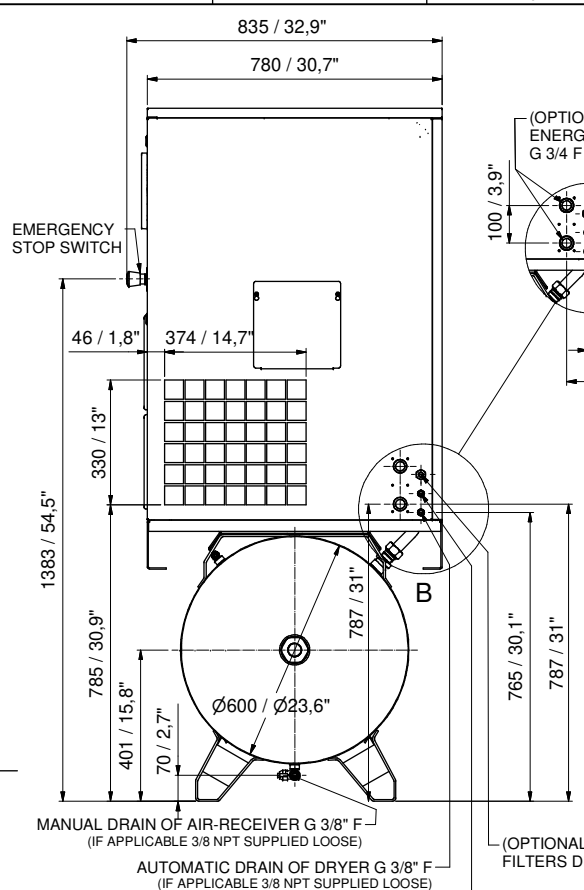

Notes:
 - Center of gravity
 Dimensions metric (mm) / imperial (inches)
 Dimension tolerances ± 10 / 0,4" Weight tolerances ± 10 kg / 22lbs
 Tolerances, if not indicated, according to:

WEIGHT - OIL INCLUDED kg (lbs)		
POWER	Gear	Direct
15 kW / 20HP	555 (1224)	535 (1179)
18,5 kW / 25 HP	585 (1290)	555 (1224)
22 kW / 30 HP	600 (1323)	565 (1246)
36 kW / 35 HP	615 (1356)	580 (1279)

Name	DIMENSION DRAWING C67 GD-DD FF TM A1-2		Confidentiality Class acc. to 1102 K
Material	Not Applicable		NO BAFFLE
Treatment	Not Applicable		INV
Scale	1 : 10	Family	BP C67 GD-DD
Drawn by	caisgraser	Blank nr.	Replaces
Drawing format	A2	Fin. wt.	N/A
STATUS	Des checked.	Prod checked.	Approved.
Date	28/09/2018		Sheet 1 / 1

01	Updated views with options - CID 27407/14-10-19 - DN 19062561	15/10/2019	sgraser
Ed	Position	Date	Intr./Appd.

9828083747	Parent 3D model	Ed. Version 3D
------------	-----------------	----------------

9828083805

CONFIDENTIAL: This document is our property and shall not without our permission be altered, copied, used for manufacturing or communication with any other person or company.