



Code	
9828093299	00
Vers. 04/2019	

USE & MAINTENANCE MANUAL

QUIET ROTARY SCREW AIR COMPRESSORS

HP 20 - 25 - 30 (IVR*) KW 15 – 18.5 - 22 (IVR*)

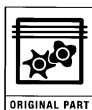

(IVR *): Variable speed compressors (INVERTER)

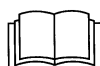
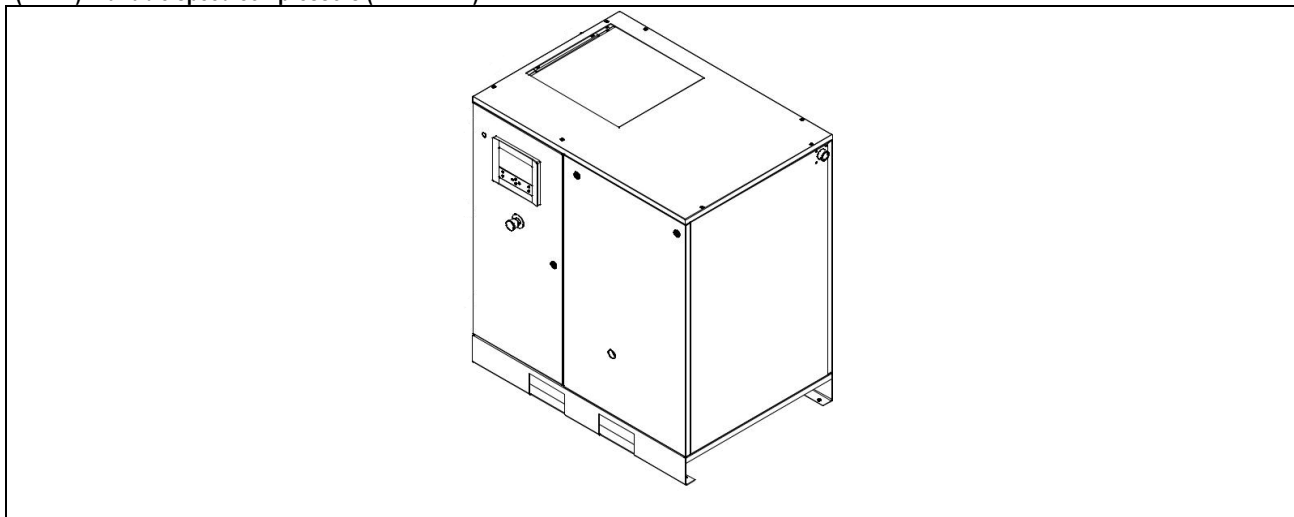

READ THIS MANUAL CAREFULLY BEFORE PERFORMING ANY OPERATIONS ON THE AIR COMPRESSOR.



ATTENTION: THE CAPACITORS INSIDE THE INVERTER MAY REMAIN LIVE FOR 15 MINUTES AFTER THE MACHINE HAS BEEN DISCONNECTED FROM THE MAINS POWER.

ACTING ON THE INVERTER BEFORE 15 MINUTES HAVE PASSED MAY ENTAIL THE RISK OF ELECTROCUTION AND DEATH.

CONTENTS	
PART A: NOTICES FOR THE USER	PART B: NOTICES RESERVED FOR PROFESSIONALLY QUALIFIED PERSONNEL
1.0 GENERAL CHARACTERISTICS	20.0 START-UP
2.0 INTENDED USE	21.0 GENERAL ROUTINE MAINTENANCE REQUIRES TRAINED PERSONNEL
3.0 OPERATING PRINCIPLE	22.0 OIL REPLACEMENT
4.0 GENERAL SAFETY REGULATIONS	23.0 OIL FILTER AND OIL SEPARATOR FILTER REPLACEMENT
5.0 DESCRIPTION OF HAZARD SYMBOLS	24.0 MOTOR BEARING GREASING (IVR ONLY)
6.0 HAZARDOUS AREAS	25.0 OLEO-PNEUMATIC DIAGRAM
7.0 SAFETY DEVICES	26.0 VARIABLE SPEED (IVR)
8.0 POSITION OF LABELS	
9.0 COMPRESSOR ROOM	
10.0 TRANSPORT & HANDLING	
11.0 UNPACKING	ATTENTION: A COPY OF THE WIRING DIAGRAMS IS INCLUDED IN THE ELECTRICAL CABINET OF THE COMPRESSOR
12.0 INSTALLATION	
13.0 OVERALL DIMENSIONS AND TECHNICAL DATA	
14.0 ILLUSTRATION OF MACHINE	
15.0 ROUTINE MAINTENANCE BY THE USER	
16.0 STORAGE	
17.0 DISMANTLING THE AIR COMPRESSOR	
18.0 SPARE PARTS LIST FOR ROUTINE MAINTENANCE	
19.0 TROUBLESHOOTING AND IMMEDIATE ACTIONS	

IDENTIFICATION DATA OF MACHINE AND MANUFACTURER

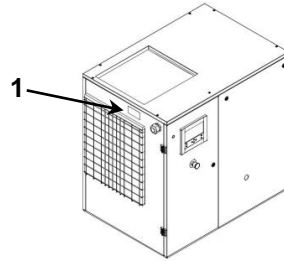

1) Position of data plate

LOCATION OF SERVICE CENTRES

In case of machine faults or malfunction, turn the machine off immediately and do not tamper with it. For eventual repairs, contact only technical service centres authorised by the manufacturer and request the use of original spare parts.

Failure to comply with the above may compromise the safety of the machine.

FOREWORD

Store this manual carefully for any future consultation; the use and maintenance manual constitutes an integral part of the machine.

Read this manual carefully before performing any operations on the compressor unit. Both the installation of the compressor unit and any operations on the same must be performed in total compliance with regulations concerning electrical installations and the safety of persons.

SAFETY CHARACTERISTICS AND PROVISIONS



MACHINE WITH AUTOMATIC RESTART

Lock Out – Tag Out (LOTTO): Open the power disconnect switch and block it with a personal padlock. Perform the power disconnect switch tag-out procedure by applying a sign with the name of the service technician.



BEFORE REMOVING THE PROTECTIONS TO SERVICE THE MACHINE, DISCONNECT THE ELECTRICAL POWER SUPPLY AND CHECK THAT THERE IS NO RESIDUAL INTERNAL PRESSURE.

ALL OPERATIONS ON THE ELECTRICAL SYSTEM, EVEN IF MINOR, MUST BE PERFORMED BY PROFESSIONALLY QUALIFIED PERSONNEL.

THIS EQUIPMENT IS NOT SUITABLE FOR OUTDOOR INSTALLATION

THIS MACHINE SATISFIES THE ESSENTIAL HEALTH AND SAFETY REQUIREMENTS OF EUROPEAN DIRECTIVE (2006/42 EC).

**LUBRICATING FLUIDS AND ANY OTHER FLUIDS MUST NEVER BE DISCHARGED IN THE ENVIRONMENT. THESE PRODUCTS, CONSIDERED POLLUTING AND HAZARDOUS, MUST NECESSARILY BE DISPOSED OF BY AUTHORISED COMPANIES SPECIALISED IN THE DIFFERENT TYPES OF PRODUCT.
SORT THE PARTS CONSTITUTING THE AIR COMPRESSOR BASED ON THE DIFFERENT TYPES OF CONSTRUCTION MATERIALS (PLASTIC, COPPER, IRON, OIL FILTER, AIR FILTER, ETC. ...)**

The manufacturer is not liable for any damage caused by failure to comply with or observe the aforementioned instructions.

1.0 GENERAL CHARACTERISTICS

The compressor units use single stage oil-injected rotary screw air compressors.

The unit includes:

compressor; oil separator; oil cooler and output air cooler; fan; electric starter; safety and regulation devices, instrument panel.

The system is self-supporting and does not require any bolts or floor anchoring devices.

The unit is completely factory assembled; the connections necessary for its operation are:

- connection to mains power: (see installation chapter)
- connection to compressed air network: (see installation chapter)

The compressor-motor unit is mounted on the frame of the machine by means of elastic supports: this allows the compressor unit to be rested directly on the floor without the need for any additional anti-vibration elements.

2.0 INTENDED USE

The compressor unit has been developed to supply compressed air for industrial use. **In any case, the machine cannot be used in places with an explosion or fire hazard, that is, in places where works are performed that release hazardous substances posing a risk to safety into the environment (for example: solvents, flammable vapours, alcohols, etc. ...).** In particular, the equipment cannot be used to produce air intended for human respiration or used in direct contact with food substances. These uses are allowed if the compressed air is treated using a suitable filtration system. (Consult with the manufacturer for these special uses).

This equipment must be used only in accordance with the use for which it was expressly designed.

All other uses shall be considered improper and therefore unreasonable. The Manufacturer shall not be held liable for any damage caused by improper, erroneous and unreasonable uses.

3.0 OPERATING PRINCIPLE

3.1 OPERATING PRINCIPLE OF SCREW COMPRESSOR

The electric motor and compressor unit are coupled by means of a gear transmission / elastic coupling. The compressor unit withdraws air from the outside through the intake valve. The withdrawn air is filtered by the filter cartridge installed upstream of the intake valve. Inside the compressor unit, the air and lubricating oil are compressed and sent to the oil separator, where the oil is separated from the compressed air; the latter is filtered again by the oil separator cartridge to reduce the suspended oil particles to a minimum. At this point the two flows (of oil and air) are sent to two distinct coolers where they are cooled, using an air flow withdrawn from the outside using a special fan inside the machine. The cooled oil is placed back into circulation.

4.0 GENERAL SAFETY REGULATIONS

Use of the equipment is allowed only by properly trained and authorised personnel.









All and any tampering with or modifications to the equipment not previously authorised by the Manufacturer shall release the latter from all liability for any damage resulting from or attributable to the aforementioned actions. The removal of or tampering with safety devices constitutes violation of European Safety Standards

ATTENTION: A DISCONNECT SWITCH WITH AUTOMATIC OVERCURRENT PROTECTION DEVICE, EQUIPPED WITH DIFFERENTIAL DEVICE MUST BE INSTALLED; SEE WIRING DIAGRAMS FOR CALIBRATIONS.



ALL OPERATIONS ON THE ELECTRICAL SYSTEM, EVEN IF MINOR, MUST BE PERFORMED BY PROFESSIONALLY QUALIFIED PERSONNEL.

5.0 DESCRIPTION OF HAZARD SYMBOLS

	1) FLUID EJECTION		6) HOT PARTS
	2) HAZARDOUS VOLTAGE		7) MOVING PARTS
	3) NON-RESPIRABLE AIR		8) ROTATING FAN
	4) NOISE		9) MACHINE WITH AUTOMATIC RESTART
	5) HIGH PRESSURE		

5.1 DESCRIPTION OF OBLIGATION SYMBOLS

	11) READ THE USE & MAINTENANCE INSTRUCTIONS		
---	---	--	--

6.0 HAZARDOUS AREAS

6.1 HAZARDOUS AREAS FOR SCREW COMPRESSOR

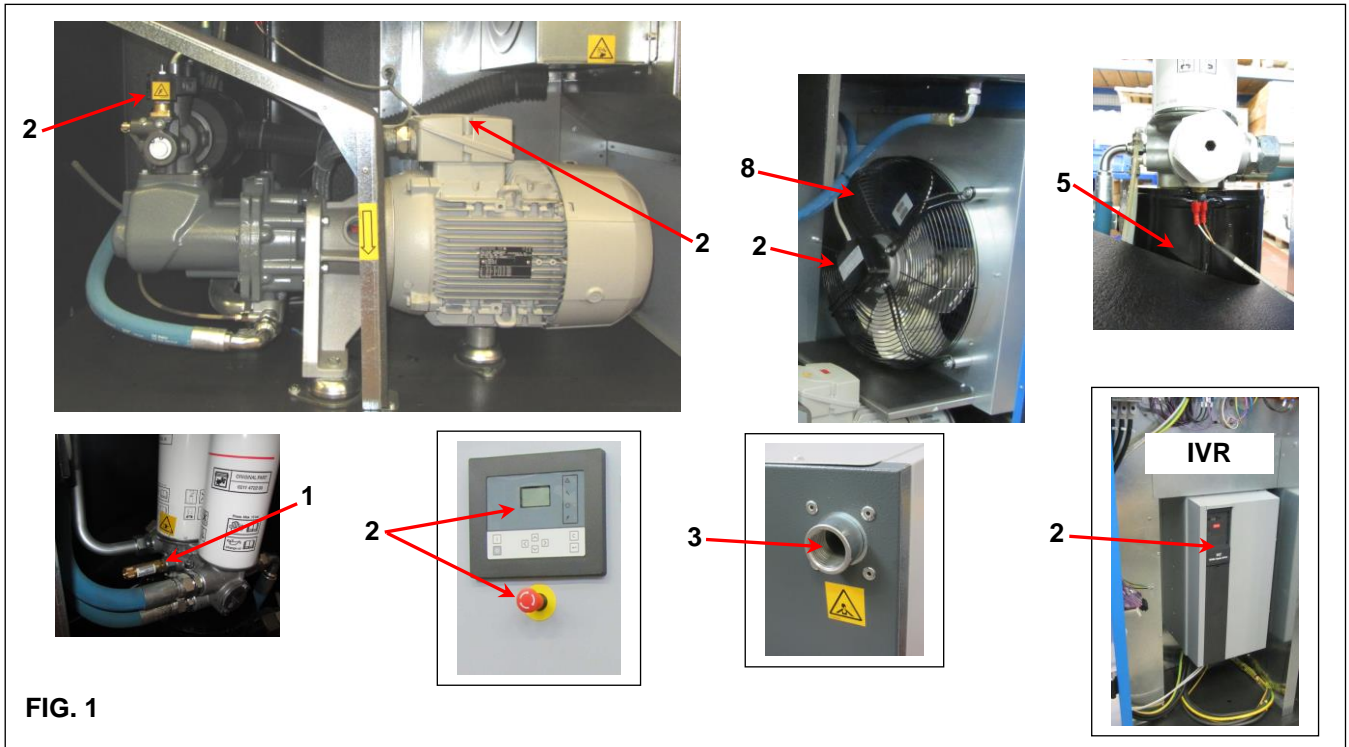
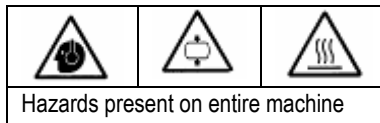
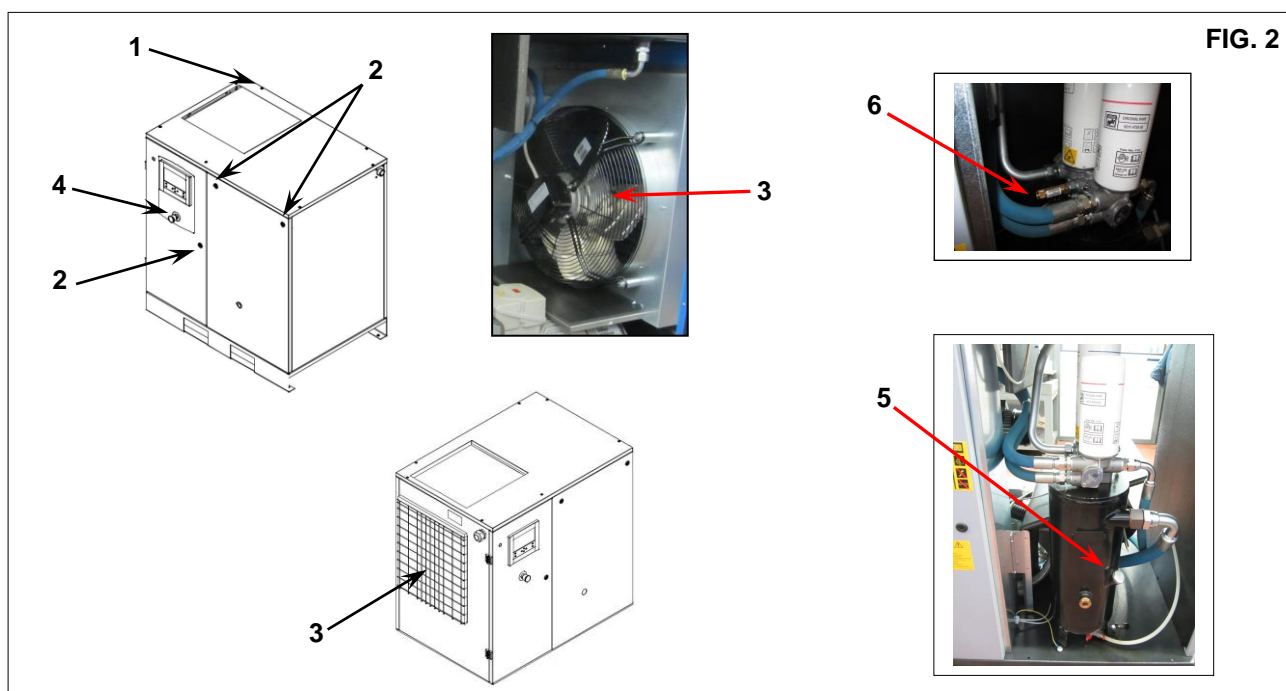

FIG. 1

				
1	2	3	5	8

7.0 SAFETY DEVICES**7.1 SAFETY DEVICES FOR SCREW COMPRESSOR (Fig. 2)**

1) Security screws	4) Self-locking twist to release emergency button
2) Panel and door to electrical cabinet, openable with special key	5) Oil fill cap (with breather)
3) Fixed fan protection	6) Safety valve



8.0 POSITION OF LABELS

8.1 POSITION OF HAZARD LABELS FOR SCREW COMPRESSOR

The labels applied to the compressor unit are part of the machine and have been applied for safety reasons and must not be detached or ruined for any reason whatsoever.

1) Hazard label Cod. 1079 9903 48

2) Label: "Machine with automatic restart 2202 2607 91

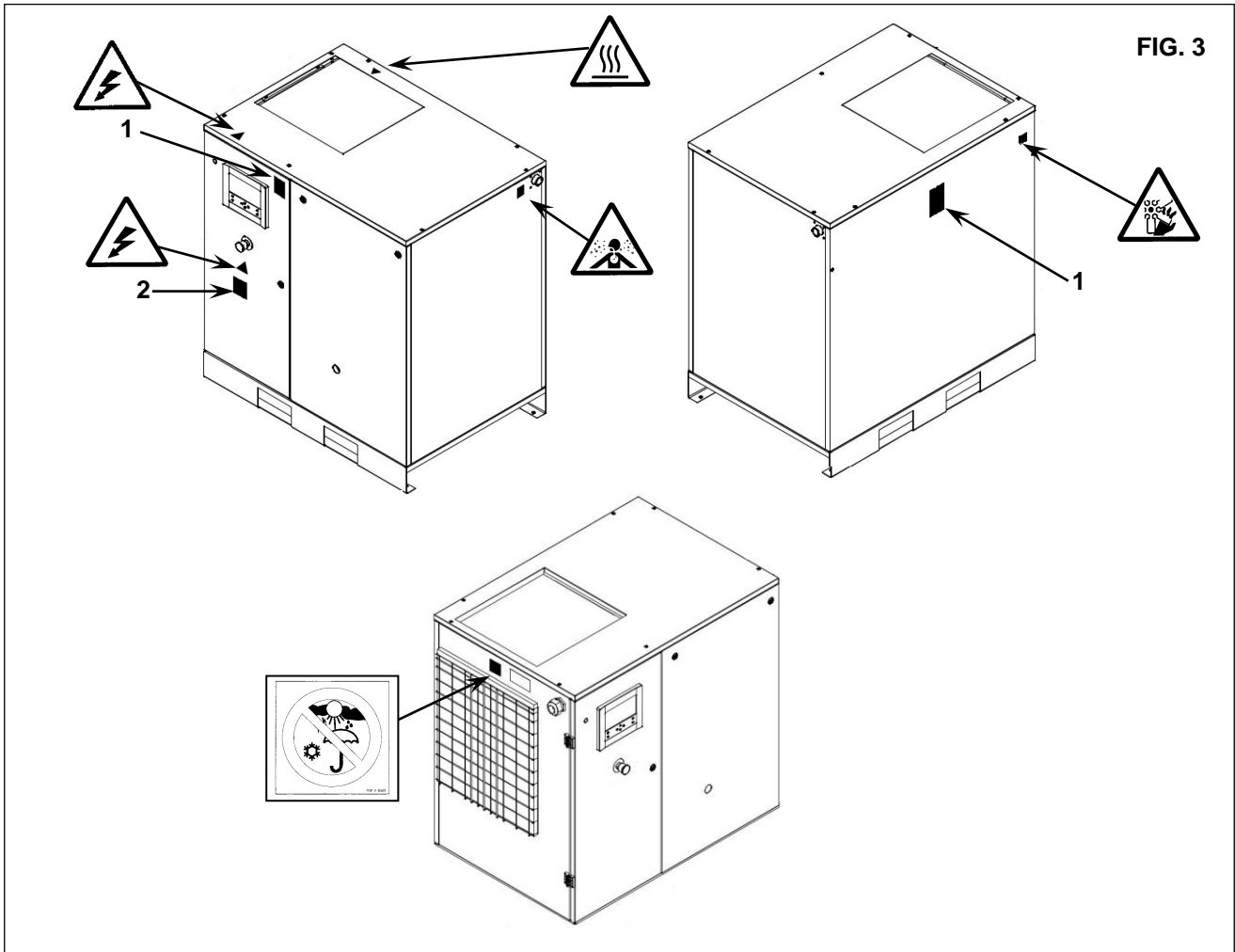

8.3 POSITION OF INFORMATIVE LABELS FOR SCREW COMPRESSOR

- 1) Data plate 2) Direction of rotation
3) Drain condensate water 4) General hazards

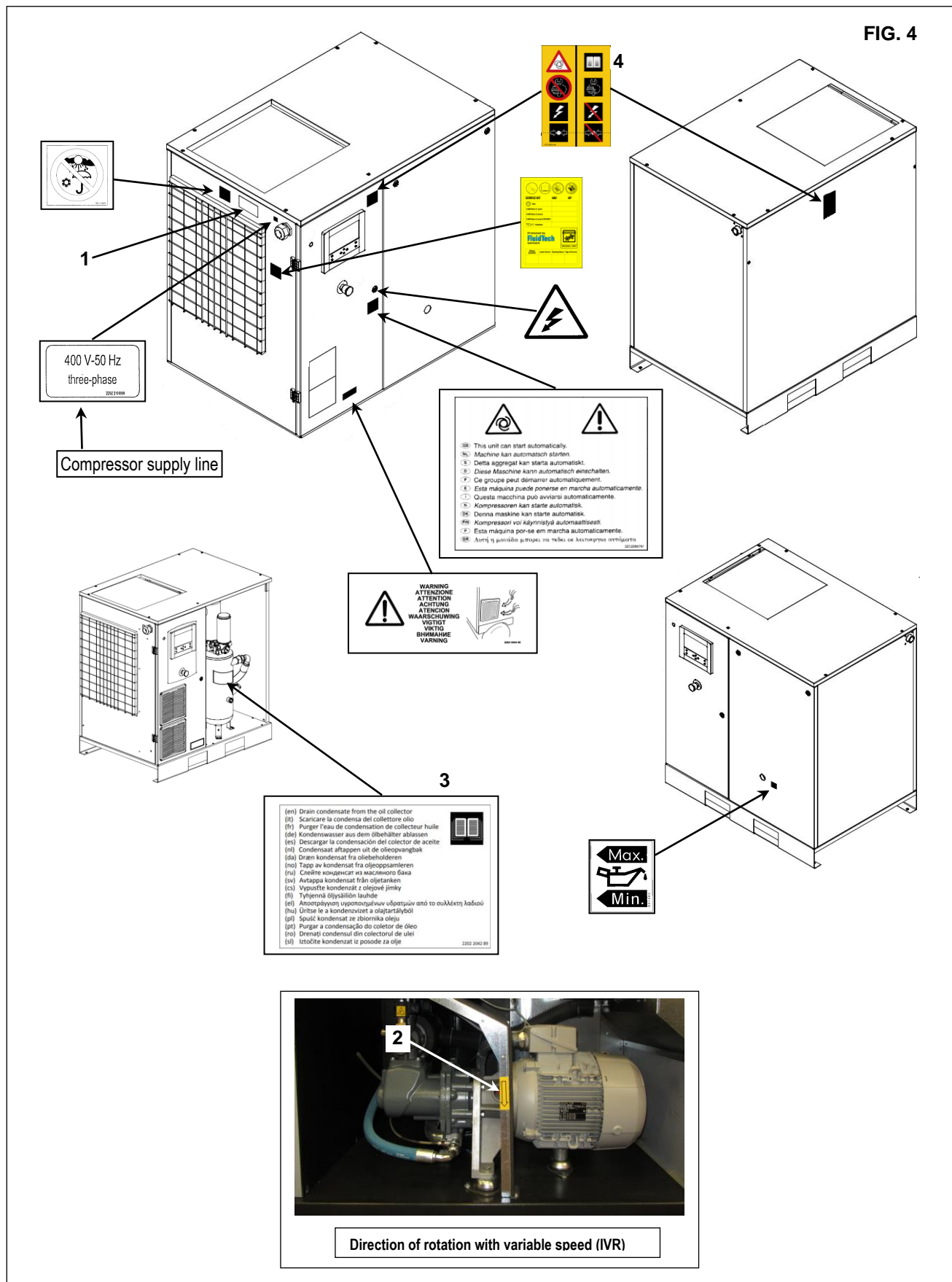

9.0 COMPRESSOR ROOM

9.1 FLOORING

The flooring must be level and of the industrial type, the overall machine weight is reported in Chap. 13.0. Keep the overall machine weight in mind for its positioning.

9.2 VENTILATION

An appropriate choice of room will extend the service life of your compressor; the room must be large, dry, well-ventilated and not dusty. The ambient temperature, with the machine running, must not exceed **46°C** and must not be less than **1°C**. The room must have a volume of approximately **60 m³**. The room must have 2 openings for ventilation, each having a surface area of approximately **0.5 m²**. The first opening must be positioned up high to allow the evacuation of hot air, the second opening must be positioned down low to allow the intake of external ventilation air. In the case of dusty environments, it is recommended to install a panel filter on these openings.

9.3 EXAMPLES OF COMPRESSOR ROOM VENTILATION

ATTENTION:
Removable duct to clean
the radiator

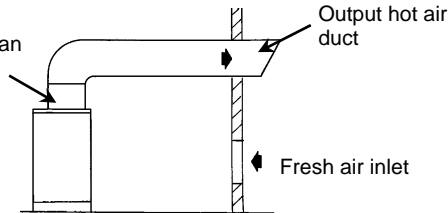

Fan air outlet

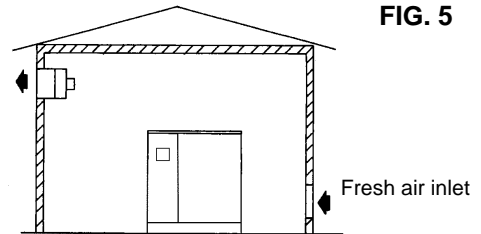
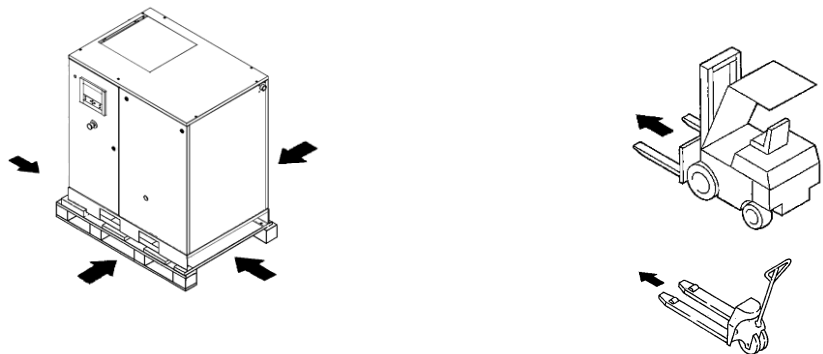

FIG. 5

10.0 TRANSPORT & HANDLING

The machine must be transported as specified in the following figures.



11.0 UNPACKING

After having removed the packaging, inspect the integrity of the machine and check that there are no visibly damaged parts. In case of doubt, do not use the machine and contact the manufacturer's service centre or your retailer. Packing materials (plastic bags) must not be left within reach of children or dispersed in the environment insofar as they are potential sources of danger and pollution. Deposit such materials in dedicated collection areas.

12.0 INSTALLATION**12.1 POSITIONING**

After having unpacked and set up the compressor room, position the machine, performing the following checks:

- check that there is sufficient space around the machine for servicing (see Fig. 7)

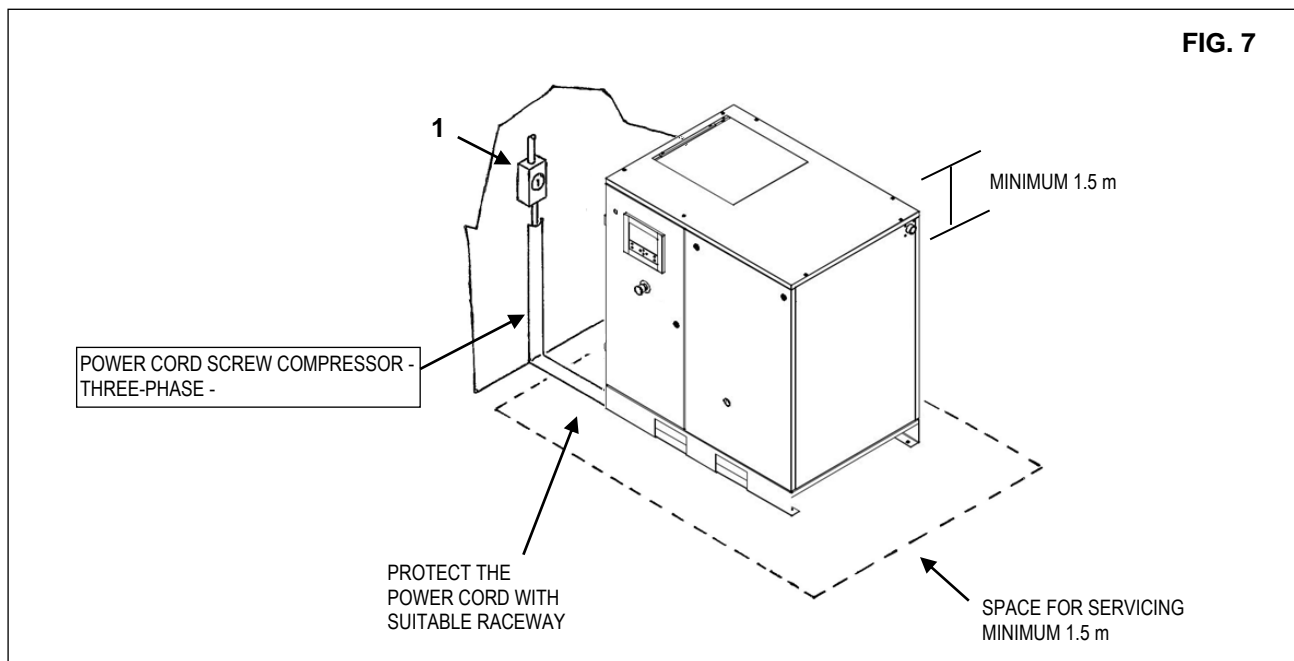

CHECK THAT THE OPERATOR HAS A FULL VIEW OF ALL THE EQUIPMENT FROM THE CONTROL PANEL AND CHECK THAT THERE ARE NO UNAUTHORISED PERSONS IN THE VICINITY OF THE MACHINE.

12.2 ELECTRICAL CONNECTION

- Check that the supply voltage corresponds to the value on the machine data plate.
- Check the condition of the line conductors and for the presence of an efficient ground conductor.
- Check for the existence, upstream of the machine, of an automatic overcurrent protection device, equipped with differential device (Ref. 1 for screw compressor), see wiring diagram.
- Connect the electrical cables of the machine with utmost care in compliance with current standards. Such cables must be developed as indicated by the machine's wiring diagram.
- Check the cables connected to the terminal block of the electrical cabinet and make sure they are properly tightened (**tightening torque provided in wiring diagram**).

The torque of the electrical terminal screws must be checked after the first 50 running hours.



ACCESS TO THE ELECTRICAL CABINET IS ALLOWED ONLY BY PROFESSIONALLY QUALIFIED PERSONNEL. BEFORE OPENING THE DOOR OF THE ELECTRICAL CABINET, DISCONNECT THE POWER. COMPLIANCE WITH LEGISLATION IN FORCE REGARDING ELECTRICAL INSTALLATIONS IS ESSENTIAL TO ENSURE THE SAFETY OF WORKERS AND PROTECTION OF THE MACHINE

THE CABLES, PLUGS AND ANY OTHER TYPE OF ELECTRICAL MATERIAL USED TO MAKE THE CONNECTION MUST BE SUITABLE FOR USE AND SATISFY THE REQUIREMENTS OF LEGISLATION IN FORCE.

ENGLISH

12.3 CONNECTION TO COMPRESSED AIR DISTRIBUTION NETWORK

Insert a manual shut-off valve Ref. 1 between the machine and the compressed air distribution network to allow the compressor to be isolated from the network during servicing (see figure 8).



TUBES, FITTINGS AND COUPLINGS FOR THE CONNECTION OF THE ELECTRIC COMPRESSOR TO THE COMPRESSED AIR DISTRIBUTION NETWORK MUST BE SUITABLE FOR USE IN COMPLIANCE WITH THE PROVISIONS OF LEGISLATION IN FORCE IN THE COUNTRY OF INSTALLATION.

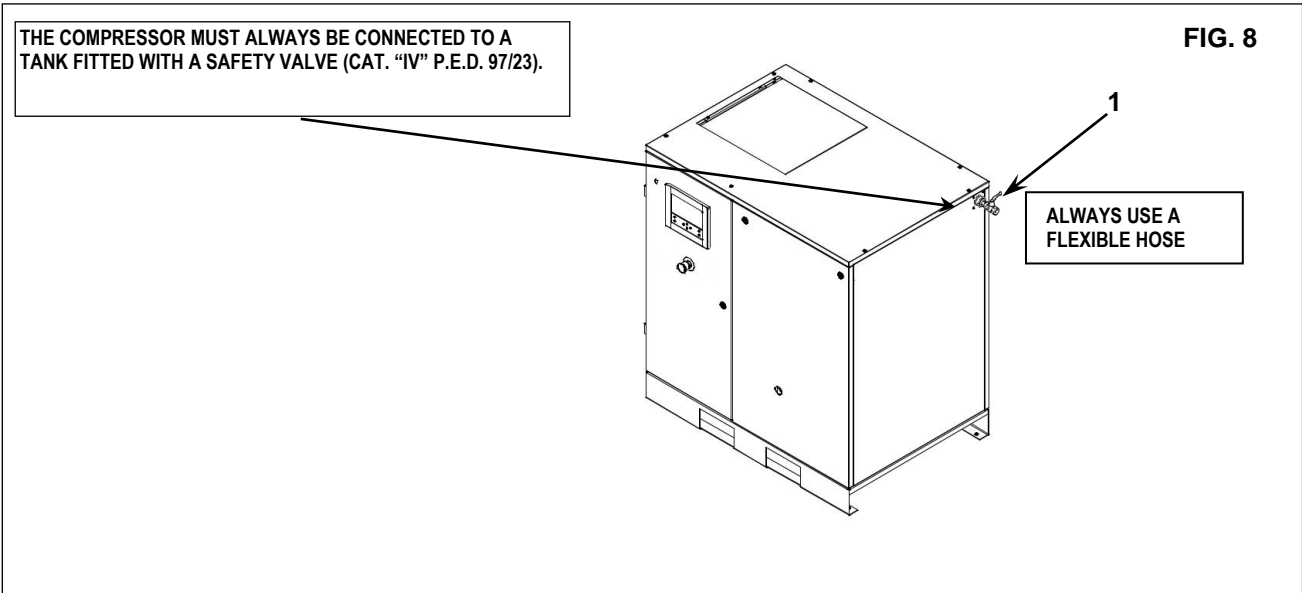

THE MANUFACTURER SHALL NOT BE LIABLE FOR ANY DAMAGE CAUSED BY FAILURE TO OBSERVE THE AFOREMENTIONED INSTRUCTIONS, WHICH MAY ALSO CAUSE THE INVALIDATION OF THE WARRANTY TERMS.

12.4 START-UP

See part B of this manual in **Chap. 20.0**

13.0 OVERALL DIMENSIONS AND TECHNICAL DATA

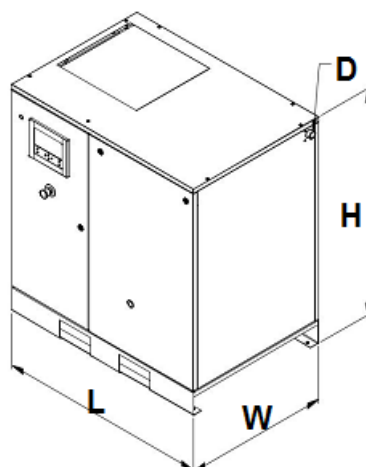

	Dimensions (mm)			Air couplings
	L	W	H	D
HP 20-35 - kW 15-26	1200	835	1220	1"
	Weight (Kg)			
HP 20 - kW 15				310 (IVR)
HP 25 - kW 18.5				325 (IVR)
HP 30 - kW 22				330 (IVR)

	HP 20 (IVR) kW 15 (IVR)			HP 25 (IVR) kW 18.5 (IVR)			HP 30 (IVR) kW 22 (IVR)		
Max. pressure bar	13			13			13		
Rated pressure bar	7	9.5	12.5	7	9.5	12.5	7	9.5	12.5
Standard air flow rate m3/h:	178	152	131	215	185	149	240	207	185
Noise dB(A)	68			70			71		
Oil thermostat calibration °C	115°C			115°C			115°C		
Oil load lt.	10 lt.			10 lt.			10 lt.		

14.0 ILLUSTRATION OF MACHINE

14.1 GENERAL LAYOUT FOR SCREW COMPRESSOR

- 1 Air intake filter
- 2 Thermostatic valve
- 3 Oil filter
- 4 Air-oil cooler
- 6 Minimum pressure valve
- 7 Air/oil separator filter
- 8 Oil top-up or fill cap
- 9 Electrical cabinet panel
- 10 Oil level
- 11 Oil/condensate drain (oil catcher)
- 12 Oil catcher
- 13 Electronic control board
- 14 Safety valve (*)
- 15 Fan motor
- 16 Electric motor
- 17 Screw compressor
- 18 Air intake unit
- 19 Cyclone water separator (WSD)

*** IT IS PROHIBITED TO TAMPER WITH THE CALIBRATION OF THE SAFETY VALVE**

FIG. 9

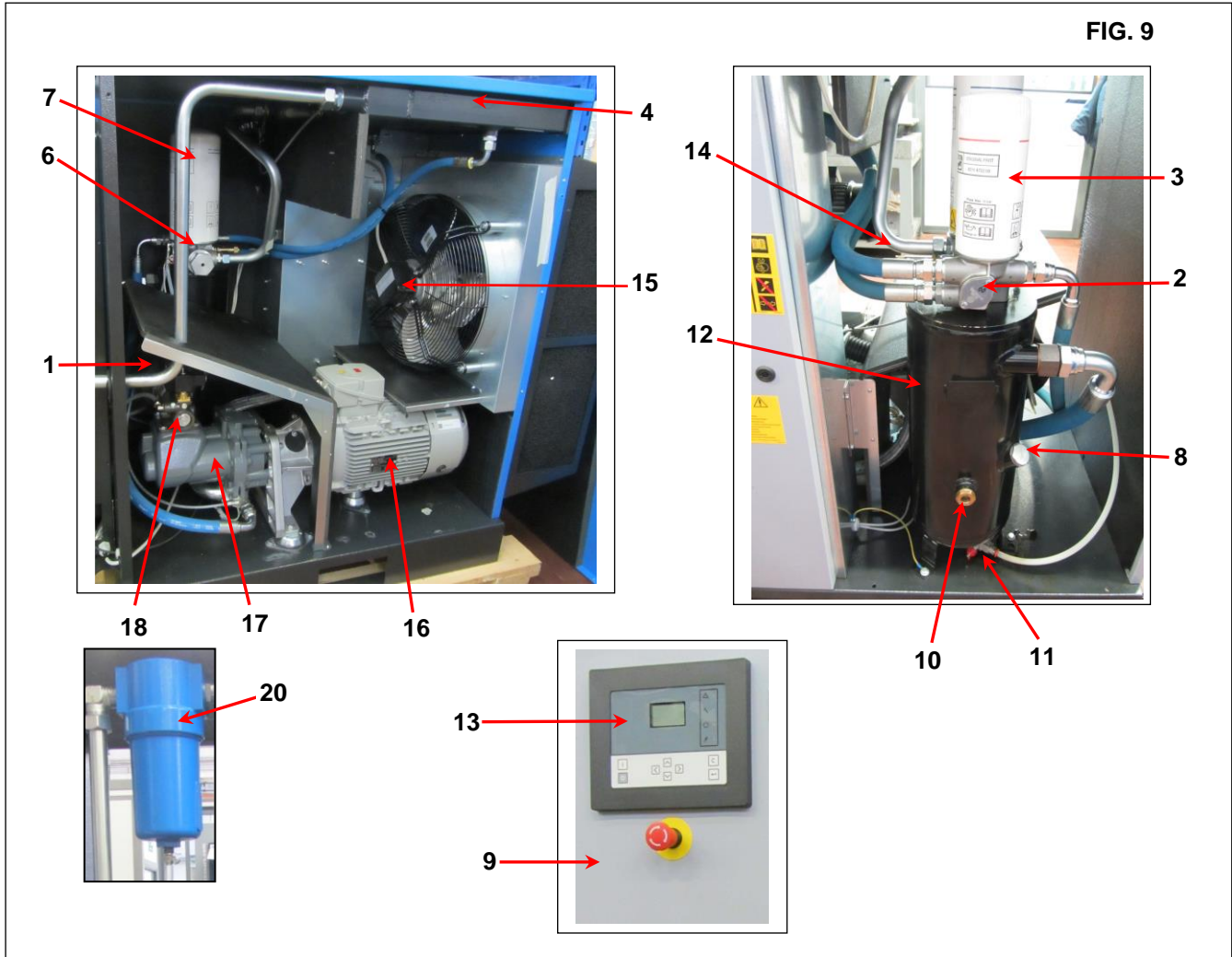

14.2 CONTROL PANEL AND COMMANDS



BEFORE PERFORMING OPERATIONAL TESTS, READ AND FULLY COMPREHEND THE FUNCTIONS OF THE CONTROLS AND COMMANDS

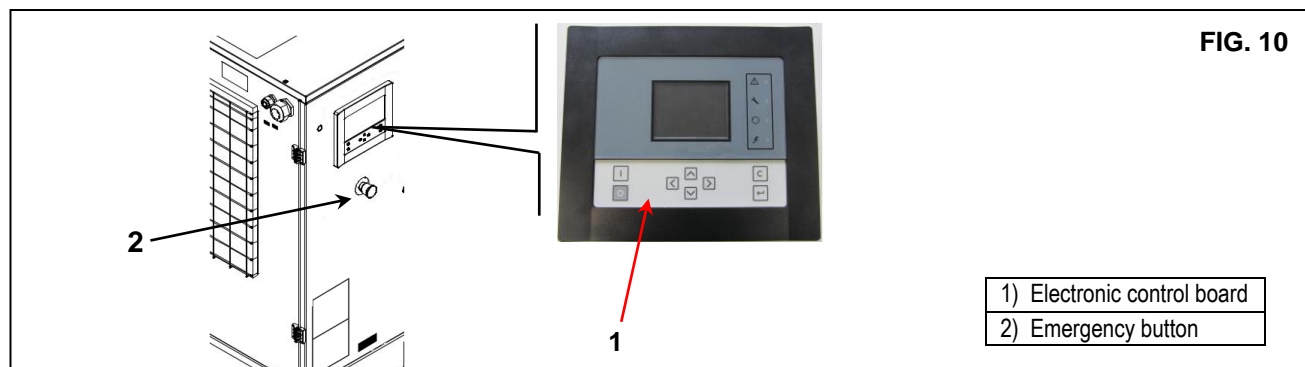

14.3 GRAPHIC CONTROLLER (for variable speed compressors with fixed speed as an optional).

A controller is installed on the electrical cabinet, which performs the following functions:

- Control of compressor and dryer.
- Protection of compressor and dryer.
- Monitoring of components subject to servicing.
- Automatic restart after voltage failure (optional).

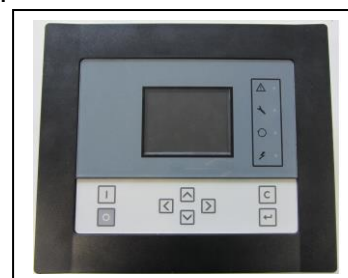
**Automatic control of compressor**

In fixed speed machines, the controller maintains the network pressure within the programmable limits, placing the compressor in unloading and loading mode. In machines with variable speed (inverter), the controller also modifies the motor speed in order to maintain the "Regulation point" pressure. The controller considers a series of programmable settings such as loading and unloading pressures, minimum stop time and maximum motor starts/hours.

The controller shuts down the compressor as soon as possible to reduce energy consumption and automatically restarts it when the network pressure drops. If the set unloading time is too short, the compressor is kept running.

Protection of compressor**Fail stop**

The compressor is stopped and this is shown on the display in the following cases:

- Screw compressor temperature higher than the programmed shutdown value measured by the temperature sensor.
- Screw compressor temperature higher than the programmed shutdown value measured by the thermostats (TSHH11-12).
- Main motor overload.
- Phase sequence relay (fixed speed only).
- Fault in one of sensors (incorrect Pressure or Temperature display).
- Fan motor overload.

The chapter "Fail stop display" explains how the stop is shown on the display, how to identify the type of shutdown and how to resolve the problem.

Alarm warning

It is possible to programme an alarm level lower than the shutdown level.

If any of the measurements exceed the programmed alarm level, an alarm will be shown to inform the operator before the fail stop level is reached. An alarm appears in the following cases:

- High screw compressor temperature
- Dew point temperature too high or too low in case of machines with dryer.

The chapter "alarm display" explains how this is shown on the display, how to identify the type of alarm and how to resolve it.

Service warning

If the service timer exceeds the programmed value, a warning is shown to inform the operator that servicing is needed.

Automatic restart after voltage failure

The controller has an incorporated function to automatically restart the compressor when the power is restored.

The function is not active; contact the customer centre to activate it.



If the controller is set in automatic mode, the compressor automatically restarts when the power is restored.

Control panel

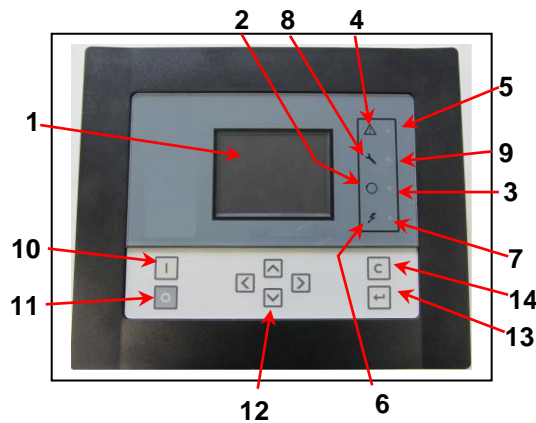



















FIG. 11

Controller function keys

Reference	Name	Function
1	Display	Shows the icons and operating conditions.
2	Automatic operation symbol	
3	LED, automatic operation	Indicates that the regulator is automatically controlling the compressor, which is placed in loading and unloading mode, stopped and restarted based on the consumption of compressed air and the limitations programmed in the regulator.
4	Warning symbol	
5	LED, warning	This turns on when a warning condition occurs.
6	Voltage present symbol	
7	LED, voltage supplied	Indicates the presence of voltage.
8	Service symbol	
9	LED, service	This turns on when servicing is needed.
10	Start Button	This button starts the compressor. The automatic operation LED (3) turns on. The controller is working.
11	Stop Button	This button is used to stop the compressor. The automatic operation LED (3) turns off.
12	Scroll buttons	Use these buttons to scroll through the menu.
13	Enter Button	Use this button to confirm the last operation performed.
14	Esc. Button	Use this button to return to the previous screen or end the current operation.





Icons used

Status icons









Name	Icon	Description
When stopped / When running	 57786F	When the compressor is stopped, the icon is fixed. When the compressor is running, the icon rotates.
Compressor status	 57787F	Motor stopped
	 57788F	Unloading mode
	 57789F	Loading mode
Machine control modes	 57789F Or  59161F	Local start / stop
	 57791F	Remote start / stop
	 57792F	Network control
Automatic restart after voltage failure	 57793F	Automatic restart after voltage failure active
Weekly timer	 57794F	Weekly timer active
Protection functions active	 57795F	Emergency shutdown
	 57796F	Safety shutdown
	 57797F	Alarm
Service	 57798F	Service warning
Main screen display	 82196F	Display icon with rows of numeric values
	 82196F	Chart display icon
General icons	 81105D	No communication/network problem
	 82418D	Remote start / stop

ENGLISH















Input icons

Icon	Description	Icon	Description
 57798F	Pressure	 57801F	Digital input
 57800F	Temperature	 57802F	Special protection

System icons

Icon	Description	Icon	Description
 57803F	Screw compressor (LP, HP, ...)	 57809F	Motor
 57804F	Dryer	 57810F	Expansion module failure
 57805F	Fan	 81105D	Network problem
 57806F	Inverter	 57812F	General alarm

Menu icons

Icon	Description	Icon	Description
 57813F	Input	 57818F	Historical events (saved data)
 57814F	Output	 7819F	Access key / User password
 57812F	Protections (Warnings, shutdowns)	 57792F	Network
 57815F	Counters	 57820F	Regulation point
 82641D	Test	 57867F	Information
 57817F	Regulation (Settings)	 57794F	Weekly timer
 57798F	Service	 82633D	General

Navigation arrows

 57821F	Up	 57822F	Down
--	----	--	------

Main screen

Function: the main screen is automatically displayed when the controller is powered and when any of the keys are pressed. The screen automatically turns off after a few minutes if no keys are pressed.

It is normally possible to choose between 5 different types of main screens:

- 2 Value Lines
- 4 Value Lines
- Chart (High Resolution)
- Chart (Medium Resolution)
- Chart (Low Resolution)

Screen with two and four value lines.

This type of main screen shows the values of 2 or 4 parameters (see Input Menu section).



Typical main screen (2 value lines), fixed speed compressors	Typical main screen (4 value lines), fixed speed compressors
--	--

Text in figure

(1)	Compressor outlet.
(2)	Element outlet.
(3)	Off, Start-up, Load, etc. (the text varies depending on the effective conditions of the compressor).
(4)	Menu.
(5)	Running Hours.
(6)	Load relay (one of the output signals of fixed speed compressors). Flow (compressors with inverter).

Section **A** shows information relative to the operation of the compressor (for example, the working pressure or output temperature of the compressor). On compressors with inverter, the instantaneous air flow is provided as a % of the maximum flow.

Section **B** shows the status icons. This field generally shows the following icons:

- Fixed icons

These icons are always displayed in the main screen and cannot be selected using the cursor, for example, compressor stopped or running, compressor status (running, in unloading mode or motor stopped).

- Optional icons

These icons are only displayed if the corresponding function has been activated (for example weekly timer, automatic restart after voltage failure, etc.):

- Pop-up icons

These icons are displayed in the case of warnings (notifications, shutdowns, service, etc.). To bring up more information about the displayed icons, select the icon using the scroll keys and press the Enter key.

Section **C** is called the status bar. This bar displays the text corresponding to the selected icon.

Section **D** shows the action buttons. These buttons are used to:

- bring up or programme the settings;
- reset a motor overload, a service message or emergency shutdown;
- access all data collected by the regulator.

The function of the buttons depends on the displayed menu. The most common functions are Menu (to access the menu), Modify (to modify the programmable settings) and Reset (to reset a counter or message).

To activate an action button, select the button using the scroll keys and press the Enter key.

To return to the previous menu, press the Escape key.

Chart display

Instead of viewing the values, it is possible to view the chart of one of the input signals (see Input Menu section) based on time.

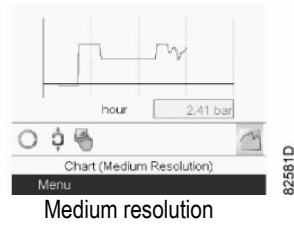
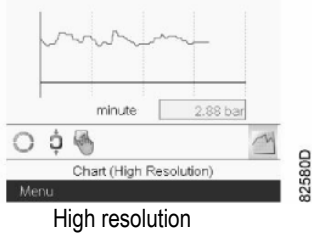

When Chart (High Resolution) is selected, the chart shows the variations of the selected input (in this case pressure) per minute. The immediate value is also displayed. The screen shows the values of the last 4 minutes.

The switching button (icon) to select other screens assumes the appearance of a small chart and is highlighted (active).

When Chart (Medium Resolution) is selected, the chart shows the variations of the selected input per hour. The screen shows the values of the last 4 hours.

When Chart (Low Resolution) is selected, the chart shows the variations of the selected input per day. The screen shows the variations over the last 10 days.

Main screen selection

To move between the various layouts of the screen, select the rightmost icon in the row of command icons (see value lines display icon or chart display icon in the Icons used section) and press the Enter button. A screen will appear similar to the one shown below:

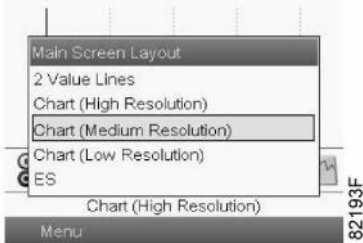

Select the desired icon and press the Enter key. See also Input Menu section.

Menu recall

Description: when the controller is powered, the main screen is automatically displayed (see Main Screen section):



To switch to the Menu screen, select the Menu button (4) using the scroll keys. Press the Enter key to select the menu. The following screen appears:

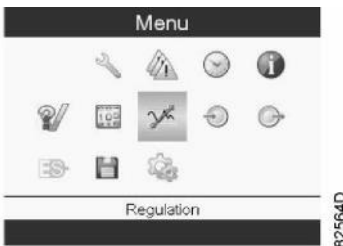

A series of icons are shown on the screen. Each icon represents a menu item. By default, the pressure settings icon (regulation) is selected. The status bar shows the name of the menu corresponding to the selected icon. Use the scroll keys to select an icon. Press the Escape key to return to the main screen.

Alarm display

In case of an alarm, a yellow triangle appears in the bottom part of the display, as shown in the left-hand side figure below:



To identify the type of alarm, highlight the yellow triangle using the scroll buttons. Press Enter and the Protections menu will appear as shown in the right-hand side figure above. Press Enter and the list of active protections in the controller will appear. Use the scroll buttons to check all the protections and the one generating the alarm will be highlighted, such as the one in the figure below:

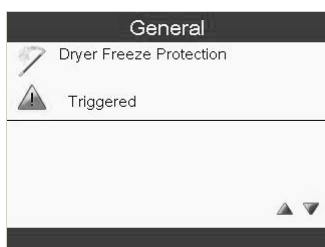

Stop the compressor by pressing button (11) in figure 11 and wait for the compressor to stop. Open the disconnect switch of the compressor's supply line.

ATTENTION:  Before performing any type of servicing, the machine must be stopped, the electrical supply line and compressed air distribution network must be isolated and a check must be made to ensure the machine is not under pressure. Inspect the compressor to identify and eliminate the fault. The warning will disappear once the fault condition has been eliminated.

Shutdown display

In case of a shutdown, a red icon appears in the bottom part of the display, as shown in the left-hand side figure below:

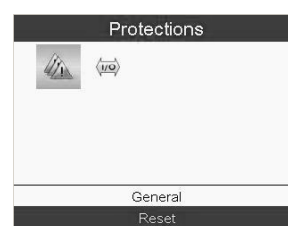

To identify the cause of the shutdown, highlight the red icon (1) using the scroll buttons. Press Enter and the Protections menu will appear as shown in the right-hand side figure above. Press Enter and the list of active protections in the controller will appear. Use the scroll buttons to check all the protections and the one generating the shutdown will be highlighted, such as the one in the figure below:

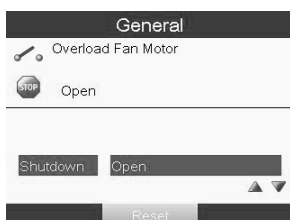

Attention: A "Motor overload" shutdown will appear in the event of a motor overload, incorrect phase sequence (detected by the phase sequence relay), overtemperature detected by the thermostats (TSHH11-12), and if the fan overload protection is triggered. Open the disconnect switch of the compressor's supply line.

ATTENTION:  Before performing any type of servicing, the machine must be stopped, the electrical supply line and compressed air distribution network must be isolated and a check must be made to ensure the machine is not under pressure. Inspect the compressor to identify and eliminate the fault.

ENGLISH

After having eliminated the fault, power and restart the machine.

If the INVERTER ALARM RESET is unsuccessful:

- Disconnect the power supply to the machine for **15min.**
 - After having restored the power supply, **RESET** the **Control Board**.
- If the problem persists, **contact the technical service centre**

Inverter warnings and alarms

Error number	Alarm cod. on GRAPHIC control board	Error text	Warning	Alarm	Trip locked	Cause of problem
2		Error live zero	X	X		The signal on terminal 53 is too low (normal when a machine with STD+ controller is started).
4	16384	Phase loss on supply line	X	X	X	Missing phase on supply line or voltage imbalance too high. Check power supply.
7	2048	DC overvoltage	X	X		The intermediate circuit voltage is over the limit (check supply).
8	1024	DC undervoltage	X	X		The intermediate circuit voltage is below the "low voltage warning" limit (check supply).
9	512	Inverter overload	X	X		Load greater than 100% for too long. Check the compressor mechanics and loading/unloading valve.
10	256	High motor ETR temperature	X	X		The motor is too hot due to the load being greater than 100% for too long. Request assistance from the distributor.
11	128	Motor thermistor disconnected	X	X		The thermistor or thermistor connection are disconnected (if thermistors are included). Request assistance from the distributor.
13	32	Overcurrent	X	X	X	The maximum inverter current limit has been exceeded. Request assistance from the distributor.
14	4	Ground fault		X	X	Discharge from output phases to ground.
16	4096	Short circuit		X	X	Short circuit in motor or on motor terminals.
17	16	No communication (RS 485 port)	X	X		Connection cable or settings
24		Fan Malfunction	X	X		Fan malfunction
30		U phase loss		X	X	U phase of motor does not exist. Check phase.
31		V phase loss		X	X	V phase of motor does not exist. Check phase.
32		W phase loss		X	X	W phase of motor does not exist. Check phase.
36		Voltage drop	X	X		Problem with supply.
38		Internal fault		X	X	Compressor contact service.
44		Ground fault		X	X	Discharge from output phases to ground. Request assistance from the distributor.
47		Control voltage fault	X	X	X	Possible overload of 24V DC supply.
48		VDD1 supply low		X	X	Low control voltage. Compressor contact service.
50÷58		Configuration error		X		Request assistance from the distributor.
59		Current limit	X			The current is higher than the current limit value. Request assistance from the distributor.
60		External interlock		X		The external interlock has been activated. Reset on the compressor control board. If the alarm doesn't reset, request assistance from the distributor.
66		Low heat sink temperature	X			This warning is sent by the temperature sensor in the IGBT module.
69		Temp. power board	X	X	X	The power board temperature sensor is too hot or too cold.
79		Incorrect configuration of power section	X	X		Internal fault. Request assistance from the distributor.
80		Drive initialised		X		All the parameter settings are initialised as settings in the default values of the Inverter. Request assistance from the distributor.
84		Internal error	X	X		Request assistance from the distributor.
85		Button disabled	X			Drive settings.
86		Inverter display (LCP) copy failed	X			Parameters incompatible or firmware version not correct.
87		Auto DC braking	X			Inverter internal limiting.
88		LCP inverter display data incompatible	X			
89		Read-only parameter (not editable)	X			
90		Internal error	X	X		Attempt to update the same parameter simultaneously.

Error number	Alarm cod. on GRAPHIC control board	Error text	Warning	Alarm	Trip locked	Cause of problem
94		Internal error	X	X		Request assistance from the distributor.
120		Internal error	X	X		Request assistance from the distributor.

Inputs menu

Function: allows the effective value of the measured data (analogue inputs) to be viewed, and the status of the digital inputs (for example the emergency stop contact, the motor overload relay, etc.) and allows the selection of the digital input to be shown on the chart in the main screen. Procedure: from the Main screen (see main Screen), move the cursor onto the Menu action button and press the Enter key. Using the scroll keys, move the cursor onto the Inputs icon, as shown in the screen below:

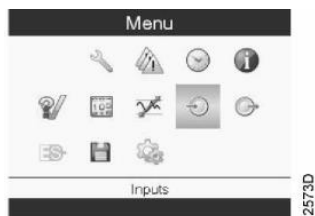

Press the Enter key. A screen will appear similar to the one shown below:

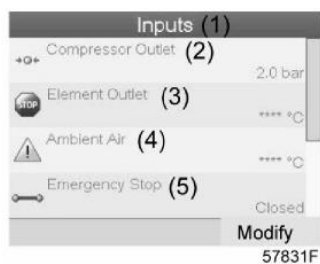

(1)	Inputs
(2)	Compressor outlet
(3)	Element outlet
(4)	Ambient Air
(5)	Emergency shutdown

The screen displays a list of all the inputs with the relative icons and values.

If an input is found in an alarm or stop condition, the original icon is replaced by the respective stop or warning icon (in this specific case, the Stop icon and the Alarm icon shown in the screen above).

A small chart icon shown under a screw compressor in the list indicates that this input signal is shown in the chart, in the main screen. Any analogue input can be selected.

ENGLISH

Outputs menu

Function: brings up information relative to the effective status of certain outputs.

Procedure: from the Main screen (see main Screen), move the cursor onto the Menu action button and press the Enter key. Move the cursor onto the Outputs icon (see below):

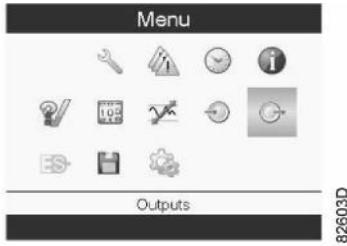

Press the Enter key. A screen will appear similar to the one shown below:



(1)	Outputs
(2)	Fan motor
(3)	Blowoff
(4)	General shutdown
(5)	Automatic Operation

Outputs screen (typical)

The screen displays a list of all the outputs and their relative status (open/closed).

Counters

Function: to view the running hours, the loading running hours, the number of main motor starts, the number of controller running hours and the number of loading cycles.

Procedure: from the Main screen (see main Screen), move the cursor onto the Menu action button and press the Enter key. Using the scroll keys, move the cursor onto the Counters icon (see below):



Press the Enter key. A screen will appear similar to the one shown below:



(1)	Counters
(2)	Running Hours
(3)	Motor Starts
(4)	Load relay
(5)	VSD 1-20 % rpm (the percentage of time during which the motor speed stays between 1 and 20%) (compressors with inverter)

The screen displays the list of all counters and the relative effective values.

Note: the example above refers to an inverter-driven compressor. For a fixed speed compressor, the effective screen will be slightly different.

Control mode selection

Function: to select the Control Mode from among the available modes, specifically Local Control, Remote Control or LAN (Local Area Network) Control.

Procedure: starting from the main screen, make sure the Menu button (1) is selected:



Then using the scroll buttons, move to the status icons and select the regulation icon (2). The icon is active when it is highlighted on a grey background.

Press the Enter button:



There are 2 possibilities:

Local control

LAN (network) control

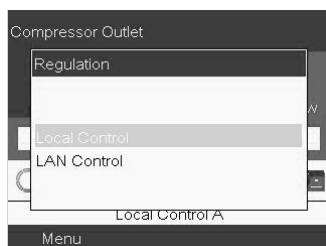

After having selected the requested Regulation Mode, press the Enter key on the controller to confirm the selection. The new setting is now visible on the main screen. See the Icons used section for details of their meaning.

To activate remote control, contact the customer centre.

ENGLISH

Service menu

Function: to reset the service warnings, to check when the next service is due, to check which service plans have been previously carried out, to modify the programmed service intervals.

Procedure: from the Main screen (see main Screen), move the cursor onto the Menu action button and press the Enter key. Using the scroll keys, move the cursor onto the Service icon (see below).



Press the Enter key. A screen will appear similar to the one shown below:

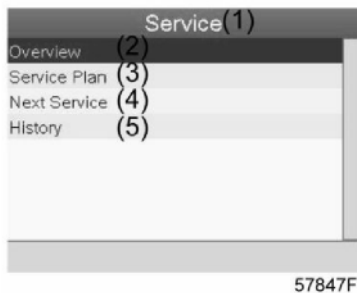

(1)	Service
(2)	Overview
(3)	Service plan
(4)	Next service
(5)	History

Scroll the items to select the desired item and press the Enter key to view the details, as explained above.

Overview

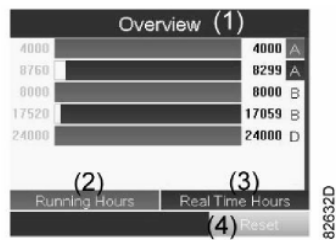

(1)	Overview
(2)	Running Hours
(3)	Real Time Hours
(4)	Reset

Example of service level (A): the digits on the left represent the programmed service intervals. For service interval A, the programmed number of running hours is 4000 hours (top row, green) and the programmed number of real time hours is 8760 hours, which corresponds to one year (second row, blue). This means that the controller sends a service warning every 4000 running hours or every 8760 effective hours, whichever condition occurs first. Note that the real time counter continues to tick over even when the controller is not powered. The digits at the end of the bar represent the number of hours left until the next service. In the example shown, the compressor has just been started, therefore it still has 4000 running hours or 8299 effective hours until the next service.

Service plans

Service operations are grouped (level A, level B, etc.). Each level entails a series of service operations that need to be carried out in accordance with deadlines programmed into the controller.

When the service plan interval is reached, a message is shown on the screen. After having performed the service operations relative to the indicated levels, the timers need to be reset. From the Service menu, select Service Plan (3) and press Enter. The following screen appears:

(2) Level	(3) Running Hours	(4) Real Time
A	4000	8760
B	8000	17520
C		
D	24000	
E	32000	
(5) Modify		

(1)	Service plan
(2)	Level
(3)	Running Hours
(4)	Real Time Hours
(5)	Modify

In the example shown, service level A has been programmed at 4000 running hours, of which 0 hours have passed.

History

The History screen shows a list of all service operations performed in the past, in date order. The topmost date corresponds to the most recent service. To see the details of the service operations performed (that is, the service level, running hours or real time hours), use the scroll keys to select the desired service and press the Enter key.

Regulation menu (Settings)

Function: in fixed speed compressors, it is possible to programme two different pressure bands. From this menu it is also possible to select the active pressure band.

Procedure: from the Main screen (see main Screen), move the cursor onto the Menu action button and press the Enter key. Using the scroll keys, move the cursor onto the Regulation icon (see below):



Press the Enter key. A screen will appear similar to the one shown below:



(1)	Regulation/Settings
(2)	Unloading pressure 1
(3)	Loading pressure 1
(4)	Unloading pressure 2
(5)	Loading pressure 2
(6)	Modify

The screen shows the effective unloading and loading pressure settings for both pressure bands.

To change the settings, move the cursor onto the Modify action button and press the Enter key. The following screen appears:



The first row of the screen is highlighted. Use the scroll keys to highlight the setting to be changed and press the Enter key. The following screen appears:

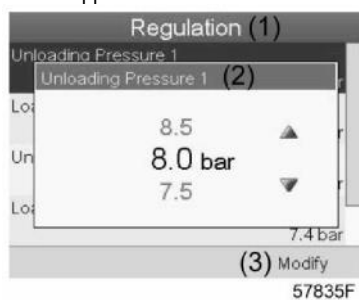

The upper and lower limits of the setting are shown in grey, the current settings are shown in black. Use the scroll key \uparrow or \downarrow to change the settings as needed and press Enter to confirm.

If necessary, change the other settings following the same procedure explained above.

Event history menu

Function: to bring up the data of the last shutdown (safety/emergency).

Procedure: from the Main screen (see main Screen), move the cursor onto the Menu action button and press the Enter key. Using the scroll keys, move the cursor onto the Event History icon (see below)



Press the Enter key. A screen will appear similar to the one shown below:



Example of event history screen

Scroll the rows, which indicate the date and time of the shutdown, and press the Enter key to view the other data relative to the compressor status at the time of the shutdown.

Modification of general settings (Calibrations)

Function: allows the viewing and modification of certain general settings.

Procedure: from the Main screen (see main Screen), move the cursor onto the Menu action button and press the Enter key. Using the scroll keys, move the cursor onto the Settings icon (see below):

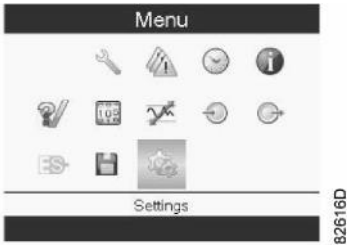

Press the Enter key. A screen will appear similar to the one shown below:

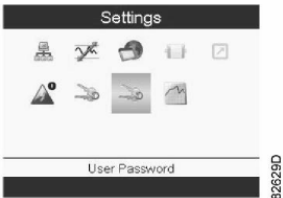

This sub-menu screen also displays certain icons. By default, the User Password icon is selected. The status bar also shows the name of the menu corresponding to the selected icon.

General menu

This menu includes a list of general settings:

- Language
- Time
- Date
- Date format
- Unit of measure

Procedure

Starting from a sub-menu screen (see Modification of general settings), using the scroll keys, move the cursor onto the General icon (see below).

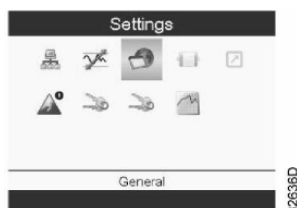

Press the Enter key. A screen will appear similar to the one shown below:

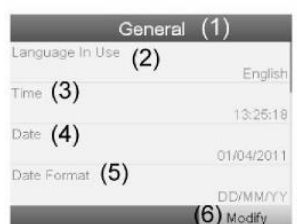

(1)	General
(2)	Language in use
(3)	Time
(4)	Date
(5)	Date format
(6)	Modify

A screen similar to the one shown above appears, with the first item (Language) selected. Use the ↓ key to select the setting to modify and press the Enter key. To confirm the changes, press the Enter key. A pop-up screen appears. Use the ↑ or ↓ key to select the requested parameter and press the Enter key to confirm.

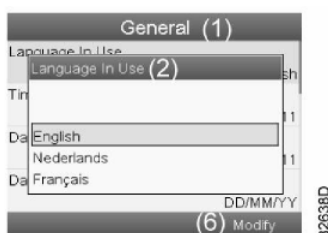

Terminology

Term	Explanation
ARAVF	Automatic restart after voltage failure.
Power return time	The period of time within which the voltage must be restored for automatic restart. It is accessible if automatic restart is active. To activate the automatic restart function, consult the customer centre.
Restart delay	This parameter allows compressor restarts to be programmed in such a way that they don't occur simultaneously after a voltage failure condition (ARAVF active).
Screw compressor outlet	The regulator does not accept conflicting settings. For example, if the alarm level is programmed at 95 °C (203 °F), the minimum shutdown level will become 96 °C (204 °F). The recommended difference between the alarm level and shutdown level is 10 °C (18 °F).
Shutdown delay	This is the period of time during which the signal must persist before the compressor shuts down. Should it be necessary to change this setting to another value, contact the customer centre.
Minimum stop time	When the compressor shuts down, it remains stopped for the minimum stop time regardless of the compressed air distribution network pressure. Contact your supplier if a value less than 20 seconds is required.
Unloading pressure / loading pressure	The regulator does not accept illogical settings. For example, if the programmed unloading pressure is 7.0 bar(e) (101 psi(g)), the maximum loading pressure becomes 6.9 bar(e) (100 psi(g)). The recommended minimum difference between the loading and unloading pressure is 0.6 bar (9 psi(g)).

15.0 ROUTINE MAINTENANCE BY THE USER



BEFORE PERFORMING ANY TYPE OF SERVICING, THE MACHINE MUST BE SHUT DOWN AND ISOLATED FROM THE MAINS POWER AND COMPRESSED AIR DISTRIBUTION NETWORK.

The service operations reported in this chapter can be carried out by the user.

More complex service operations requiring the intervention of professionally qualified personnel are reported in the chapter **GENERAL ROUTINE MAINTENANCE Chap. 21.0**

15.1 GENERAL NOTICES

15.2 MAINTENANCE PROGRAMME

■ **OPERATIONS THAT CAN ALSO BE PERFORMED BY THE USER**

■ ■ **OPERATIONS THAT MUST BE PERFORMED BY TRAINED PERSONNEL; THESE OPERATIONS ARE ILLUSTRATED IN PART "B" OF THIS MANUAL**

These service intervals are recommended for non-dusty and well-ventilated environments.

For particularly dusty environments, the frequency of controls must be doubled.

Every 50 running hours	<ul style="list-style-type: none"> ■ Drain the condensate from the oil catcher ■ Check the oil level <p>IVR only</p> <ul style="list-style-type: none"> ■ Clean the filters of the electrical cabinet
Every 500 hours	<ul style="list-style-type: none"> ■ Tightness of electrical cables (first 500 hours) ■ Clean the air intake filter
Every 2000 hours	<ul style="list-style-type: none"> ■ Replace the intake filter ■ ■ Replace the oil ■ ■ Replace the oil filter ■ ■ Re-tightening of electrical cables in cabinet ■ ■ Temperature test for safety
Every 4000 hours	<ul style="list-style-type: none"> ■ ■ Clean the finned surface of the air-oil cooler ■ ■ Replace the oil separator filter ■ ■ Replace the intake panel filter <p>IVR only</p> <ul style="list-style-type: none"> ■ Replace the air intake filters of the electrical cabinet ■ ■ Greasing of electric motor bearings
Every 8000 hours	<ul style="list-style-type: none"> ■ ■ Change check valve ■ ■ Intake valve service kit ■ ■ Servicing of oil return valve and inspection of oil tubes ■ ■ Minimum pressure valve and thermostatic valve service kit <p>IVR only</p> <ul style="list-style-type: none"> ■ ■ Visual inspection of elastic element of motor-compressor coupling
Every 24000 hours	<ul style="list-style-type: none"> ■ ■ Pump revision kit ■ ■ Motor bearing service kit

Oil specifications:

It is highly recommended to use the manufacturer's original lubricants. These are the result of years of industry experience and research.

See the Routine maintenance programme section for recommended replacement intervals and consult the list of spare parts for information on the part number.



DO NOT MIX LUBRICANTS OF DIFFERENT BRANDS OR DIFFERENT TYPES INSOFAR AS THEY MAY NOT BE COMPATIBLE AND OIL MIXES MAY HAVE INFERIOR PROPERTIES.

15.3 DRAINAGE OF CONDENSATE FROM OIL TANK

If the compressor work cycle involves extended periods of downtime with cooling of the machine, a certain quantity of water condensate will accumulate in the oil tank. This occurs, for example, during night-time or weekend shutdowns.

The condensate must be drained every 50 hours or every week. This operation can only be performed with the machine cold, that is, it must have been off for at least 8 hours.



BEFORE DRAINING THE CONDENSATE, THE MACHINE MUST BE SHUT DOWN AND ISOLATED FROM THE POWER MAINS.

Proceed as follows:

- Turn off the machine using button Ref. 1 Fig. 12: this way, the machine will stop after the unloading run time.
- Open the power disconnect switch Ref. 3 (for screw compressor) Fig. 12.

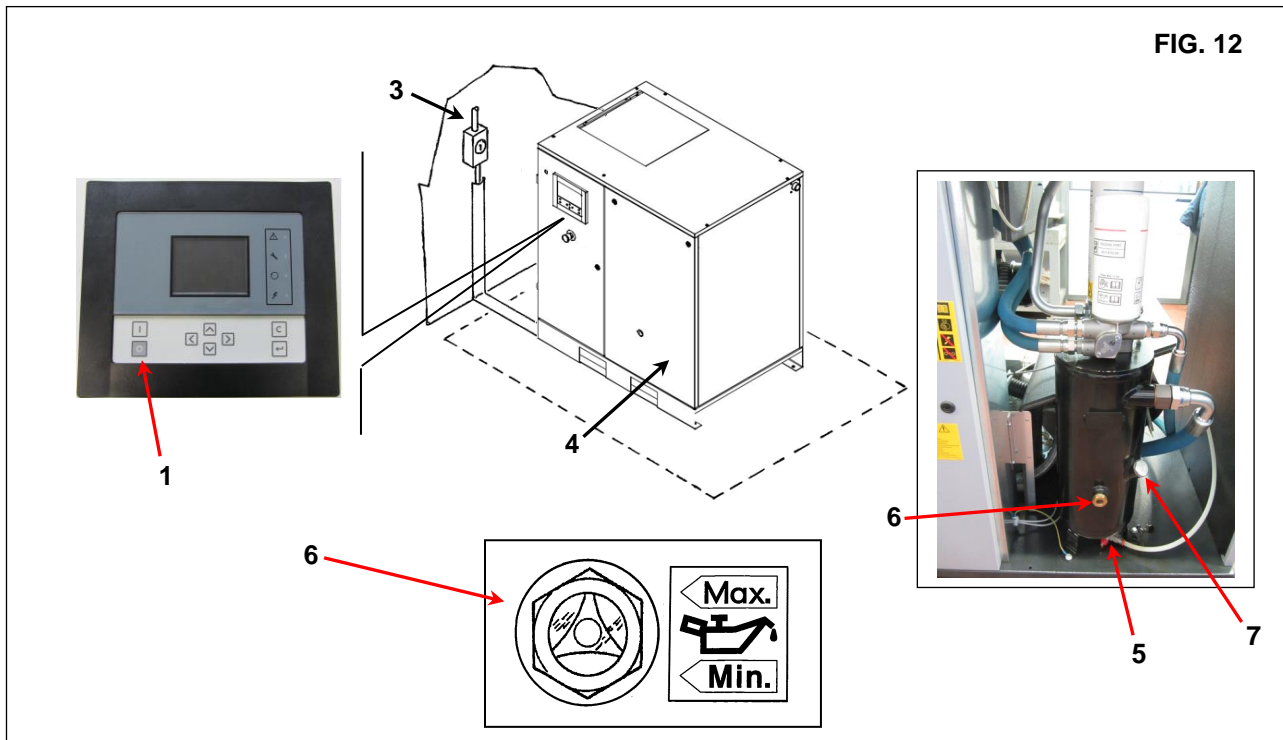

- Wait for the machine to cool
- Open the panel Ref. 4 Fig. 12 using the supplied key.
- SLOWLY open the tap Ref. 5 Fig. 12 and drain the condensate.
- When the first traces of oil appear, close the tap.



CONDENSATE MUST BE DISPOSED OF IN ACCORDANCE WITH LOCAL REGULATIONS IN FORCE

- Check the oil level using the tell-tale Ref. 6 Fig. 12.
- If the oil level is below the minimum, top it up as described in point 15.4.

15.4 OIL LEVEL CONTROL AND TOP-UP

- Turn off the machine using button Ref. 1 Fig. 12: this way, the machine will stop after the unloading run time.
- Open the power disconnect switch Ref. 3 (for screw compressor) Fig. 12.
- Wait 5 minutes for the foam to settle in the oil tank.
- Check the oil level using the tell-tale Ref. 6 Fig. 12.
- If the oil level is below the minimum, top it up.

USE THE SAME TYPE OF OIL AS THAT PRESENT IN THE MACHINE, DO NOT MIX DIFFERENT TYPES OF OIL



BEFORE PERFORMING ANY OPERATIONS ON THE MACHINE, CHECK THAT IT HAS BEEN ISOLATED FROM THE ELECTRICAL POWER SUPPLY.

- Open the front panel Ref. 4 Fig. 12 with the special key
- Slowly open the oil cap Ref. 7 Fig. 12.
- Top up until the maximum level Ref. 6 Fig. 12 with the same type of oil as that in the compressor.
- Close the tank cap Ref. 7 Fig. 12.
- Close the panel Ref. 4 Fig. 12.

OIL LEVEL CHECK

Machine running:

- the foam level is roughly in the middle of the sight glass.

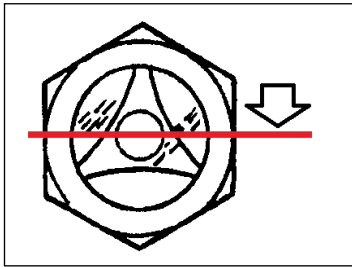

Machine stopped for a few minutes:

- As soon as the foam disappears, the sight glass must be almost completely covered.

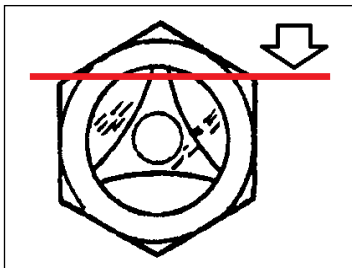

ATTENTION:

- Do not check the oil level on a machine stopped for more than 10 minutes.
- Do not add any extra oil.



BEFORE PERFORMING ANY TYPE OF SERVICING, THE MACHINE MUST BE SHUT DOWN AND ISOLATED FROM THE MAINS POWER AND COMPRESSED AIR DISTRIBUTION NETWORK.

15.5 ELECTRICAL CABINET FILTER CLEANING (IVR only)

- Turn off the machine using button Ref. 1 Fig. 13: this way, the machine will stop after the unloading run time.
- Open the power disconnect switch Ref. 3 (for screw compressor) Fig.13.
- Remove the electrical cabinet filters Ref. 4 Fig. 13.
- Clean the electrical cabinet filters with a blast of air or wash with water, **Do not use solvents**
- After this operation, remount the filters Ref. 4 Fig. 13.

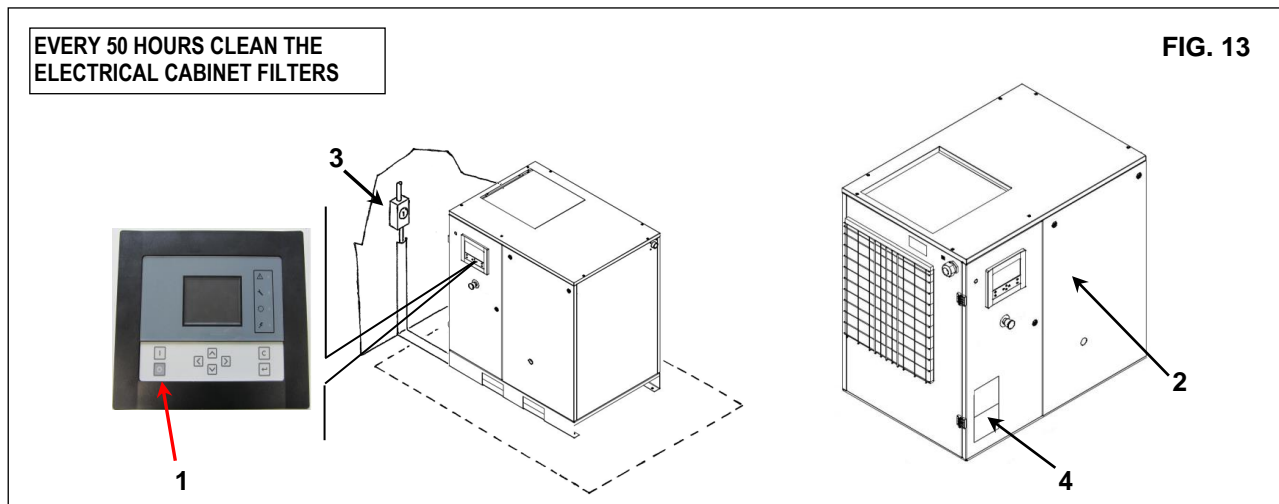

- AIR INTAKE PANEL FILTER CLEANING

- Turn off the machine using button Ref. 1 Fig. 13: this way, the machine will stop after the unloading run time.
- Open the power disconnect switch Ref. 3 Fig. 13.
- Remove the air intake panel filter Ref. 2 Fig. 14.
- Clean the panel filter with a blast of air or wash with water, **Do not use solvents**
- After this operation, remount the panel filter Ref. 2 Fig. 14.

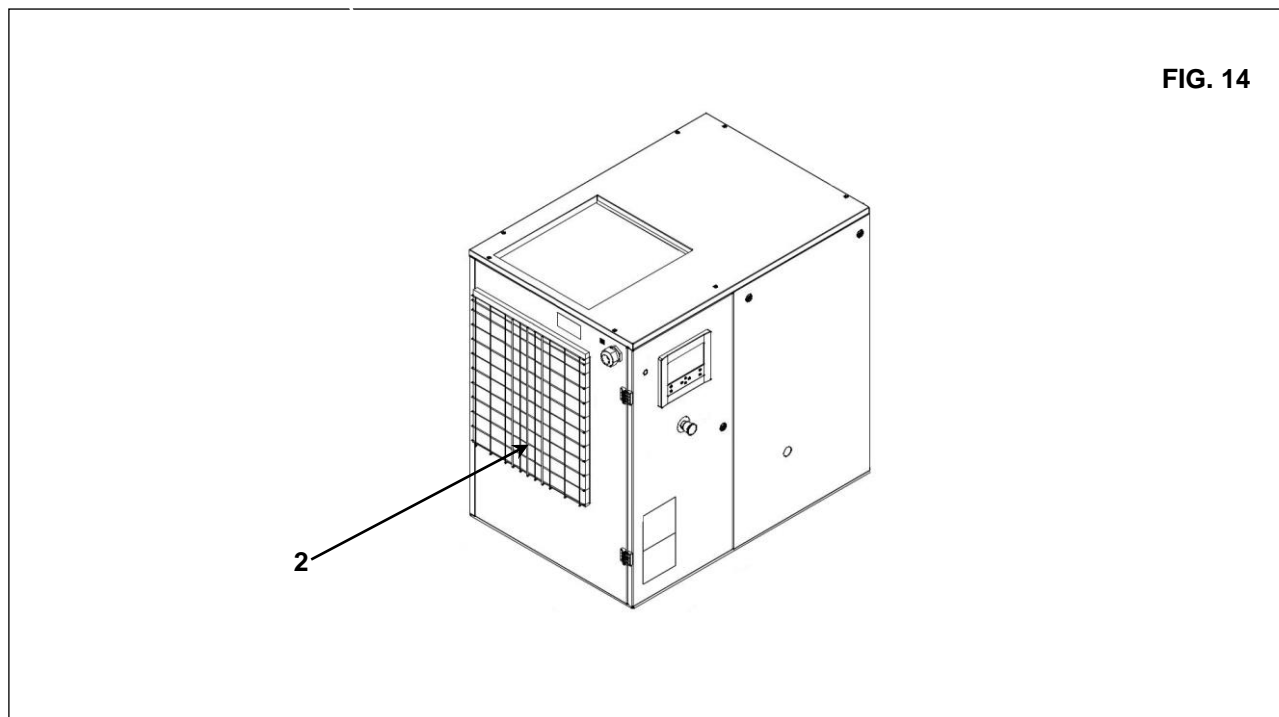



BEFORE PERFORMING ANY TYPE OF SERVICING, THE MACHINE MUST BE SHUT DOWN AND ISOLATED FROM THE MAINS POWER AND COMPRESSED AIR DISTRIBUTION NETWORK.

15.6 INTAKE FILTER CLEANING OR FILTER REPLACEMENT

- Turn off the machine using button Ref. 1 Fig. 13: this way, the machine will stop after the unloading run time.
- Open the power disconnect switch Ref. 3 (for screw compressor) Fig. 13.



HOT INTERNAL PARTS

- Open the panel Ref. 2 Fig. 13.
- Remove the filter cover Ref. 7 Fig. 15.
- Remove the filter element Ref. 8 Fig. 15.



DO NOT ALLOW FOREIGN BODIES TO FALL INTO THE INTAKE MANIFOLD

- Clean the filter element with a blast of air from the inside out, **DO NOT USE WATER OR SOLVENTS**, or: grab a new filter.
- Clean the filter support disc with a clean cloth.
- Mount the filter element and cover.
- If necessary, dispose of the old filter element in accordance with local regulations in force.
- Close the panel Ref. 2 Fig. 13.

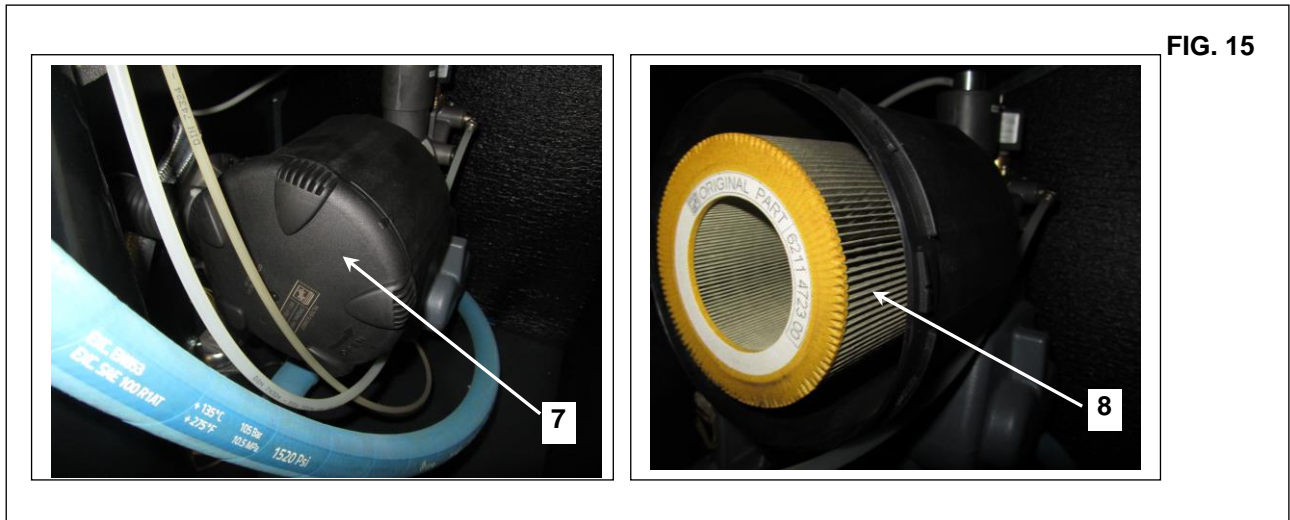

16.0 STORAGE

If the machine is to remain inactive for long periods:

- Turn off the machine using button Ref. 3 Fig. 16: this way, the machine will stop after the unloading run time.
- Close the tap Ref. 1 Fig. 16 (machine with/without tank).
- Disconnect the power using the disconnect switch Ref. 4 (for screw compressor) Fig. 16.

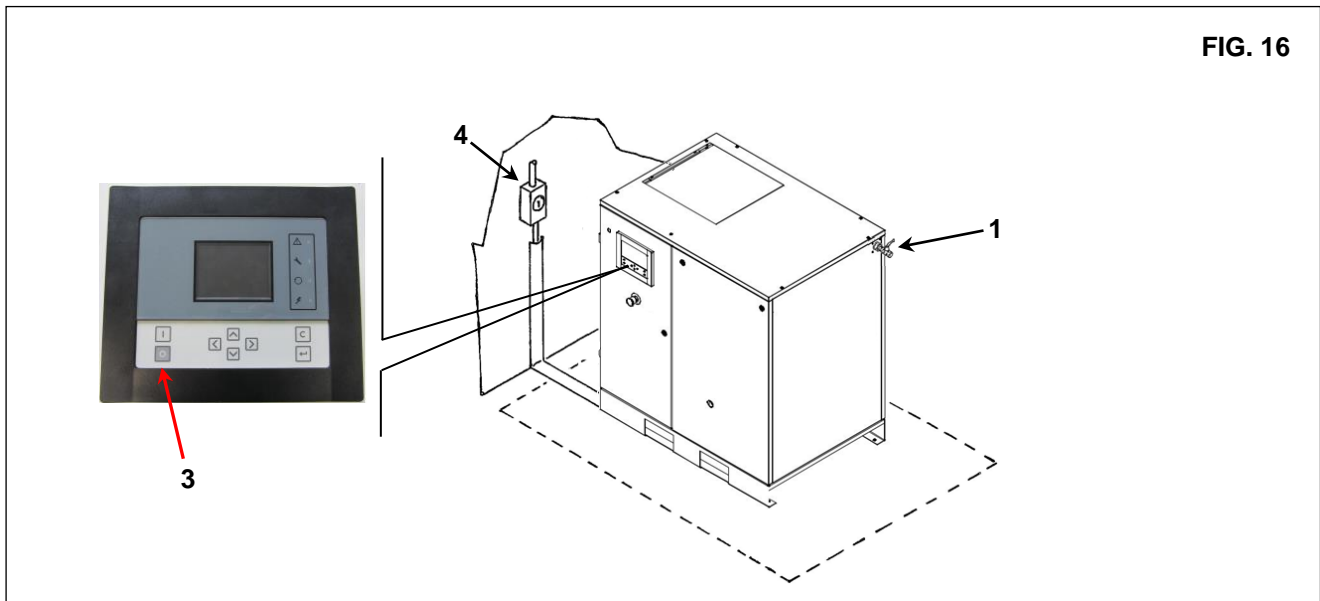

FIG. 16

During downtime, the machine must be protected against atmospheric agents, dust and humidity, which may damage the motor and electrical system. Moreover, the compressor must be placed into operation once per month. For the subsequent start-up, consult the manufacturer's technical service centre.

17.0 DISMANTLING THE COMPRESSOR UNIT

If the machine is dismantled, it must be separated into similar parts for disposal in accordance with local regulations in force.



IT IS RECOMMENDED TO COMPLY WITH REGULATIONS IN FORCE FOR THE DISPOSAL OF USED OIL AND OTHER POLLUTING MATERIALS SUCH AS THERMAL INSULATING SOUNDPROOF FOAM, ETC.

18.0 SPARE PARTS LIST FOR ROUTINE MAINTENANCE

Ref	NAME	Qty.	Code	HP 20 kW 15	HP 25 kW 18.5	HP 30 kW 22
1	Air/oil separator filter	1	6221 3724 50	■	■	
1	Air/oil separator filter	1	6221 3725 50			■
2	Oil filter	1	6211 4722 50	■	■	■
3	Intake filter	1	6211 4723 50	■	■	■
4	Electrical cabinet filters (IVR only)	2	1089 9556 70	■	■	■
5	Air intake panel filter	1	2204 1213 01	■	■	■
	Motor bearings tube (IVR only)	4	1630 2023 00	■	■	■

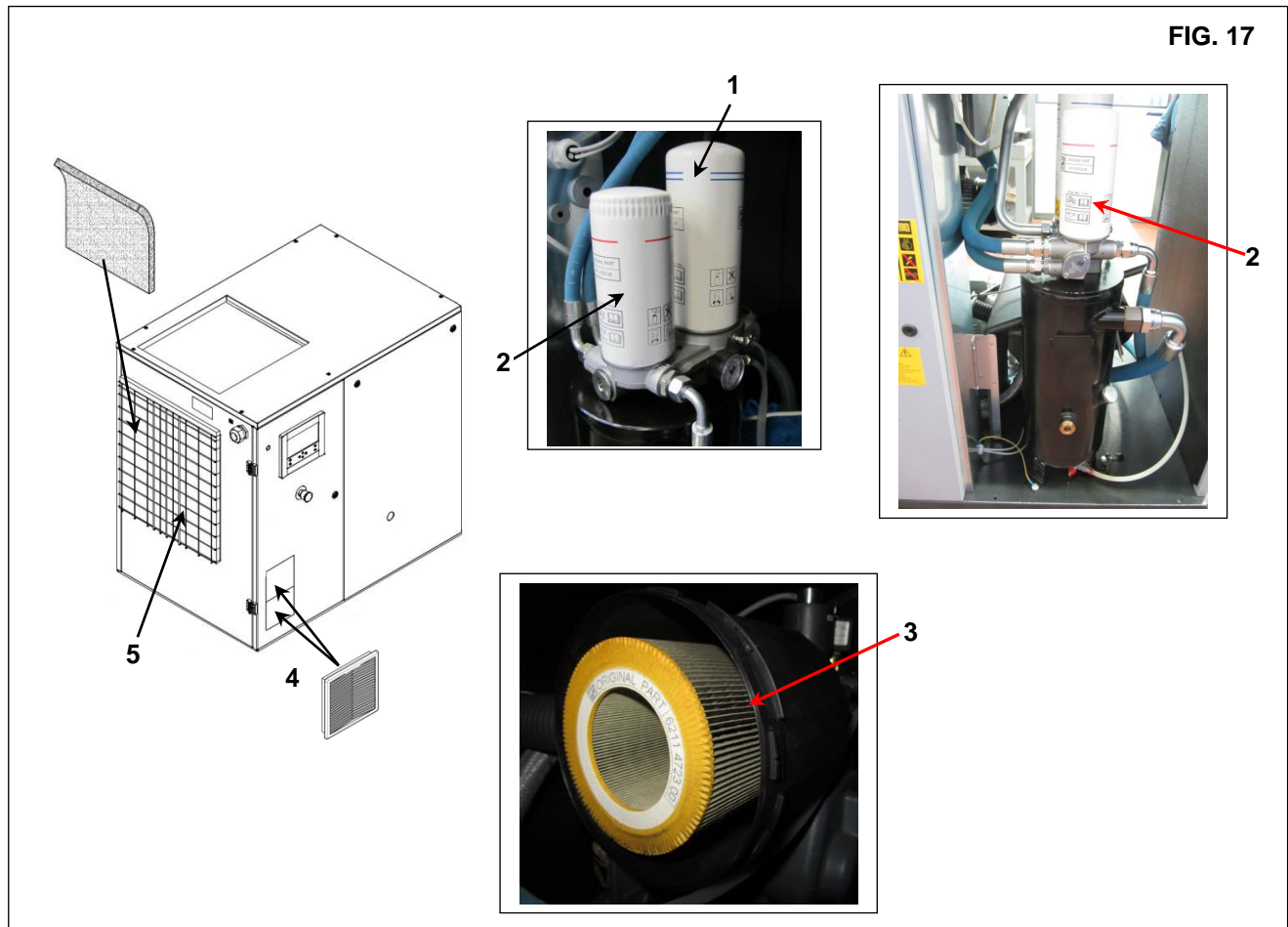

19.0 TROUBLESHOOTING AND IMMEDIATE ACTIONS

N.B. OPERATIONS SHOWN WITH ■ ■ MUST BE PERFORMED BY PROFESSIONALLY QUALIFIED PERSONNEL AUTHORISED BY THE MANUFACTURER.



ALL WORKS MUST BE PERFORMED BY PROFESSIONALLY QUALIFIED PERSONNEL. THE MACHINE MUST BE SHUT DOWN AND ISOLATED FROM THE MAINS POWER AND COMPRESSED AIR DISTRIBUTION NETWORK BEFORE ALL SERVICING OPERATIONS.

19.1 TROUBLESHOOTING AND IMMEDIATE ACTIONS FOR SCREW COMPRESSOR

PROBLEM FOUND	POSSIBLE CAUSES	OBSERVATIONS
1) The machine won't start	1A - no electrical supply 1B - the transformer protection has tripped	- check the electrical power line Chap. 12.2 - replace the fuses
2) The machine won't start, the tell-tale (Ref. 5 Fig.11) is flashing. The intermittent pictogram appears (Fail stop icon)	2A - phases inverted 2B - the main motor thermal relay protection has tripped 2C - Screw compressor thermostat tripped	- check phase sequence - check for any motor faults - ambient temperature too high; improve ventilation in compressor room Chap. 9.2
3) The machine won't start, the tell-tale (Ref. 5 Fig.11) is flashing. The intermittent pictogram appears (Fail stop icon)	3A - the oil temperature protection has tripped	- ambient temperature too high; improve ventilation in compressor room Chap. 9.2 ■ ■ - cooler radiator dirty; clean the radiator - oil level too low; top up the oil tank
4) The compressor doesn't reach the working pressure	4A - the compressed air consumption is too high 4B - the loading/unloading solenoid valve remains closed.	■ ■ check the electrical system
5) Excessive oil consumption	5A - worn oil separator filter - oil level too high	■ ■ - replace the oil separator filter Chap. 23

PART "B"



THIS PART "B" OF THE INSTRUCTION MANUAL IS RESERVED TO PROFESSIONALLY QUALIFIED PERSONNEL, AUTHORISED BY THE MANUFACTURER.

IVR MODELS: THE CAPACITORS INSIDE THE INVERTER MAY REMAIN LIVE FOR 15 MINUTES (VARIABLE SPEED) AFTER THE MACHINE HAS BEEN DISCONNECTED FROM THE MAINS POWER.

WAIT AT LEAST 15 MINUTES (VARIABLE SPEED) AFTER ISOLATING THE SUPPLY VOLTAGE BEFORE PERFORMING SERVICING OPERATIONS OR REPAIRS TO AVOID THE RISK OF DEATH OR SERIOUS INJURY.

20.0 START-UP



BEFORE PERFORMING ANY OPERATIONS ON THE MACHINE, CHECK THAT IT HAS BEEN ISOLATED FROM THE ELECTRICAL POWER SUPPLY

20.1 PREPARATION FOR START-UP

After having made all the checks as indicated in Chap. 12.0 (installation) follow the instructions

20.2 PRELIMINARY CHECKS

Check the oil level Ref. 1 Fig. 18 (only with the machine warmed up), the machine is supplied with a full tank of oil; if the oil level is incorrect, top it up using the same oil as the original type (See chap. 15.4). If the period of time between factory commissioning and the installation date is greater than 3 months, re-lubricate the screw unit before starting it up, following the procedure below:

- Remove the intake filter cover Ref. 2 Fig. 18
- Remove the filter element Ref. 3 Fig. 18
- Pour some oil into the intake unit
- Remount the filter element Ref. 3 Fig. 18
- Remount the intake filter cover Ref. 2 Fig. 18

If the period of time between factory commissioning and the installation date is greater than 6 months, consult the manufacturer's service centre.

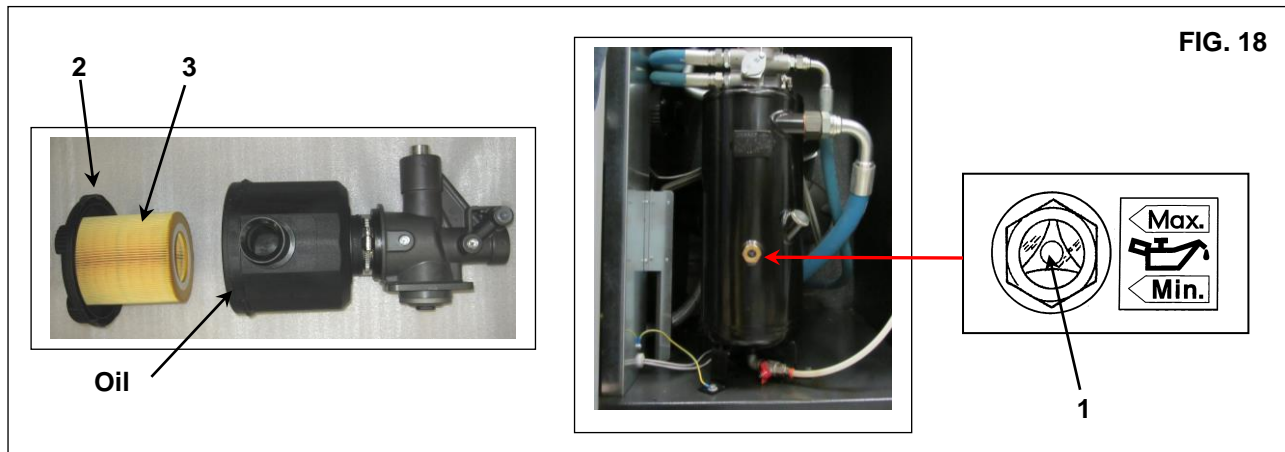

20.3 CHECKING THE DIRECTION OF ROTATION

- Check that all fixed protections are in their proper place.
- Power the control panel using the line switch Ref. 1 Fig. 19.
- Open the rear panel Ref. 7 Fig. 19.
- Check that there are no alarm signals on the control board.
- Check the direction of rotation (as per the arrow on the coupling casing or on the motor Ref. 3 Fig. 19) by pressing the “Run” button Ref. 2 Fig. 19 and the emergency stop button Ref. 4 Fig. 19 immediately afterwards. If the direction is incorrect, invert the two electrical connection wires (phases). If the direction of rotation is correct the oil level Ref. 5 Fig. 19 should drop 4 – 5 seconds after start-up. Moreover, it is very important to check the direction of rotation of the fan (indicated by the arrow on the latter). Ref. 6 Fig. 19.



ALL OPERATIONS ON THE ELECTRICAL SYSTEM, EVEN IF MINOR, MUST BE PERFORMED BY PROFESSIONALLY QUALIFIED PERSONNEL

- It is recommended not to intervene on the machine’s electrical cabinet.

IF ALL THE PROVISIONS REPORTED IN THIS MANUAL HAVE BEEN SATISFIED, IT IS POSSIBLE TO PROCEED WITH START-UP



ATTENTION: AFTER EACH STOP, WAIT AT LEAST 20 SECONDS BEFORE RESTARTING THE MACHINE

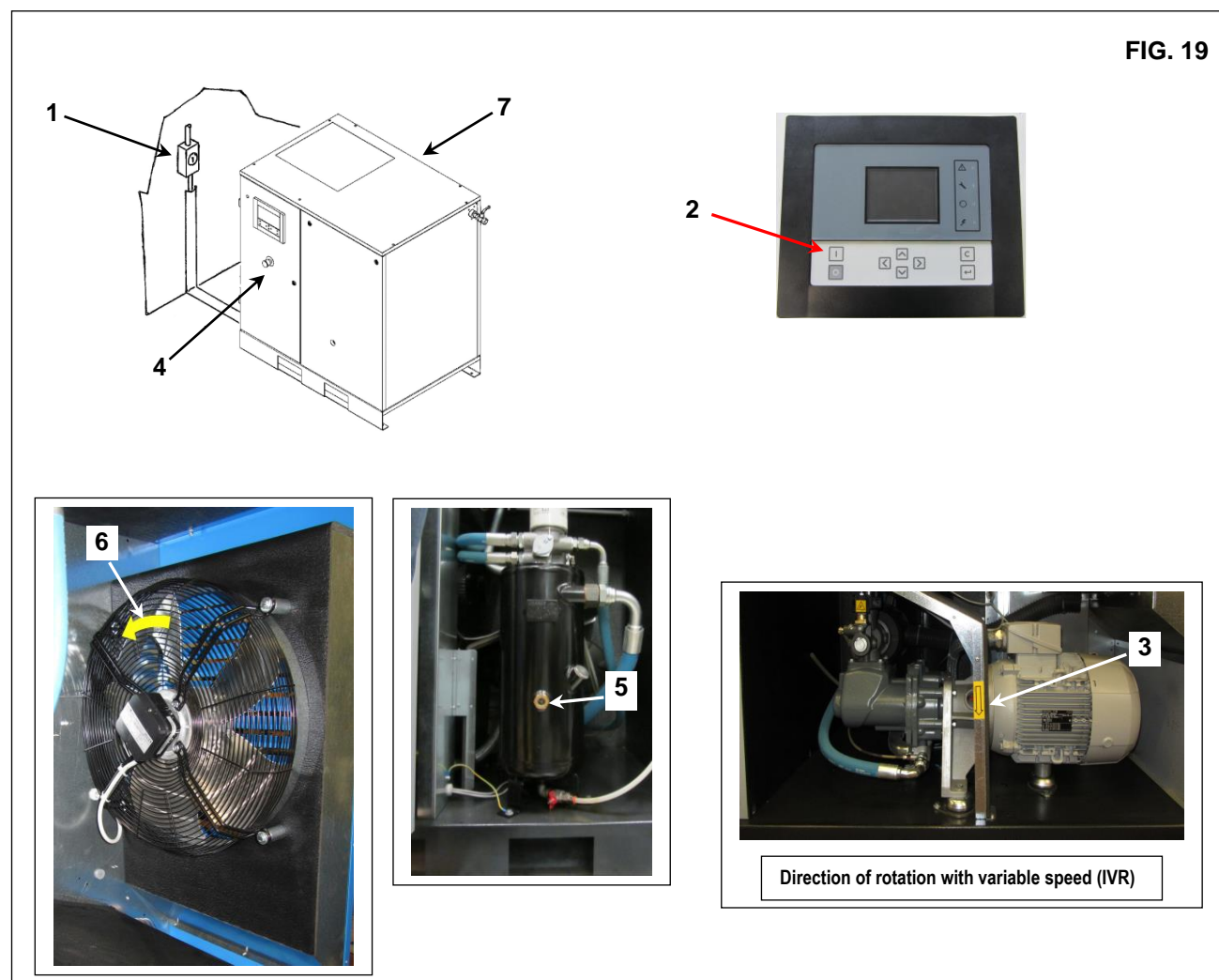

21.0 GENERAL ROUTINE MAINTENANCE (REQUIRES TRAINED PERSONNEL)



BEFORE PERFORMING ANY TYPE OF SERVICING, THE MACHINE MUST BE SHUT DOWN AND ISOLATED FROM THE MAINS POWER AND COMPRESSED AIR DISTRIBUTION NETWORK.

MAINTENANCE PROGRAMME

These service intervals are recommended for non-dusty and well-ventilated environments. For particularly dusty environments, the frequency of controls must be doubled

Every 50 running hours	<ul style="list-style-type: none"> ■ Drain the condensate from the oil catcher ■ Check the oil level <p>IVR only</p> <ul style="list-style-type: none"> ■ Clean the filters of the electrical cabinet
Every 500 hours	<ul style="list-style-type: none"> ■ Tightness of electrical cables (first 500 hours) ■ Clean the air intake filter
Every 2000 hours	<ul style="list-style-type: none"> ■ Replace the intake filter ■ ■ Replace the oil ■ ■ Replace the oil filter ■ ■ Re-tightening of electrical cables in cabinet ■ ■ Temperature test for safety
Every 4000 hours	<ul style="list-style-type: none"> ■ ■ Clean the finned surface of the air-oil cooler ■ ■ Replace the oil separator filter ■ ■ Replace the intake panel filter <p>IVR only</p> <ul style="list-style-type: none"> ■ Replace the air intake filters of the electrical cabinet ■ ■ Greasing of electric motor bearings
Every 8000 hours	<ul style="list-style-type: none"> ■ ■ Change check valve ■ ■ Intake valve service kit ■ ■ Servicing of oil return valve and inspection of oil tubes ■ ■ Minimum pressure valve and thermostatic valve service kit <p>IVR only</p> <ul style="list-style-type: none"> ■ ■ Visual inspection of elastic element of motor-compressor coupling
Every 24000 hours	<ul style="list-style-type: none"> ■ ■ Pump revision kit ■ ■ Motor bearing service kit

N.B. OPERATIONS SHOWN WITH ■ ARE DESCRIBED IN PART "A" OF THIS MANUAL IN CHAP. 15.2

22.0 OIL REPLACEMENT

BEFORE PERFORMING ANY TYPE OF SERVICING, THE MACHINE MUST BE SHUT DOWN AND ISOLATED FROM THE MAINS POWER AND COMPRESSED AIR DISTRIBUTION NETWORK.

Oil replacement is an important operation for the compressor: if bearing lubrication is inefficient, the service life of the compressor will be reduced.

The oil must be replaced with the machine warmed up, that is, as soon as it is stopped.

Therefore, it is recommended to strictly follow the suggestions reported below.

After draining the used oil from the machine through the tap Ref. 2 Fig. 20

- Pour the oil into the catcher Ref. 1 Fig. 20 until the maximum level (See Chap. 15.4).

- Pour a bit of oil into the intake unit Ref. 3 Fig. 20

- Start the compressor.

- After about 1 minute turn off the machine by pressing the "STOP" button (Ref. 4 Fig. 20) after the unloading run time the machine will turn off.

- **PROCEED AS DESCRIBED IN CHAPTER 15.4**

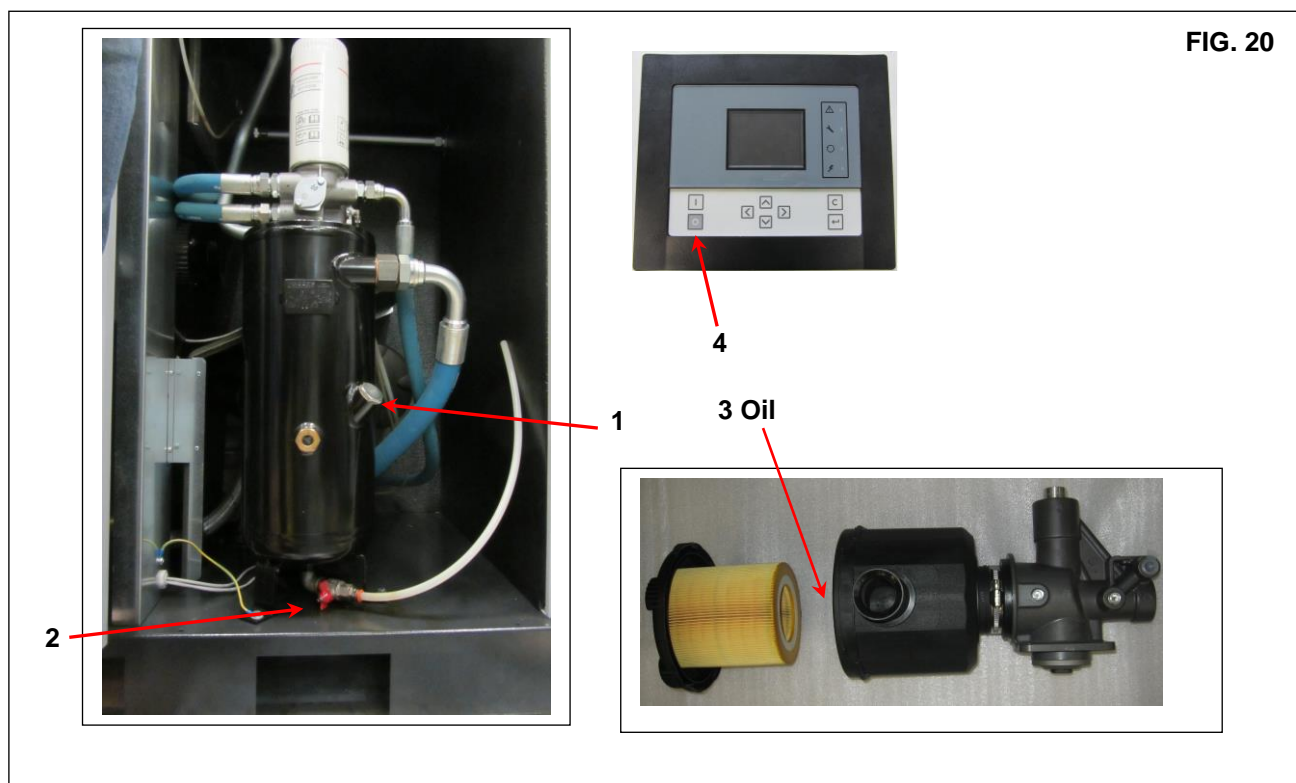
FIG. 20

USED OIL MUST BE DISPOSED OF IN ACCORDANCE WITH REGULATIONS IN FORCE

NOTES ON LUBRICANTS

The machine is supplied already filled with oil.

Prolonged use of the lubricant beyond the prescribed service period may entail the risk of fire.

In case of use at high temperatures or particularly heavy duty service, it is recommended to change the oil at more regular intervals than those prescribed in the maintenance table.

Oil specifications:

It is highly recommended to use the manufacturer's original lubricants. These are the result of years of industry experience and research. See the Routine maintenance programme section for recommended replacement intervals and consult the list of spare parts for information on the part number.

DO NOT TOP UP WITH DIFFERENT OILS



DO NOT MIX LUBRICANTS OF DIFFERENT BRANDS OR DIFFERENT TYPES INsofar AS THEY MAY NOT BE COMPATIBLE AND OIL MIXES MAY HAVE INFERIOR PROPERTIES.

23.0 REPLACE THE OIL SEPARATOR FILTER AND THE OIL FILTER



BEFORE PERFORMING ANY TYPE OF SERVICING, THE MACHINE MUST BE SHUT DOWN AND ISOLATED FROM THE MAINS POWER AND COMPRESSED AIR DISTRIBUTION NETWORK. CHECK THAT THE MACHINE IS NOT UNDER PRESSURE.

OIL FILTER AND OIL SEPARATOR FILTER REPLACEMENT

- Shut down the machine using the button Ref. 2 Fig. 21: in this way, the machine will stop after the unloading run time of about 30 seconds.
NB: The internal pressure is automatically discharged after a delay period of about 60 seconds from the complete shutdown of the machine
- Open the power disconnect switch Ref. 3 (for screw compressor) Fig. 21.
- Close the tap Ref. 5 Fig. 21 (machine with and without tank).
- **Depressurise the compressor by unscrewing the cap of the filling inlet Ref.1 by one turn so as to discharge any residual pressure in the system.**
- Replace the oil filter Ref. 6 and the oil separator filter Ref. 7 Fig. 21
- Lubricate the filter gasket with a bit of oil before remounting it.
- The filters must be tightened by hand.
- **fully screw in the cap of the filling inlet Ref.1 before restarting the machine.**

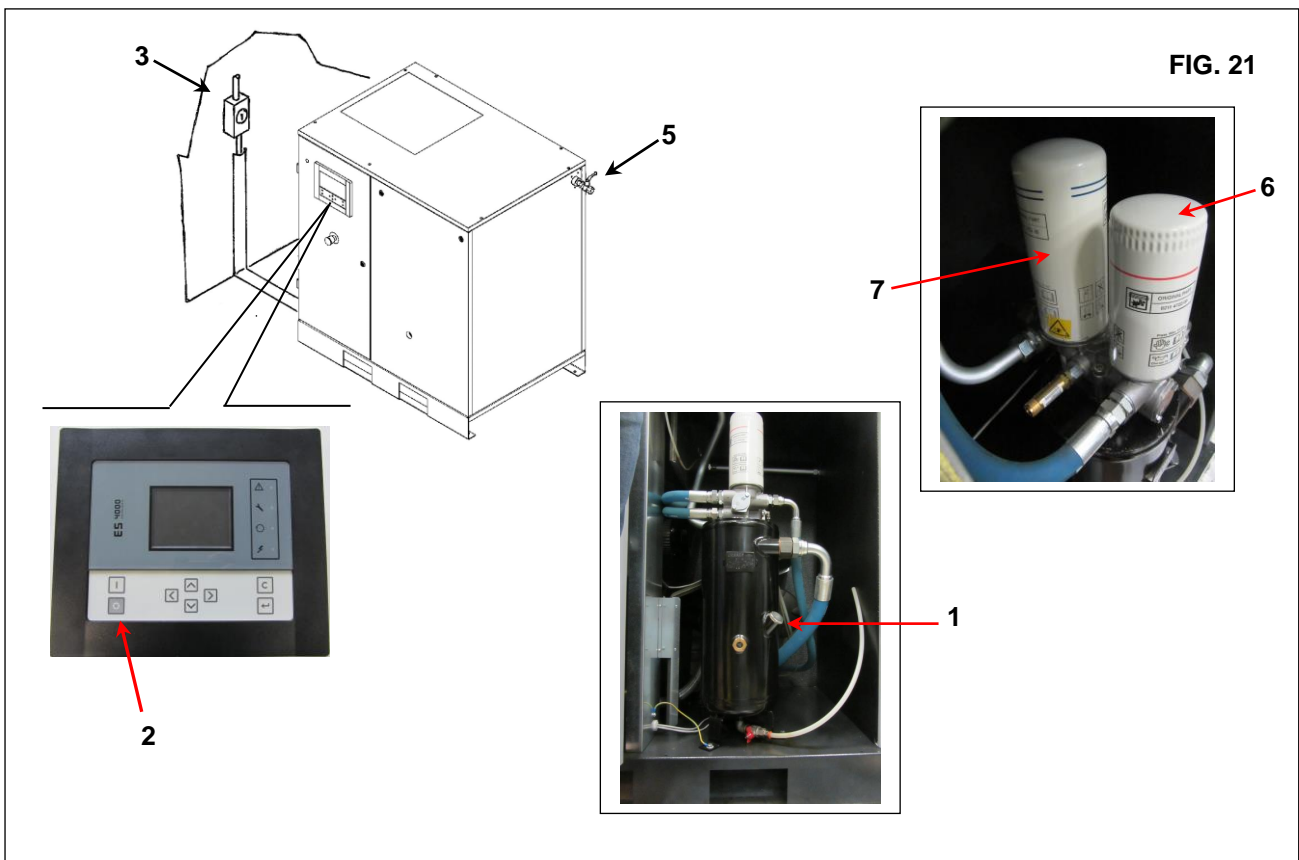

24.0 GRAPHIC CONTROLLER; ELECTRIC MOTOR BEARINGS GREASING (For variable speed only)



BEFORE PERFORMING ANY TYPE OF SERVICING, THE MACHINE MUST BE SHUT DOWN AND ISOLATED FROM THE MAINS POWER AND COMPRESSED AIR DISTRIBUTION NETWORK, AND CHECK THAT THE MACHINE IS NOT UNDER PRESSURE.

- Remove the panel (fixed protection) Ref. 1 Fig. 22
- Remove the grease nipples Ref. 2 and 3 Fig. 22
- Screw the grease tube onto the motor thread.
- Inject the contents of the two tubes for each bearing and screw the grease nipples back on.
- Close the panel (fixed protection) Ref. 1 Fig. 22

Proceed as follows:

- Restore the power supply
- Activate the lubrication programme from the MK5 menu:

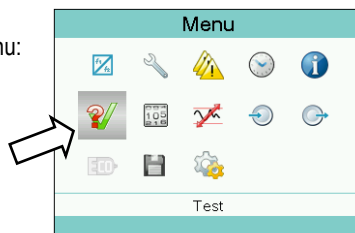

- Select the lubrication function (password **1807**).

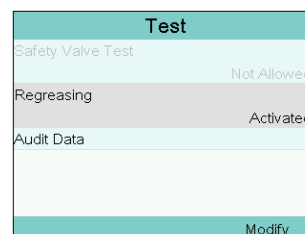
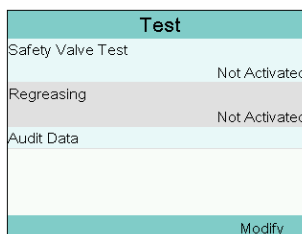

- Go back to the main menu and press **“START”** (Ref. 4 Fig. 22).
- The compressor will run the lubrication programme: in unloading mode for **(15 minutes at 1700 rpm)**.

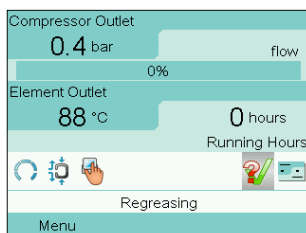

- From the lubrication menu, the operator can check the remaining time.

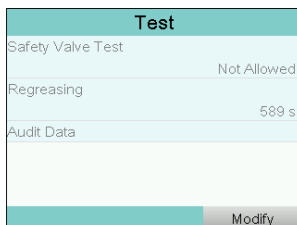

N.B. During lubrication it is not possible to stop the machine using the **STOP button Ref. (5 Fig. 22)**. In any case, in the event of an **EMERGENCY** the operator can stop the compressor by pressing the emergency button. Once normal conditions have been restored, by pressing **START** (Ref. 4 Fig. 22) the compressor will resume lubrication for the remaining time. At the end of the lubrication cycle, the standard operating conditions will therefore be automatically restored.

IVR ONLY
(variable speed)

FIG. 22

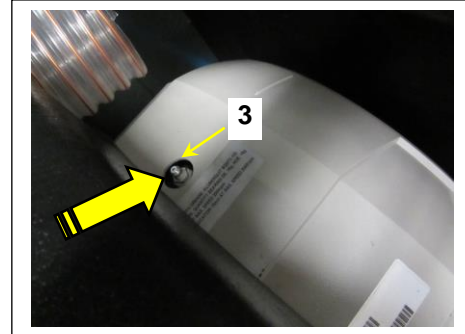
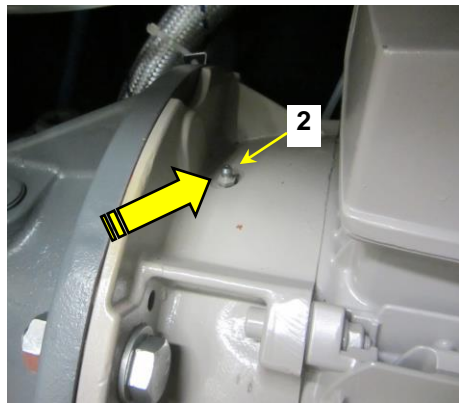
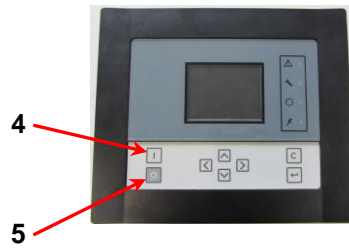
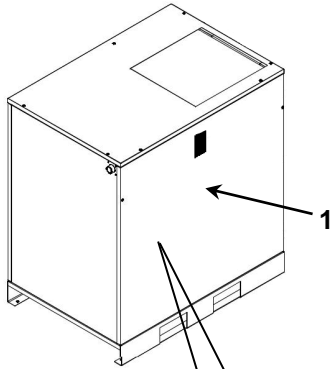

Grease cod. 1630 2023 00			
	(Ref. 2)	(Ref. 3)	
Motor (IVR)	■ (2 PC)	■ (2 PC)	

25.0 OLEO-PNEUMATIC DIAGRAM

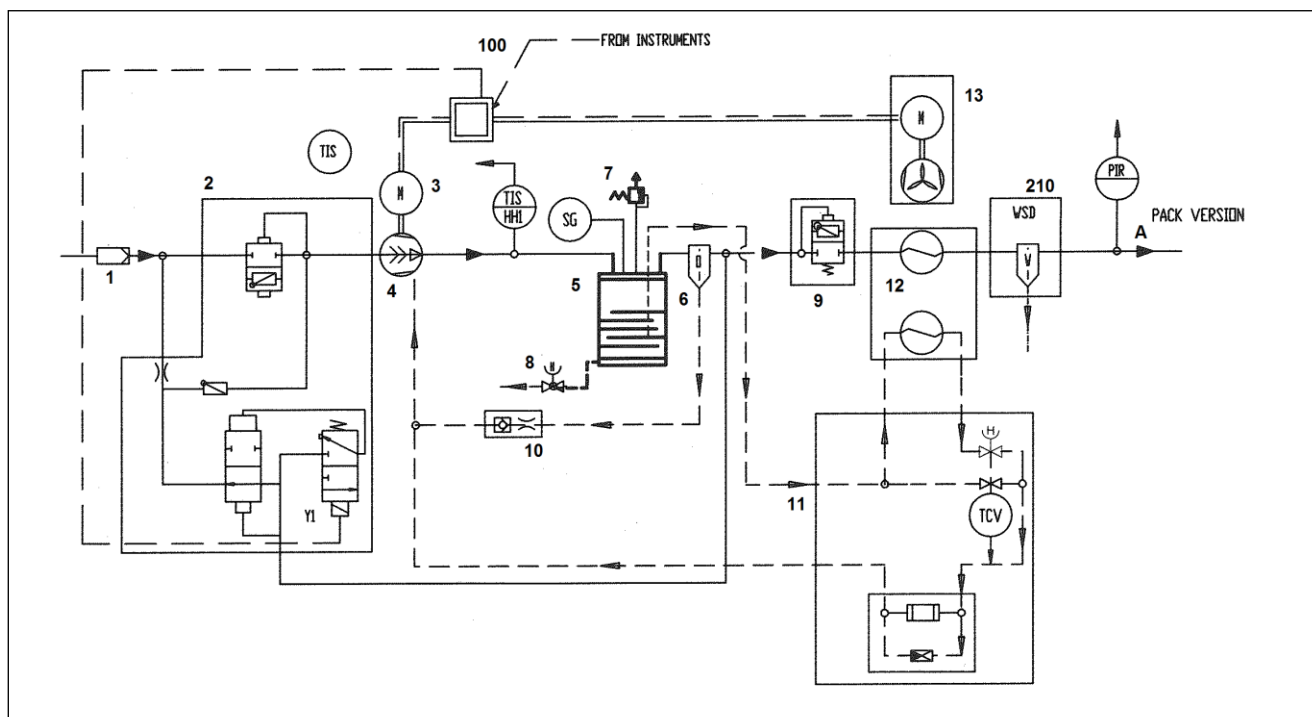

1 AIR FILTER	12 AIR-OIL RADIATOR
2 AIR INTAKE UNIT	13 FAN
3 ELECTRIC MOTOR	100 CONTROL BOARD
4 SCREW COMPRESSOR	210 SEPARATOR FILTER (OPTIONAL)
5 OIL TANK	
6 AIR/OIL SEPARATOR FILTER	
7 SAFETY VALVE	
8 OIL DRAIN	
9 MINIMUM VALVE	
10 NON-RETURN VALVE	
11 THERMOSTATIC VALVE	

27.0 VARIABLE SPEED

The "Variable speed" version of the machine is controlled by an INVERTER.

The equipment is factory calibrated and does not require any adjustment of parameters.

The modulation pressure is set at 0.5 bar lower than the maximum pressure: depending on the air consumption, the INVERTER will adjust the motor speed.

MODULATION PRESSURE CALIBRATION

The compressor modulation pressure is set at a fixed value of 0.5 bar less than the maximum pressure. By modifying this value (Parameter P0), the modulation pressure value is therefore also modified.

