

# nano

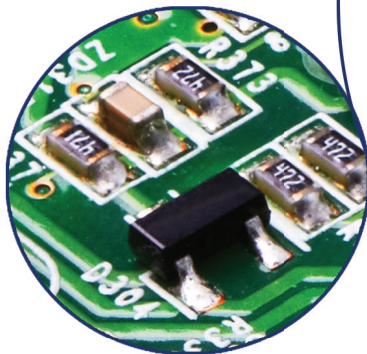
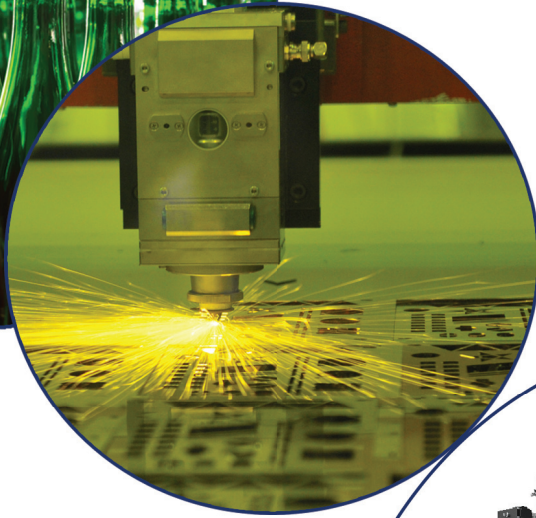

## high-capacity nitrogen generators

nitrogen purity: 95% to 99.999%

# “The GEN<sub>2</sub>-MAX unit allowed nitrogen deliveries and reduced

*equipment manufacturer- southeastern US*

Nitrogen is a dry, inert gas which is used in many commercial and industrial applications to improve quality or where oxygen may be harmful to the product or processes.

With traditional methods of gas supply such as liquid or bottled nitrogen, users are oftentimes responsible for hidden costs such as rental fees, refill and delivery surcharges, order processing charges as well as environmental fees.

Nitrogen generators begin with clean, dry compressed air to create a continuous supply of high purity nitrogen. Generating nitrogen in-house is a cost-effective and reliable alternative to the use of cylinder or liquid nitrogen across a wide range of applications.

## PSA nitrogen generation

Pressure Swing Adsorption (PSA) nitrogen generation uses air which is 79% nitrogen and removes the oxygen to provide the higher purities needed for your process.





**and for us to eliminate our liquid nitrogen operating cost.”**

nano GEN<sub>2</sub>-MAX high-capacity nitrogen gas generators

- for large flow applications up to 101,400 scfh
- payback typically between 6 to 24 months
- easy installation with minimum cost and disruption
- user has complete control fulfilling nitrogen gas demand
- generate as little or as much nitrogen gas as needed at a fraction of delivered gas cost



# BENEFITS

## guaranteed performance

- 100% functional tested at our factory
- 1 YEAR WARRANTY

## rapid return on investment

- significant cost savings over cylinder or liquid supply provides a typical return on investment of less than 24 months
- ecomode energy savings control reduces energy consumption during periods of low demand resulting in significant reduction of operational cost

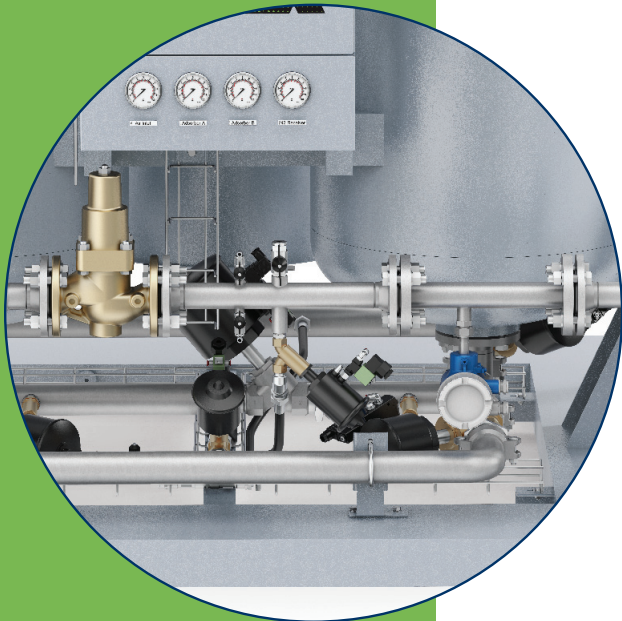

## design quality

- advanced welded vessels designed for operation at high temperatures guarantees ultimate reliability in the most extreme operating conditions
- compliance with international electrical and mechanical codes saves administration costs to comply with local standards

## complete scope of supply

- nitrogen flow meter as standard
- advanced integral zirconia oxygen analyzer - continuously measures and guarantees gas quality (5 year zirconia sensor life)
- outlet pressure control valve
- inlet compressed air pressure dew point sensor as standard; outlet nitrogen pressure dew point sensor available as option

## easy to install & maintain

- rigid base frame with integrated forklift slots facilitates ease of movement and placement using standard forklift
- inter-connecting piping and wiring assures quick installation, commissioning and start up with minimal installation costs

## safe & reliable

- eliminates the safety hazards of transporting and storing pressurized gas cylinders or liquid nitrogen

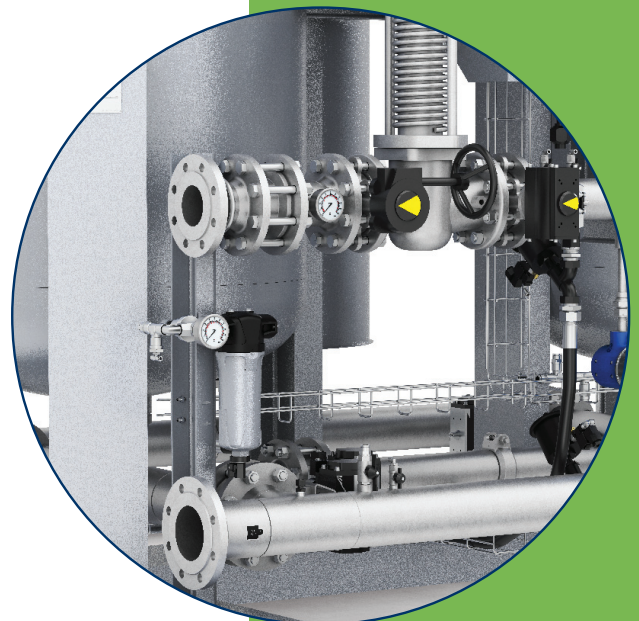



# HOW IT WORKS

The technologically advanced nano GEN<sub>2</sub>-MAX nitrogen generator operates on the Pressure Swing Adsorption (PSA) principle to produce a continuous uninterrupted stream of nitrogen gas from clean dry compressed air. Two specially designed welded vessels with full size top flanges are filled with Carbon Molecular Sieve (CMS) for the most effective, high density filling. Joined via inter-connecting piping, the high density filled vessels produce a dual bed system. After a preset time the control system automatically switches the beds. One bed is online generating nitrogen while the other is being regenerated.

During regeneration, the oxygen that has been collected in the CMS stage is exhausted to atmosphere. A small portion of the outlet nitrogen gas is expanded into the bed to accelerate the regeneration process.

- A** clean compressed air enters the inlet into GEN<sub>2</sub>-MAX unit where the inlet valves direct the flow to either the left or right column sets
- B** after passing through the inlet valve, the compressed air enters one of the two welded vessels
- C** the compressed air then flows up through the Carbon Molecular Sieve (CMS) beds where oxygen and other trace gases are preferentially adsorbed and allows the nitrogen to pass through
- D** the nitrogen gas then passes through the supporting bed layer with integrated filter into the outlet manifold before exiting through the outlet valves
- E** the nitrogen gas continues to the buffer vessel (not shown) and nano F<sup>1</sup> buffer vessel filter before returning to the GEN<sub>2</sub>-MAX unit for purity monitoring, flow & purity regulation
- F** high purity nitrogen is now ready to leave the unit for the application

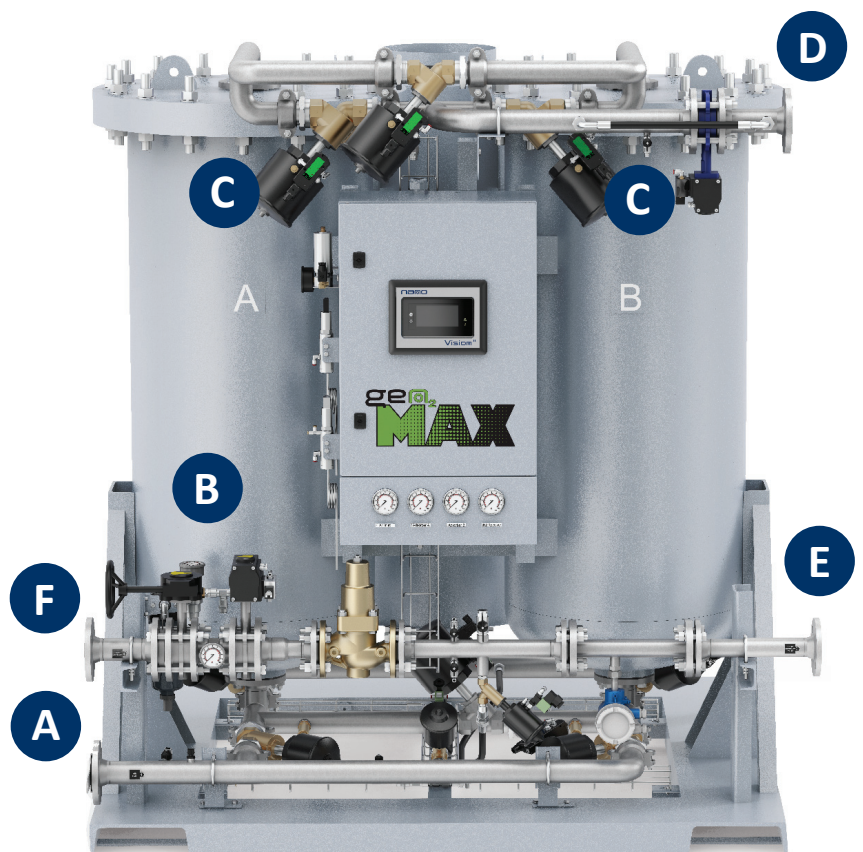

# FEATURES

## Vision<sup>01</sup> PLC/HMI controlled operation

- user-friendly PLC uses advanced algorithms for maximum reliability
- comprehensive, pro-active maintenance display
- ethernet connection for local monitoring via LAN/DCS system
- optional remote service and performance monitoring

## quality components

- reliable high performance butterfly valves designed for reliability, long service life and ease of maintenance

## vessel construction

- specially designed absorber vessels with full size top flange for the most effective, high density filling of the high-grade carbon molecular sieve (CMS)
- equipped with full size bottom inlet strainer to achieve maximum flow distribution preventing movement and crushing of CMS as well as minimizing possibility of channeling and maximizing performance in adsorption of oxygen

## CMS protection

- to allow continuous operation for more than 15 years, units are equipped with safety features to eliminate the risk of CMS being damaged by low quality compressed air supply, poor start-ups and unexpected shutdowns
- continuous monitoring of the compressed air quality via a Pressure Dew Point (PDP) sensor installed at the compressed air inlet prevents CMS damage

## self-regulation and stable purity

- user controlled outlet flow, pressure and purity

## ecomode

- ecomode allows additional energy saving to be attained by keeping the purity within a narrow band of the required value
- achieved by elongating the adsorption cycle and consequently saving valuable compressed air and nitrogen consumed by the generator during column changeover

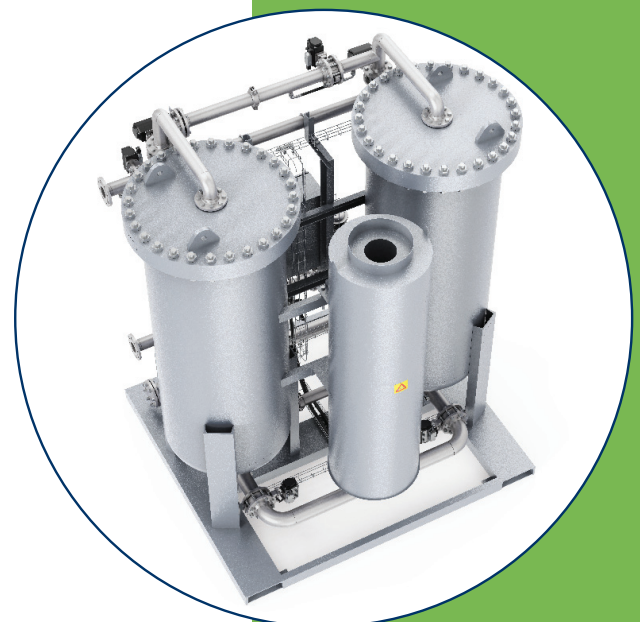
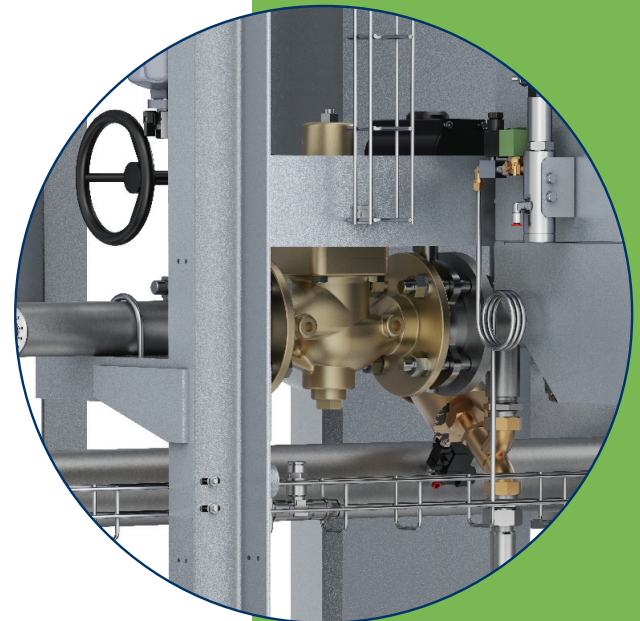

# SPECIFICATIONS

generator model	rated outlet flow <sup>(1)</sup>	nitrogen purity at the outlet (maximum oxygen content)*										dimensions (inches)			approx. weight (lbs)
		99.999% (10 ppm)	99.99% (100 ppm)	99.95% (500 ppm)	99.9% (0.10%)	99.5% (0.50%)	99% (1%)	98% (2%)	9% (3%)	96% (4%)	95% (5%)	A	B	C	
GEN2-MAX 5.5K	scfh	1620	2420	3119	4093	5556	6496	7946	8998	10012	11049	72	67	81	5180
GEN2-MAX 7.5K	scfh	2037	3042	3921	5145	6984	8166	9988	11311	12585	13888	72	67	90	5690
GEN2-MAX 9.5K	scfh	2520	3960	5160	6720	9360	11100	13560	15720	17460	19320	88	71	103	7055
GEN2-MAX 12K	scfh	3240	5040	6600	8640	12120	14340	17460	20220	22500	24900	102	71	104	8378
GEN2-MAX 15K	scfh	3960	6120	8040	10500	14700	17400	21240	24540	27360	30240	105	71	104	10582
GEN2-MAX 17K	scfh	4500	6960	9120	11880	16620	19680	24000	27780	30960	34260	107	83	121	14110
GEN2-MAX 20K	scfh	5460	8520	11100	14520	20400	24060	29400	34020	37920	41940	113	83	121	15432
GEN2-MAX 25K	scfh	6540	10200	13320	17400	24360	28800	35220	40680	45360	50160	116	83	121	16976
GEN2-MAX 31K	scfh	8220	12780	16680	21840	30540	36120	44100	51000	56760	62880	146	123	157	22708
GEN2-MAX 39K	scfh	10440	16200	21180	27660	38760	45840	55920	64680	72060	79740	149	123	166	26455
GEN2-MAX 50K	scfh	13260	20640	26880	35160	49260	58260	71100	82260	91620	101400	152	123	174	31306

## specifications

design operating pressure range	72.5 - 145 psig (5 - 10 barg)
design operating temperature range	41 - 122°F (5 - 50°C)
recommended operating temperature range	41 - 95°F (5 - 35°C)
maximum inlet particulate	0.1 micron
maximum inlet dew point	+45°F (+7°C) PDP <sup>(2)</sup>
recommended inlet dew point	-37.4°F (+4°C) PDP <sup>(2)</sup>
maximum inlet oil content	0.01 ppm <sup>(3)</sup>
supply voltage	100 - 240 VAC (50 or 60Hz)

(1) at 100 psig (7 barg) inlet pressure and 68 - 77°F (20 - 25°C) inlet temperature. For outlet flow at all other conditions refer to the correction factors above or contact support@nano-purification.com

(2) PDP must always be lower than ambient temperature

(3) including oil vapor

(4) technical specifications subject to change without notice. Direct inquiries to support@nano-purification.com or contact 704.897.2182

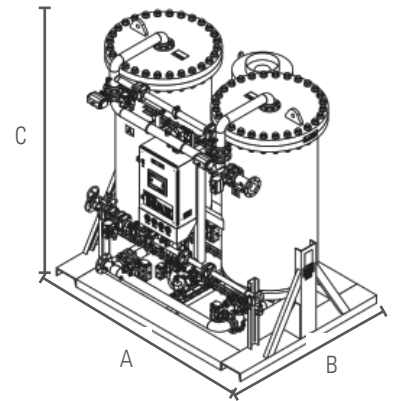

GEN2-MAX 5.5K to GEN2-MAX 50K





# EXPERIENCE. CUSTOMER. SERVICE.

Leading edge technology and hundreds of years of *experience*. . . nano-purification solutions, your world-class manufacturer of state-of-the-art compressed air and gas solutions to industry.

Our commitment at nano is to work alongside our *customers* and provide unique solutions with the highest quality products to solve your specific challenges.

A wealth of experience and leading edge products are only part of the equation. nano recognize that world-class customer *service* is the most important component to any successful business.



## DESIGN

Our experienced team of design engineers are always looking for new and unique technologies and products to bring you the highest level of performance and lowest overall operating cost.

## RESEARCH & DEVELOPMENT

Our R&D team endeavor to provide solutions that go beyond developing an existing product. They are continually researching new technologies which can provide unique advantages over competitive offerings.

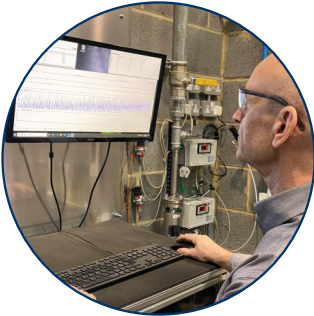

## MANUFACTURE

The reliable and energy saving nano GEN<sub>2</sub>MAX range of nitrogen generators are manufactured in our state-of-the-art facility to the highest standards of build quality to ensure equipment reliability and high levels of performance.

## ENVIRONMENTALLY FRIENDLY

Through both product development and manufacturing, we strive to produce high quality products compliant to both local and global environmental legislation. Reduction of carbon footprint through energy saving products and use of environmentally friendly components are our commitment to you.



nano-purification solutions  
Charlotte, North Carolina  
United States

nano-purification solutions TN  
Maryville, Tennessee  
United States

nano-purification solutions Canada  
St. Catharines, Ontario  
Canada

nano-purification solutions Ltd.  
Gateshead, Tyne and Wear  
United Kingdom

nano-purification solutions GmbH  
Erkelenz, Germany

nano-purification solutions Asia  
Singapore

Tel: 704.897.2182  
Fax: 704.897.2183  
Email: support@nano-purification.com  
Web: www.n-psi.com

[www.n-psi.com](http://www.n-psi.com)