

THIS DRAWING & SPECIFICATIONS ARE PROPERTY OF MORGANTON PRESSURE VESSELS AND MAY NOT BE COPIED, REPRODUCED, OR USED IN WHOLE OR PART, AS A BASIS FOR DESIGN MANUFACTURE OR SALE WITHOUT PRIOR PERMISSION FROM MORGANTON PRESSURE VESSELS.

DESIGN INFORMATION	
SPECIFICATION	VALUE
DIAMETER (O.D.)	12.000"
MAWP	200 PSI AT 650°F
MDMT	-20°F AT 200 PSI
CAPACITY	APPROX 12 GALLONS
APPROX. WEIGHT	40 LBS

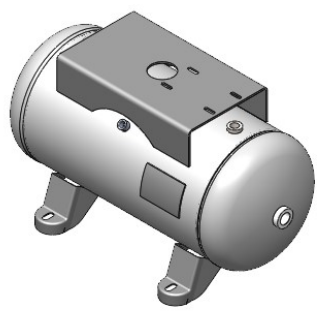
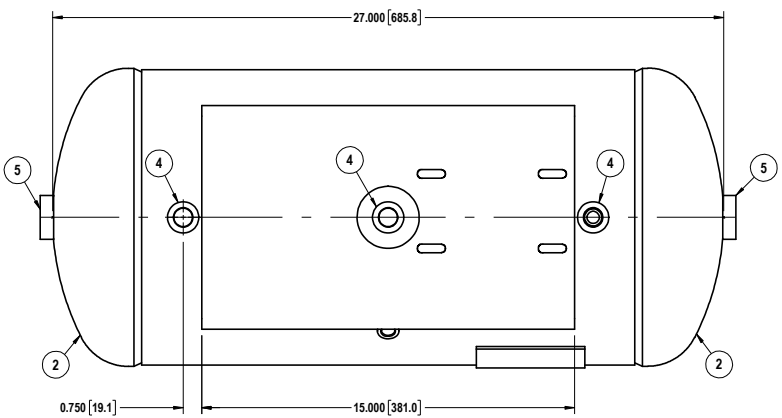
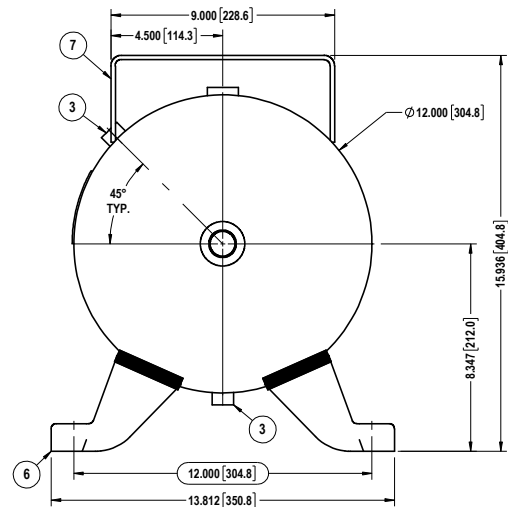
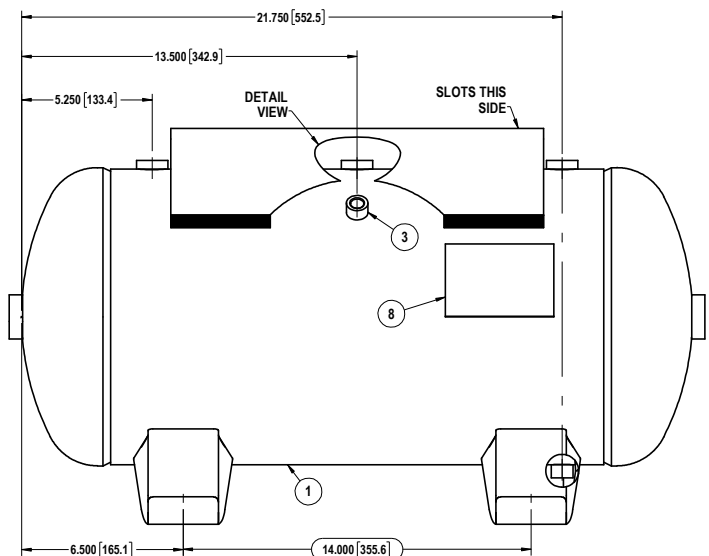

ITEM#	DESCRIPTION	QTY.
8	NAME PLATE	1
7	TOP PLATE	1
6	LEG	4
5	3/4" NPT COUPLING	2
4	1/2" NPT COUPLING	3
3	1/4" NPT COUPLING	2
2	HEAD	2
1	SHELL	1

<p>MORGANTON -ASME- 12 GALLON HORIZONTAL AIR RECEIVER SECT. VIII DIV. 1</p>	<p>TOLERANCES, IF NOT INDICATED, ACCORDING TO: C-G SE 03.03 / 3</p>
	<p>DWG. NO. VES05198</p>
	<p>NOT FOR PRODUCTION USE</p>