

THIS DRAWING & SPECIFICATIONS ARE PROPERTY OF MORGANTON PRESSURE VESSELS AND MAY NOT BE COPIED, REPRODUCED, OR USED IN WHOLE OR PART, AS A BASIS FOR DESIGN MANUFACTURE OR SALE WITHOUT PRIOR PERMISSION FROM MORGANTON PRESSURE VESSELS.

DESIGN INFORMATION	
SPECIFICATION	VALUE
DIAMETER (O.D.)	16.000"
MAWP	200 PSI AT 650°F
MDMT	-20°F AT 200 PSI
CAPACITY	APPROX 20 GALLONS
APPROX. WEIGHT	55 LBS

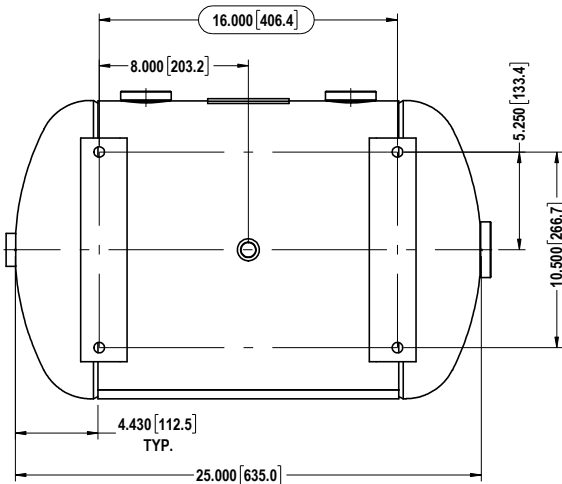
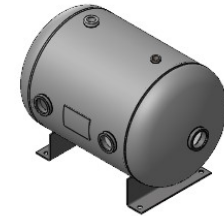
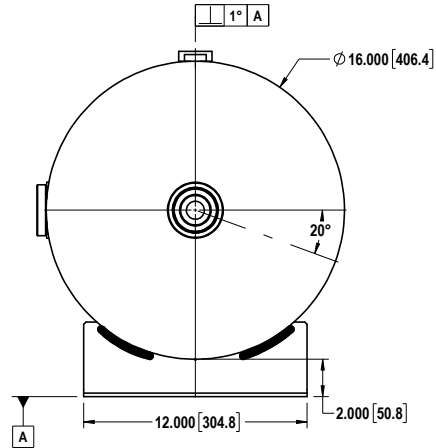
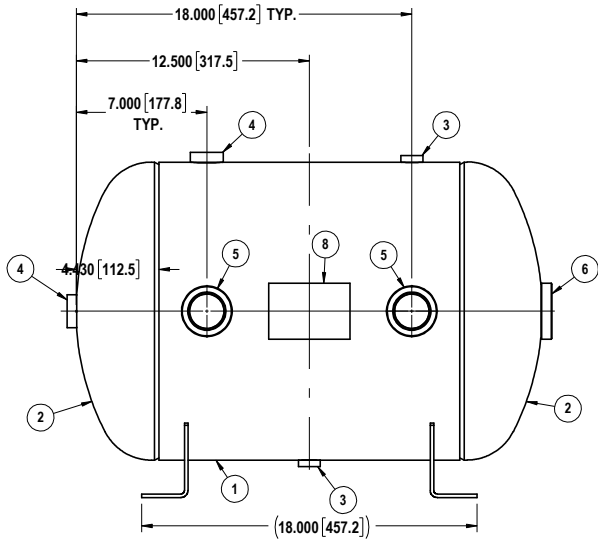

ITEM#	DESCRIPTION	QTY.	PART #
8	NAME PLATE	1	LAB00038
7	SUPPORT	2	CAN15906
6	2" NPT COUPLING	1	SOK00282
5	1-1/2" NPT COUPLING	2	SOK00312
4	3/4" NPT COUPLING	2	SOK00289
3	1/2" NPT COUPLING	2	SOK00286
2	HEAD	2	HEA00443
1	SHELL	1	PSV03521

MORGANTON	TOLERANCES, IF NOT INDICATED, ACCORDING TO: C-G SE 03.03 / 3
	DWG. NO. VES0010071
20 GALLON HORIZONTAL VESSEL -ASME- SEC. VIII DIV. 1	REV. 0

NOT FOR PRODUCTION USE