



Pressure Vessels & Air Receivers



Setting the Standard for Quality and Reliability

Pressure Vessel Codes & Registrations:

The items listed in this catalog have been designed and constructed in accordance with the ASME Section VIII Division I Code latest edition and are registered with the National Board of Boiler and Pressure Vessel Inspectors. Most of the items listed in this catalog are also approved for use in Canada (CRN).

Manchester Tank has the capability to also design and construct pressure vessels to many other codes, such as:

- American Bureau of Shipping (ABS)
- United States Coast Guard (USCG)
- Department of Transportation (DOT)
- Transport Canada (TC)
- European Pressure Equipment Directive (PED)
- Transportable European Pressure Equipment Directive (TPED)
- Malaysia – Department of Occupational & Health (DOSH)
- Singapore – Ministry of Manpower (MOM)
- Australia Design Approval
- Brazilian NR-13
- UN-Portable
- Intermediate Bulk Container (IBC)
- And many other international codes

Manufacturing Capabilities:

Manchester Tank is capable of producing pressure vessels made from carbon steel, stainless steel and aluminum material with sizes ranging from 3" diameter at 3,000 PSI to 120" diameter at 200 PSI.

Engineering Capabilities:

Manchester Tank's engineering professionals are highly trained in AutoCAD & SolidWorks 3D CAD to support your organization's technical design requirements. With 15 design stations and a Professional Engineer on staff, Manchester Tank is committed to fulfill your organization's custom equipment needs in a timely manner.

Paint Specifications:

The exterior surface of the items listed in this catalog has been painted with one coat of standard shop primer to serve as a temporary rust preventative. A wide variety of custom interior and exterior coatings are available.

For your convenience, Manchester Tank's standard Pressure Vessels & Air Receiver drawings are available for download. Visit Manchester Tank's website at mantank.com

Table of Contents:

Vertical Air Receivers / 10-120 Gallons _____	1
Vertical Air Receivers / 120-500 Gallons _____	2
Vertical Air Receivers / 660-10,000 Gallons _____	3
Vacuum Receivers / 60-400 Gallons _____	4
Horizontal Air Receivers / 10-240 Gallons _____	5
Horizontal Air Receivers / 400-2,560 Gallons _____	6
Universal Horizontal Air Receivers / 1-30 Gallons _____	7
Horizontal Grasshopper Tanks / 30-240 Gallons _____	8
Horizontal Gas Driven Tanks _____	9
Extended Top Plate Tanks / 30-240 Gallons _____	10
Technical Aids _____	11
Vessel Installation & Maintenance Recommendations _____	12-13

Vertical Air Receivers / 10-120 Gallons

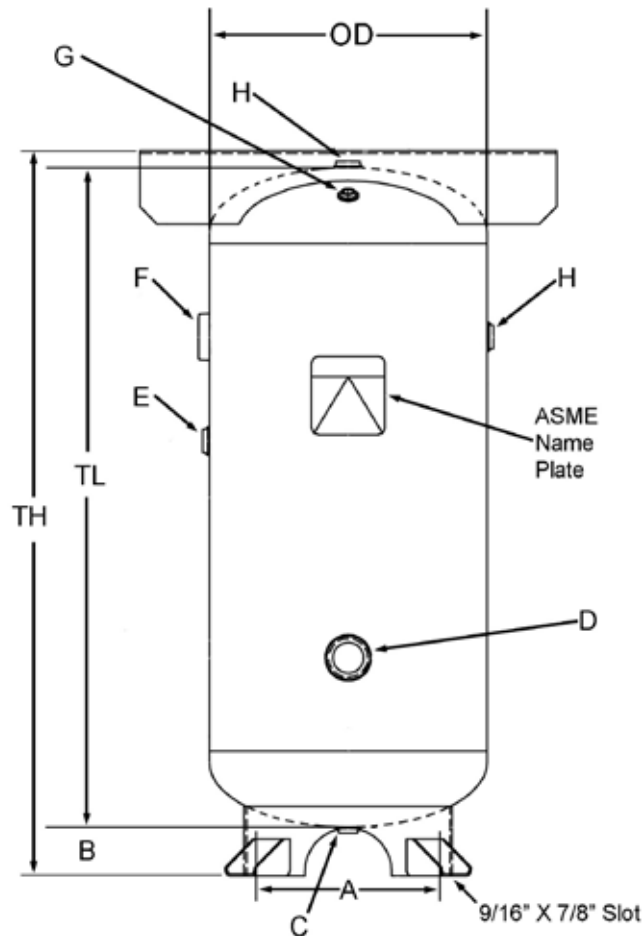

For your convenience, Manchester Tank's standard Pressure Vessel & Air Receiver drawings are available for download. Visit Manchester Tank's website at mantank.com

NOM CAP		Part #	MAWP	Top Plate	TW	DIMENSIONS IN INCHES					NPT OPENINGS					
Gal	Cu Ft					OD	TL	TH	A	B	C	D	E	F	G	H
10	1.34	302400	200	NONE	37	10	30	32.38	11.25	2.38	1/2	N/A	N/A	3/4	1/4	3/4
10	1.34	302401	300	NONE	41	10	30	32.38	11.25	2.38	1/2	N/A	N/A	3/4	1/4	3/4
15	2.01	302402	200	NONE	46	12	33	35.38	12.75	2.38	1/2	N/A	N/A	3/4	1/4	3/4
15	2.01	302403	300	NONE	60	12	33	35.38	12.75	2.38	1/2	N/A	N/A	3/4	1/4	3/4
20	2.67	302404	200	NONE	60	14	33	35.25	15.00	2.25	1/2	1 1/2	N/A	1 1/2	1/4	3/4
20	2.67	302405	300	NONE	97	14	33	35.25	15.00	2.25	1/2	1 1/2	N/A	1 1/2	1/4	3/4
30	4.01	302406	200	NONE	85	16	38	40.81	15.00	2.81	1/2	1 1/2	3/4	1 1/2	1/4	3/4
30	4.01	302407	300	NONE	117	16	38	40.81	15.00	2.81	1/2	1 1/2	3/4	1 1/2	1/4	3/4
30	4.01	302408	200	.18 x 10 x 24	107	16	38	41.81	15.00	2.81	1/2	1 1/2	3/4	1 1/2	1/4	3/4
30	4.01	302409	300	.18 x 10 x 24	139	16	38	41.81	15.00	2.81	1/2	1 1/2	3/4	1 1/2	1/4	3/4
60	8.02	302410	200	NONE	159	20	48	50.75	17.00	2.75	1/2	2	3/4	2	1/4	3/4
60	8.02	302411	300	NONE	219	20	48	50.75	17.00	2.75	1/2	2	3/4	2	1/4	3/4
60	8.02	302412	200	.18 x 13.5 x 30	192	20	48	52.06	17.00	2.75	1/2	2	3/4	2	1/4	3/4
60	8.02	302413	300	.18 x 13.5 x 30	253	20	48	52.06	17.00	2.75	1/2	2	3/4	2	1/4	3/4
80	10.70	302414	200	NONE	198	20	63	65.75	17.00	2.75	1/2	2	1 1/4	2	1/4	1 1/4
80	10.70	302415	300	NONE	268	20	63	65.75	17.00	2.75	1/2	2	1 1/4	2	1/4	1 1/4
80	10.70	302417	200	NONE	220	24	46	49.19	21.00	3.19	1/2	2	1 1/4	2	1/4	1 1/4
80	10.70	302418	300	NONE	282	24	46	49.19	21.00	3.19	1/2	2	1 1/4	2	1/4	1 1/4
80	10.70	302419	200	.18 x 13.5 x 30	257	24	46	51.25	21.00	3.19	1/2	2	1 1/4	2	1/4	1 1/4
80	10.70	302420	300	.18 x 13.5 x 30	319	24	46	51.25	21.00	3.19	1/2	2	1 1/4	2	1/4	1 1/4
120	16.04	302423	200	NONE	355	30	46	54.00	27.00	8.00	1/2	2	2	2	1/4	2
120	16.04	302424	200	.25 x 15 x 40	415	30	46	55.50	27.00	8.00	1/2	2	2	2	1/4	2
120	16.04	302425	300	.25 x 15 x 40	535	30	46	55.50	27.00	8.00	1/2	2	2	2	1/4	2

Vertical Air Receivers / 120-500 Gallons

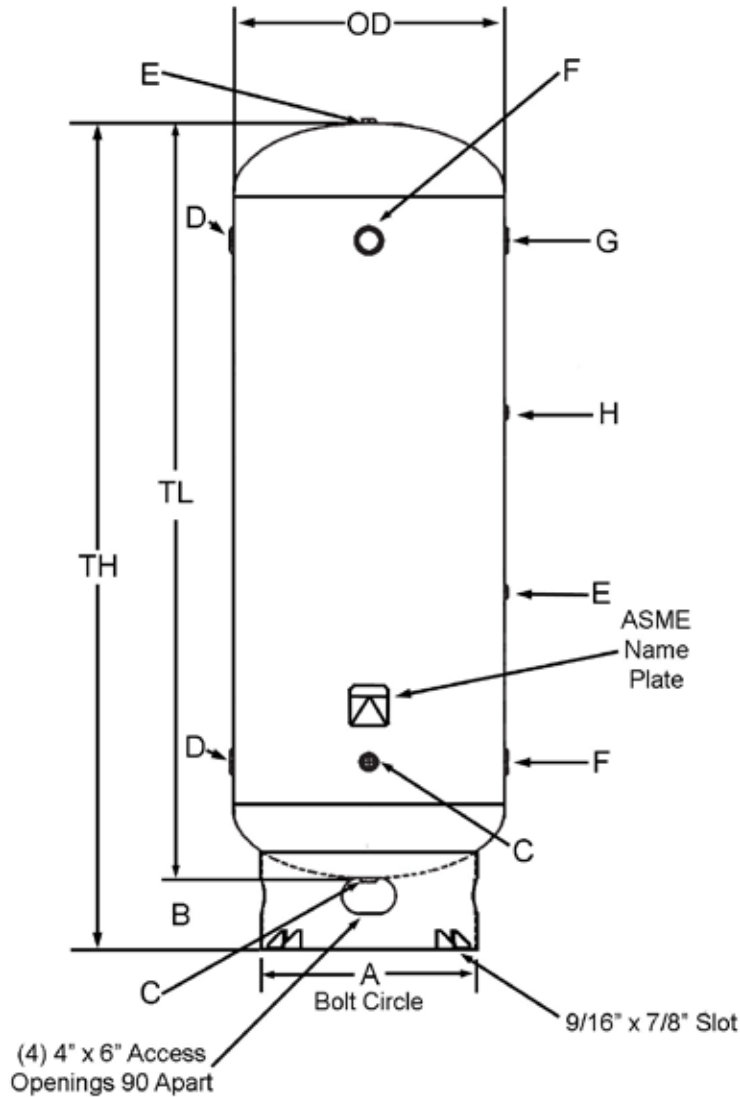

For your convenience, Manchester Tank's standard Pressure Vessel & Air Receiver drawings are available for download. Visit Manchester Tank's website at mantank.com

NOM CAP		Part #	MAWP	TW	DIMENSIONS IN INCHES					NPT OPENINGS					
Gal	Cu Ft				OD	TL	TH	A	B	C	D	E	F	G	H
120	16.04	302421	200	329	24	67	75	21	8	1	2	1/2	2	1 1/2	1/4
120	16.04	302422	300	379	24	67	75	21	8	1	2	1/2	2	1 1/2	1/4
200	26.74	302426	200	421	30	72	80	27	8	1	2	1/2	2	1 1/2	1/4
200	26.74	302427	300	720	30	72	80	27	8	1	2	1/2	2	1 1/2	1/4
240	32.09	302428	200	497	30	84	92	27	8	1	2	1/2	2	1 1/2	1/4
240	32.09	302429	300	930	30	84	92	27	8	1	2	1/2	2	1 1/2	1/4
400	53.48	302432	165	660	36	93	101	33	8	1	2	1/2	3	1 1/2	1/4
400	53.48	302433	200	783	36	93	101	33	8	1	2	1/2	3	1 1/2	1/4
500	66.84	302436	165	950	36	116	124	33	8	1	2	1/2	3	1 1/2	1/4
500	66.84	302437	200	910	36	116	124	33	8	1	2	1/2	3	1 1/2	1/4

Vertical Air Receivers / 660-10,000 Gallons

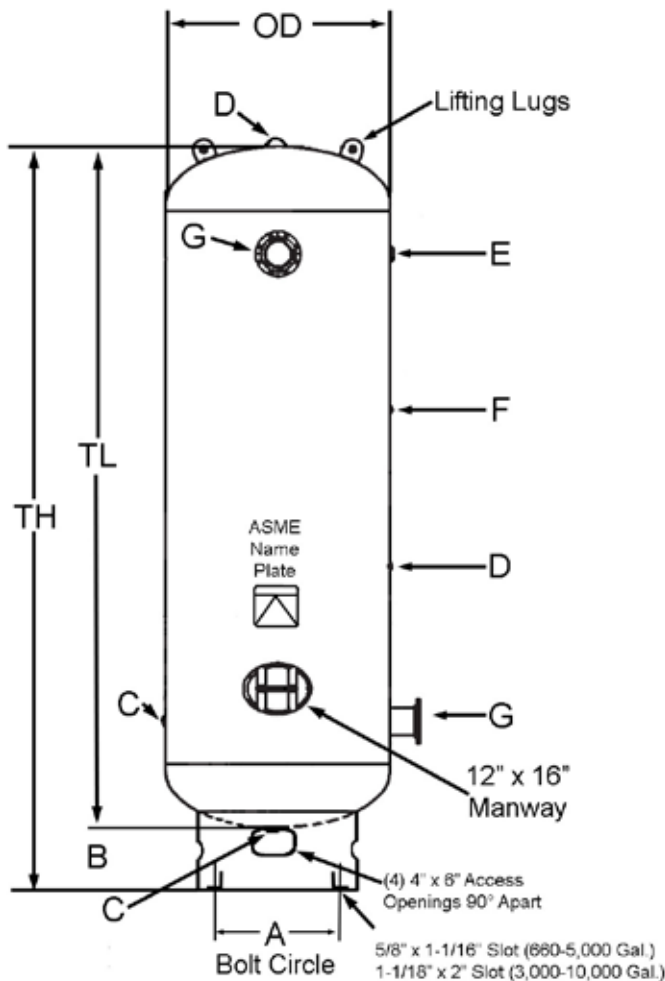

NOM CAP		Part #	MAWP	TW	DIMENSIONS IN INCHES					NPT OPENINGS				
Gal	Cu Ft				OD	TL	TH	A	B	C	D	E	F	G
660	88.24	302439	165	1365	42	117	125	36.50	8	1	1	3	1/4	3
660	88.24	302440	200	1570	42	117	125	36.50	8	1	1	3	1/4	3
1060	141.71	302443	165	1780	48	144	152	42.50	8	1	1	3	1/4	6"RFSO
1060	141.71	302444	200	2036	48	144	152	42.50	8	1	1	3	1/4	6"RFSO
1550	207.22	302446	165	2580	54	166	174	42.50	8	1 1/4	1	3	1/4	6"RFSO
1550	207.22	302447	200	3089	54	166	174	42.50	8	1 1/4	1	3	1/4	6"RFSO
2200	294.12	302449	165	3932	60	190	198	48.50	8	1 1/4	1	3	1/4	6"RFSO
2200	294.12	302450	200	4100	60	190	198	48.50	8	1 1/4	1	3	1/4	6"RFSO
2560	242.25	302452	165	4362	60	220	228	48.50	8	1 1/4	1	3	1/4	6"RFSO
2560	242.25	302453	200	4375	60	220	228	48.50	8	1 1/4	1	3	1/4	6"RFSO
3000	401.07	302454	137	5700	66	214	222	53.00	8	1 1/4	1	3	1/4	6"RFSO
3000	401.07	302455	165	5700	66	214	222	53.00	8	1 1/4	1	3	1/4	6"RFSO
3800	508.02	302457	165	6800	72	228	236	59.00	8	1 1/4	1	3	1/4	6"RFSO
5000	668.45	305653	165	8500	72	305	313	59.00	8	1 1/4	1	3	1/4	6"RFSO
5000	668.45	305995	200	11200	72	305	313	59.00	8	1 1/4	1	3	1/4	6"RFSO
5000	668.45	302459	165	10500	84	232	240	70.00	8	1 1/4	1	3	1/4	6"RFSO
5000	668.45	304718	200	10800	84	232	240	70.00	8	1 1/4	1	3	1/4	6"RFSO
8000	1069.52	305138	150	12300	84	355	363	70.00	8	1 1/4	1	3	1/4	6"RFSO
8000	1069.52	304807	137	14000	96	276	284	78.00	8	1 1/4	1	3	1/4	6"RFSO
10000	1336.90	303970	137	15700	108	275	283	87.00	8	1 1/4	1	3	1/4	6"RFSO

Vacuum Receivers / 60-400 Gallons

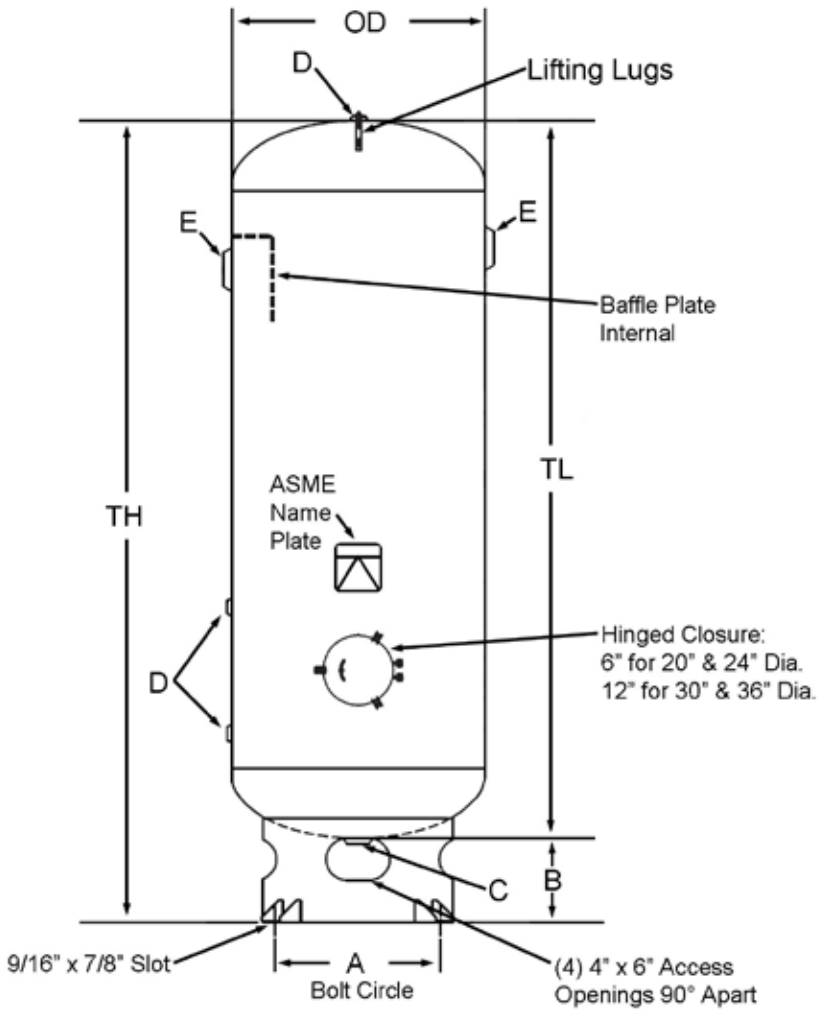

For your convenience, Manchester Tank's standard Pressure Vessel & Air Receiver drawings are available for download. Visit Manchester Tank's website at mantank.com

NOM CAP		Part #	MAWP	Vacuum Rating	TW	DIMENSIONS IN INCHES					NPT OPENINGS		
Gal	Cu Ft					OD	TL	TH	A	B	C	D	E
60	8.02	300956	150	29.9" Hg.	205	20	48	56	17	8	2	1/2	3
80	10.70	300957	150	29.9" Hg.	220	20	63	71	17	8	2	1/2	3
120	16.04	300958	150	29.9" Hg.	385	24	67	75	21	8	2	1/2	3
240	32.09	300959	150	29.9" Hg.	750	30	84	92	27	8	2	1/2	6" RFSO
400	53.48	300960	150	29.9" Hg.	900	36	93	101	31	8	2	1/2	6" RFSO

Horizontal Air Receivers / 10-240 Gallons

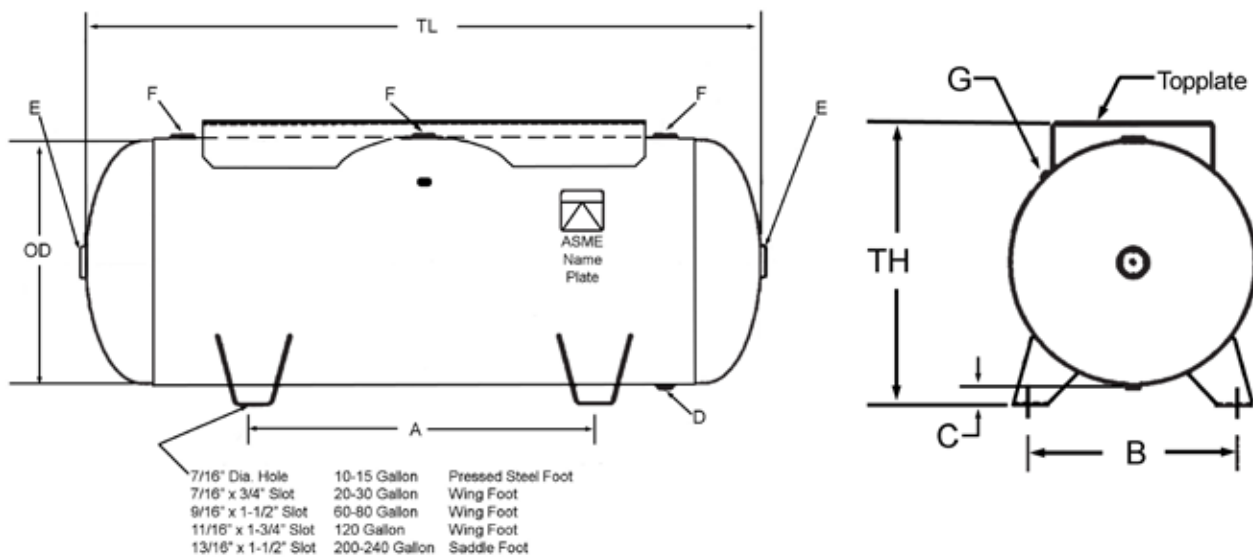

NOM CAP		Part #	MAWP	Top Plate	TW	DIMENSIONS IN INCHES						NPT OPENINGS			
Gal	Cu Ft					OD	TL	TH	A	B	C	D	E	F	G
10	1.34	302460	200	NONE	32	10	30	11.56	18	9.25	1.56	1/4	3/4	1/2	N/A
10	1.34	302461	200	.13 x 9 x 16	43	10	30	13.06	18	9.25	1.56	1/4	3/4	1/2	N/A
10	1.34	302462	300	.13 x 9 x 16	46	10	30	13.06	18	9.25	1.56	1/4	3/4	1/2	N/A
15	2.01	302463	200	NONE	51	12	33	13.06	20	11.00	1.06	1/4	3/4	1/2	N/A
15	2.01	302464	200	.13 x 9 x 18	51	12	33	14.56	20	11.00	1.06	1/4	3/4	1/2	N/A
15	2.01	302465	300	.13 x 9 x 18	66	12	33	14.56	20	11.00	1.06	1/4	3/4	1/2	N/A
20	2.67	302466	200	NONE	66	14	33	16.00	16	11.69	2.00	1/2	1 1/2	1/2	1/4
20	2.67	302467	200	.13 x 9 x 20	79	14	33	16.00	16	11.69	2.00	1/2	1 1/2	1/2	1/4
20	2.67	302468	300	.13 x 9 x 20	95	14	33	16.00	16	11.69	2.00	1/2	1 1/2	1/2	1/4
30	4.01	302469	200	NONE	89	16	38	18.00	20	12.81	2.00	1/2	1 1/2	3/4	1/4
30	4.01	302470	200	.18 x 10 x 24	111	16	38	20.63	20	12.81	2.00	1/2	1 1/2	3/4	1/4
30	4.01	302471	300	.18 x 10 x 24	140	16	40	20.63	20	12.81	2.00	1/2	1 1/2	3/4	1/4
60	8.02	302473	200	NONE	170	20	48	22.31	24	16.50	2.31	1/2	2	3/4	1/4
60	8.02	302474	200	.18 x 13.5 x 30	204	20	48	24.44	24	16.50	2.31	1/2	2	3/4	1/4
60	8.02	302475	300	.18 x 13.5 x 30	225	20	48	24.44	24	16.50	2.31	1/2	2	3/4	1/4
80	10.70	302476	200	NONE	214	20	63	22.31	32	16.50	2.31	1/2	2	1	1/4
80	10.70	302477	200	.25 x 15 x 40	263	20	63	24.06	32	16.50	2.31	1/2	2	1	1/4
80	10.70	302478	300	.25 x 15 x 40	350	20	63	24.06	32	16.50	2.31	1/2	2	1	1/4
120	16.04	302479	200	NONE	311	24	67	26.25	34	20.63	2.25	3/4	2	1 1/2	1/4
120	16.04	302480	200	.25 x 16 x 44	382	24	67	27.94	34	20.63	2.25	3/4	2	1 1/2	1/4
200	26.74	302482	200	NONE	538	30	72	33.00	38	23.50	3.00	1	2	2	1/4
200	26.74	302483	200	.25 x 19 x 48	632	30	72	35.69	38	23.50	3.00	1	2	2	1/4
240	32.09	302484	200	NONE	618	30	84	33.00	44	23.50	3.00	1	2	2	1/4
240	32.09	302485	200	.25 x 19 x 48	716	30	84	35.69	44	23.50	3.00	1	2	2	1/4

Horizontal Air Receivers / 400-2,560 Gallons

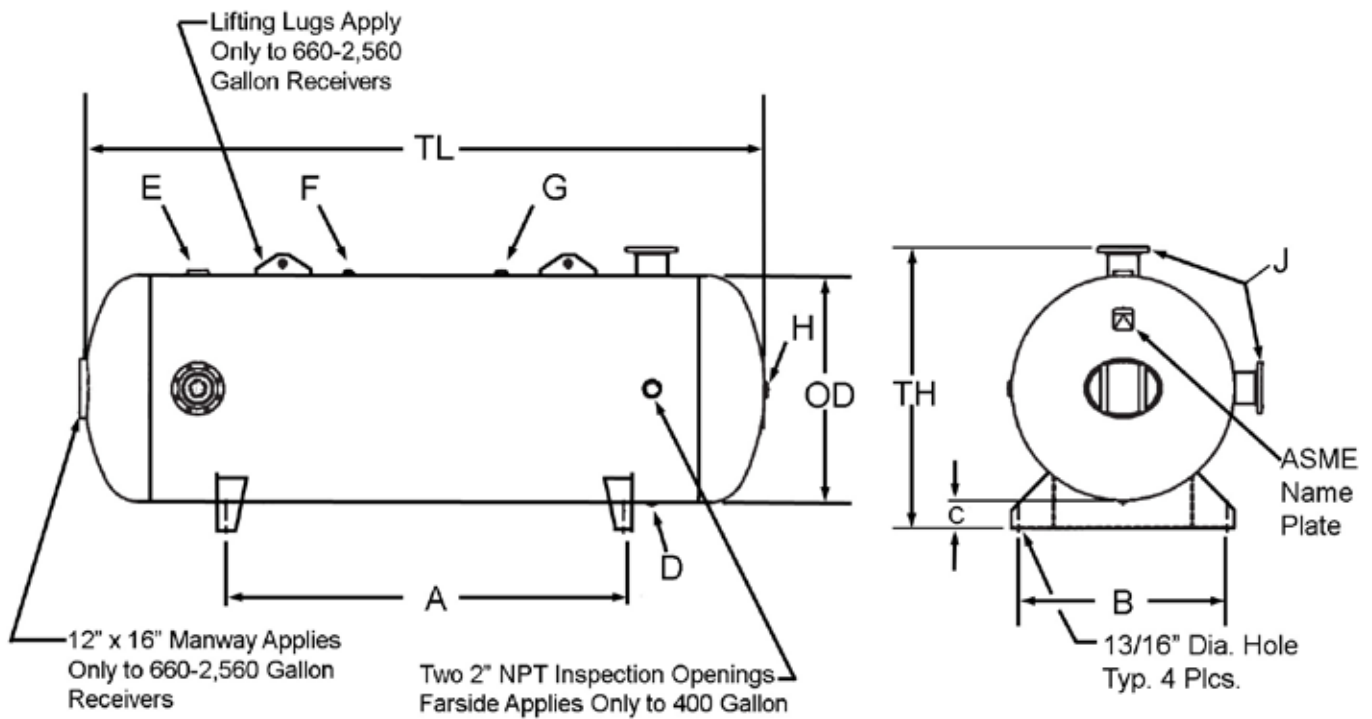

For your convenience, Manchester Tank's standard Pressure Vessel & Air Receiver drawings are available for download. Visit Manchester Tank's website at mantank.com

NOM CAP		Part #	MAWP	TW	DIMENSIONS IN INCHES						NPT OPENINGS					
Gal	Cu Ft				OD	TL	TH	A	B	C	D	E	F	G	H	J
400	53.48	302487	165	750	36	93	42	52	33	6	3/4	1 1/2	1/4	1/2	2	3
400	53.48	302488	200	925	36	93	42	52	33	6	3/4	1 1/2	1/4	1/2	2	3
660	88.24	302490	165	1375	42	117	48	70	39	6	3/4	3	1/4	1	2	3
660	88.24	302491	200	1375	42	117	48	70	39	6	3/4	3	1/4	1	2	3
1060	141.71	302493	165	2200	48	144	60	84	45	6	3/4	3	1/4	1	2	6" RFSO
1060	141.71	302494	200	2500	48	144	60	84	45	6	3/4	3	1/4	1	2	6" RFSO
1550	207.22	302496	165	2700	54	166	66	98	51	6	3/4	3	1/4	1	2	6" RFSO
2200	294.12	302498	165	4200	60	190	72	116	57	6	3/4	3	1/4	1	2	6" RFSO
2560	342.25	302500	165	4500	60	220	72	131	57	6	3/4	3	1/4	1	2	6" RFSO

Universal Horizontal Air Receivers / 1-30 Gallons

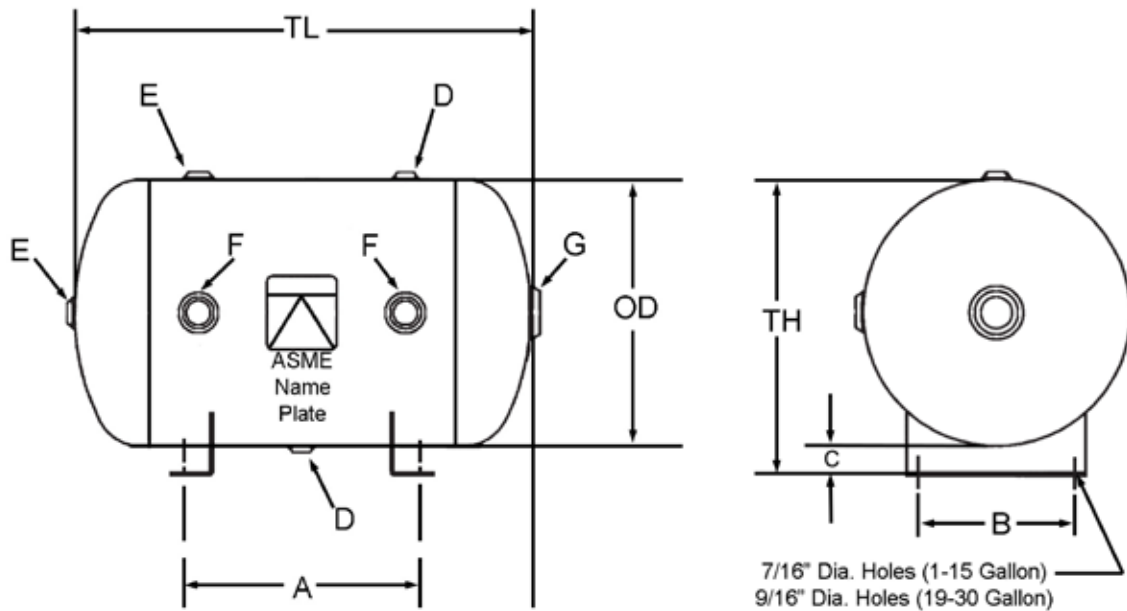

NOM CAP		Part #	MAWP	TW	DIMENSIONS IN INCHES							NPT OPENINGS			
Gal	Cu Ft				OD	TL	TH	A	B	C	D	E	F	G	
1	0.13	304978	200	15	6	11	8	7	3.5	2	1/2	3/4	3/4	1	
2	0.27	304980	200	17	8	11	10	7	4.5	2	1/2	3/4	3/4	1	
3	0.40	304982	200	22	8	16	10	10	4.5	2	1/2	3/4	3/4	1	
5	0.67	304932	200	25	10	16	12	10	6.5	2	1/2	3/4	3/4	1	
7	0.94	304934	200	29	12	17	14	10	6.5	2	1/2	3/4	3/4	1	
10	1.34	304936	200	35	12	23	14	10	6.5	2	1/2	3/4	3/4	1	
13	1.74	304938	200	45	14	23	16	15	8.5	2	1/2	3/4	1 1/2	1	
15	2.01	304940	200	51	14	26	16	15	8.5	2	1/2	3/4	1 1/2	1	
19	2.54	304942	200	59	16	25	18	16	10.5	2	1/2	3/4	1 1/2	2	
24	3.21	304944	200	72	16	31	18	16	10.5	2	1/2	3/4	1 1/2	2	
30	4.01	304946	200	85	18	31	20	16	10.5	2	1/2	3/4	1 1/2	2	

Horizontal Grasshopper Tanks / 30-240 Gallons

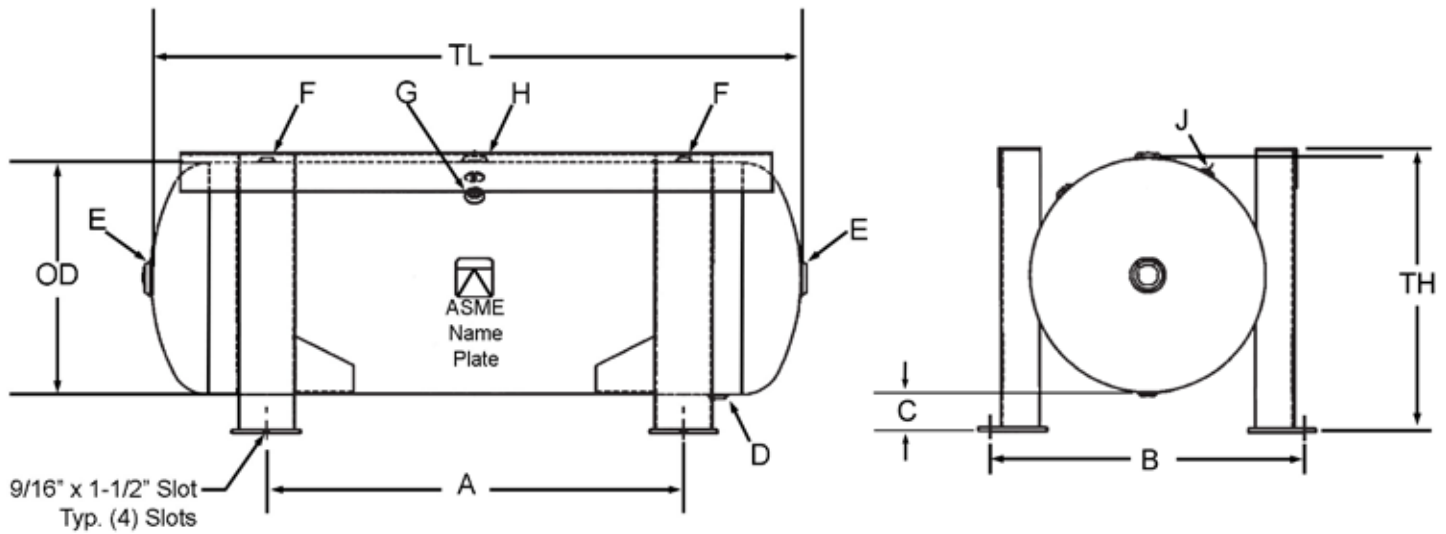

For your convenience, Manchester Tank's standard Pressure Vessel & Air Receiver drawings are available for download. Visit Manchester Tank's website at mantank.com

NOM CAP		Part #	MAWP	TW	DIMENSIONS IN INCHES						NPT OPENINGS					
Gal	Cu Ft				OD	TL	TH	A	B	C	D	E	F	G	H	J
30	4.01	305438	200	125	16	38	21	22	22.0	4	1/4	1 1/2	1/2	3/4	1 1/2	1/8
60	8.02	305439	200	260	20	48	25	27	26.5	4	3/4	2	1/2	3/4	1 1/2	1/8
80	10.70	305440	200	300	20	63	25	42	26.5	4	3/4	2	1/2	3/4	1 1/2	1/8
120	16.04	302481	200	435	24	67	29	43	32.0	4	3/4	2	1/2	3/4	1 1/2	1/8
200	26.74	302643	200	780	30	72	35	42	40.0	4	1	2	1/2	3/4	1 1/2	1/8
240	32.09	302652	200	820	30	84	35	54	40.0	4	1	2	1/2	3/4	1 1/2	1/8

Horizontal Gas Driven Tanks

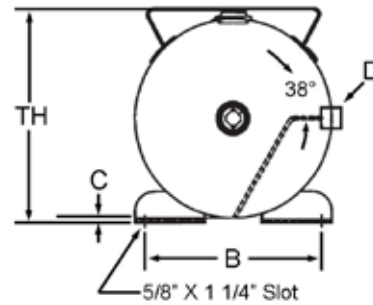
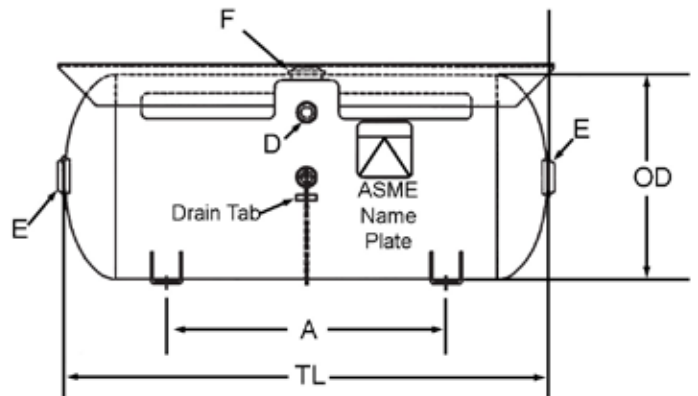
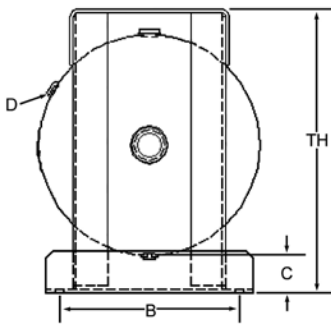
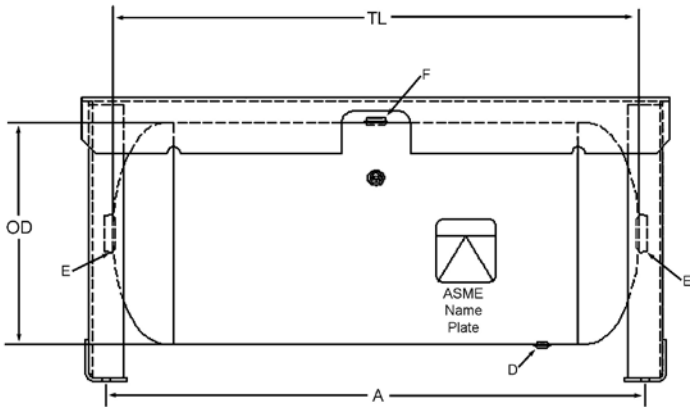

NOM CAP		Part #	MAWP	Top Plate	TW
Gal	Cu Ft				
30	4.01	34917	200	.25 x 11.5 x 42.5	161

DIMENSIONS IN INCHES						NPT OPENINGS		
OD	TL	TH	A	B	C	D	E	F
16	38	20.56	38.94	13.00	2.75	1/4	1 1/2	3/4

Part #34917 approved for use in California

NOM CAP		Part #	MAWP	Top Plate	TW
Gal	Cu Ft				
30	4.01	302472	200	.25 x 15 x 39	160

DIMENSIONS IN INCHES						NPT OPENINGS		
OD	TL	TH	A	B	C	D	E	F
16	38	17.25	22.00	13.13	0.38	1/4	1 1/2	1 1/4

Extended Top Plate Horizontal Air Receivers / 30-240 Gallons

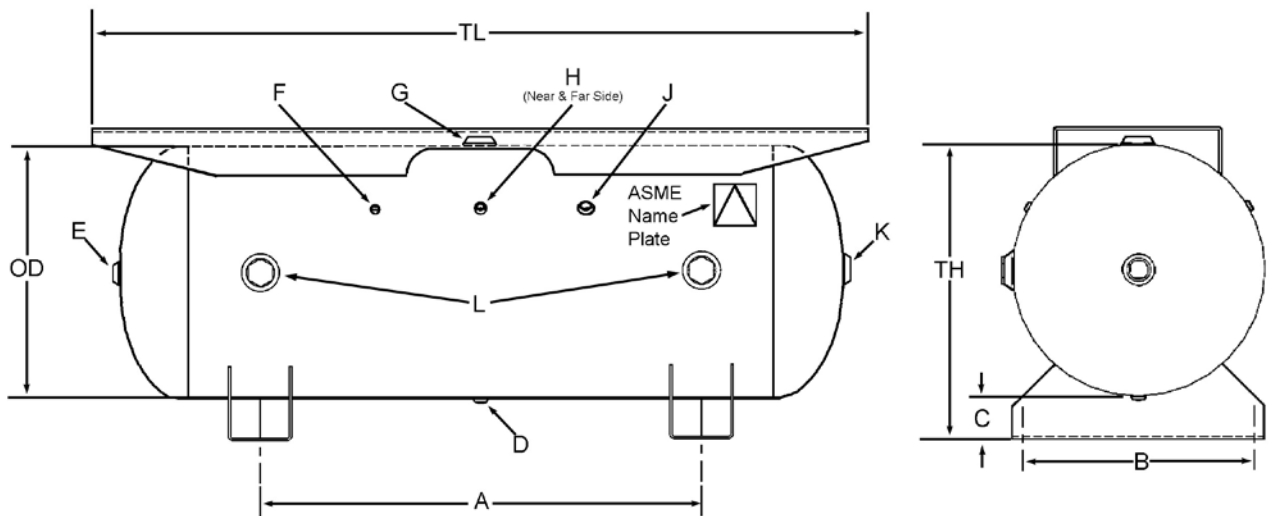

For your convenience, Manchester Tank's standard Pressure Vessel & Air Receiver drawings are available for download. Visit Manchester Tank's website at mantank.com

NOM CAP		Part #	MAWP	Top Plate	TW	DIMENSIONS IN INCHES						NPT OPENINGS							
Gal	Cu Ft					OD	TL	TH	A	B	C	D	E	F	G	H	J	K	L
30	4.01	302686	200	.18 x 12 x 40	117	16	38	20.63	22	14	3	1/4	1/2	3/8	3/4	1/4	1/4	3/4	1 1/2
60	8.02	302693	200	.25 x 16 x 54	216	20	48	25.56	26	18	4	1/2	1/2	3/8	1	1/4	1/4	1	2
80	10.70	303977	200	.25 x 16 x 69	375	20	63	25.63	36	18	4	3/4	3/4	3/8	1 1/2	1/4	1/4	1 1/4	2
120	16.04	302700	200	.25 x 16 x 74	475	24	69	29.63	42	22	4	3/4	1	3/8	1 1/2	1/4	1/2	1 1/2	2
200	26.74	302701	200	.25 x 18 x 86	706	30	72	35.75	42	28	4	1	1	3/8	2	1/4	1/2	2	2
240	32.09	303181	200	.25 x 18 x 86	728	30	84	35.75	54	28	4	1	1	3/8	2	1/4	1/2	2	2

Technical Aids

Vertical NEMA Frame Sizes

GALLONS	56	56H	143T	145T	182T	184T	213T	215T	254T
30	X	X	X	X					
60				X	X	X	X		
80				X	X	X	X		
120						X	X	X	X

Horizontal NEMA Frame Sizes

GALLONS	56	56H	143T	145T	182T	184T	213T	215T	254T
30	X	X	X	X					
60				X	X	X	X		
80						X	X	X	X
120						X	X	X	X

Air Receiver Capacity in Cubic Feet of Free Air at Various Pressures

CAPACITY		PRESSURE (in pounds)					
GALLONS	CU. FT.	75	100	125	150	200	250
30	4.0	4.0	27.3	34.2	41.0	54.7	68.3
60	8.0	8.0	54.7	68.2	82.0	109.4	136.7
80	10.7	10.7	73.0	10.7	109.4	146.0	182.4
120	16.1	16.1	109.3	92.2	164.0	218.7	273.3
200	26.8	26.8	182.2	136.2	273.4	364.5	455.6
240	32.2	32.2	218.7	227.8	328.0	437.4	546.7
400	53.6	53.6	364.5	455.6	546.7	729.0	911.2
660	88.4	88.4	601.4	751.7	902.1	1202.8	1503.4
1060	142.0	142.0	965.9	1207.3	1448.8	1931.7	2414.5
1600	214.4	214.4	1457.9	1822.4	2186.9	2915.8	3644.8
2560	343.0	343.0	2333.0	2916.0	3499.0	4655.0	5832.0

Capacities at other pressures are exactly in proportion.

Example: At 200 lbs. pressure the capacity of a given size tank is exactly double the capacity at 100 lbs. pressure.

$$\text{Gallons} = \frac{\text{Cu. Ft.}}{0.134} \quad \dots \quad \text{Cu. Ft.} = \text{Gallons} \times 0.134$$

Useful Formulas - Sizing a Tank

A Constant Speed Operation: $\text{Tank Size (ft}^3\text{)} = \frac{\text{Compressor Flow (CFM)}}{7}$

B Typical Sizing Formula: $VR = \frac{14.7 t (Q_r - Q_c)}{P_{\max} - P_{\min}}$ where

- t = time (min) that receiver can supply required amount of air,
- Q_r = consumption rate of pneumatic system (cfm),
- Q_c = output flow rate of compressor (cfm),
- P_{max} = maximum pressure level in receiver (psi),
- P_{min} = minimum pressure level in receiver (psi),
- V_r = receiver size (ft³)

C 7.48 Gallons = 1 ft³ Volume

D 14.5 psi = Bar

E 35 CFM = $\frac{1 \text{ Meter}^3}{\text{Min}}$

F Pump Up Time: Example - 5 hp compressor on an 80 gallon tank, pumping from 0-100 psig

$$\frac{80 \text{ Gallon Tank}}{7.5 \text{ gl./ft}^3} \times (100 \text{ psig} - 0 \text{ psig}) = \frac{1066.67}{14.7 \text{ (the ATM Pressure)} \times 18 \text{ (the CFM of Unit)}} = 4 \text{ min}$$

Vessel Installation and Maintenance Recommendations

I. INSTALLATION RECOMMENDATIONS

Vertical Vessels

1. Vessels with a capacity of 660 gallons and above should be placed on a suitable concrete foundation.
 - a) Refer to Table 1 for recommended minimum concrete footing depths for vertical receivers.
 - b) For larger vessels or vessels with higher MAWP's, greater weights, or vessels subjected to external seismic or wind loadings – consult a certified contractor or civil engineer for foundation requirements.
 - c) Vessels should be lifted into position using both lifting lugs. A 2-branch chain or wire rope sling should be used having a lift angle not less than 60 degrees from grade. Once the vessel is in position, torque anchor bolting until a tight, snug fit is achieved.

Table 1: Minimum Recommended concrete footing depths for Vertical Air Receivers

TANK SIZE	MAWP (PSI)	W.C. (GAL)	APPROX. WT. (LBS.)	SERVICE	SUPPORT	DEPTH (IN)
42" X 117"	165	660	1365	AIR	SKIRT	4
48" X 144"	165	1060	2100	AIR	SKIRT	4
54" X 166"	165	1550	2600	AIR	SKIRT	4
60" X 190"	165	2200	3650	AIR	SKIRT	4
60" X 220"	165	2560	4500	AIR	SKIRT	4
66" X 214"	165	3000	5700	AIR	SKIRT	6
72" X 228"	137	3800	6800	AIR	SKIRT	6

Horizontal Vessels

1. Vessels with a capacity of 660 gallons and above should be placed on a suitable concrete foundation.
 - a) Refer to Table 2 for recommended minimum concrete footing depths for horizontal receivers.
 - b) For larger vessels or vessels with higher MAWP's, greater weights, or vessels subjected to external seismic or wind loadings – consult a certified contractor or civil engineer for foundation requirements.

Table 1: Minimum Recommended concrete footing depths for Horizontal Air Receivers

TANK SIZE	MAWP (PSI)	W.C. (GAL)	APPROX. WT. (LBS.)	SERVICE	SUPPORT	DEPTH (IN)
42" X 117"	165	660	1365	AIR	SADDLE	3
48" X 144"	165	1060	2100	AIR	SADDLE	3
54" X 166"	165	1550	2600	AIR	SADDLE	3
60" X 190"	165	2200	3650	AIR	SADDLE	4
60" X 220"	165	2560	4500	AIR	SADDLE	4
66" X 214"	165	3000	5700	AIR	SADDLE	4
72" X 228"	137	3800	6800	AIR	SADDLE	6

Vessel Installation and Maintenance Recommendations

There should be at least one high quality pressure indicating device attached directly to an opening in the vessel.

A relief valve must be selected and installed. The valve must be sized according to the maximum flow rate into the vessel such that over-pressurization cannot occur. See ASME Section VIII, Division 1, Paragraph UG-125 for details on relief valves.

An automatic drain device is recommended to regularly drain any condensate from the vessel. In lieu of an automatic device, the user should be cautioned to regularly drain the receiver manually.

Notes: Reinforced concrete 28 day ultimate strength – 2500 psi minimum

Uniform gravel and soil base beneath footing. Footing surface shall be flat and level in all directions.

Anchoring the vessel to the concrete footing is necessary to stabilize the receiver only and is not intended to provide resistance against wind, seismic, or other external loadings that may create a vessel tipping condition. The above table represents footing depths for compressive loading only.

Check local construction codes, fire codes, or building standards.

Use an appropriately sized anchor bolt of SA-325 material or better, a wrought steel washer, and a heavy hex nut.

Footings exposed to freezing temperatures should be sufficiently sized in depth to prevent cracking.

Larger vessels not covered in the table, saddles may be provided which have holes on one end of the vessel and slots on the other end of the vessel. When bolting saddles to the foundation, anchor bolting should be fixed by first hand-tightening the nut and then locking the threads by staking, double nutting, or tack welding.

VESSEL MAINTENANCE

All Pressure Vessels

Maintaining a pressure vessel includes proper inspection. Many states have adopted the National Board Inspection Code (NB-23) for rules concerning post-construction activities. Check with your local authorities having jurisdiction over pressure vessel installations and operations for any additional requirements concerning in-service inspection.



Setting the Standard for Quality and Reliability



MANCHESTER TANK & EQUIPMENT CO., a division of McWane Inc., is the premier manufacturer of pressure vessels for the containment of propane, compressed air and chemical applications. Manchester Tank's mission is to set the industry standard for quality and reliability while providing customers with the resources, service and technical support necessary to be profitable in an increasingly competitive global market.

- Capable of manufacturing a diverse product line, which includes Department of Transportation (DOT) approved steel and aluminum cylinders ranging in size from 5 to 420 pounds and American Society of Mechanical Engineers (ASME) approved steel tanks ranging in size from 1 to 30,000 gallons.
- State-of-the-art manufacturing facilities and distribution points strategically positioned in the United States, Canada, Australia and the Republic of Chile to guarantee timely delivery and convenience worldwide.
- Strong business development group with extensive knowledge and experience in providing solutions and ensuring customer needs are met efficiently and cost effectively.
- Highly trained, professional engineering and design team prepared to support any organizations innovative tank and equipment requirements.
- Long-time, loyal partners also committed to customer satisfaction and overall success.
- Years of active involvement with American Society of Mechanical Engineers (ASME), Pressure Vessel Manufacturers Association (PVMA) and National Board of Boiler & Pressure Vessels Inspectors professional associations to ensure product, operations and manufacturing requirements and issues meet the codes and standards that impact the industry.



sales@mantank.com
mantank.com

Bedford, Indiana Customer Service

Phone: 800-399-5628
 Fax: 800-877-9988

Quincy, Illinois Customer Service

Phone: 800-926-2791
 Fax: 800-596-2284