

CODE/ADDENDA 2013 APPROVED DP  
 RELEASED FOR PRODUCTION  
 Q.C. \_\_\_\_\_ DATE \_\_\_\_\_

FIND NO.	NPT SIZE
F1	1/2
F2	3/4
F3	1
C1	3/4
C2	1/2

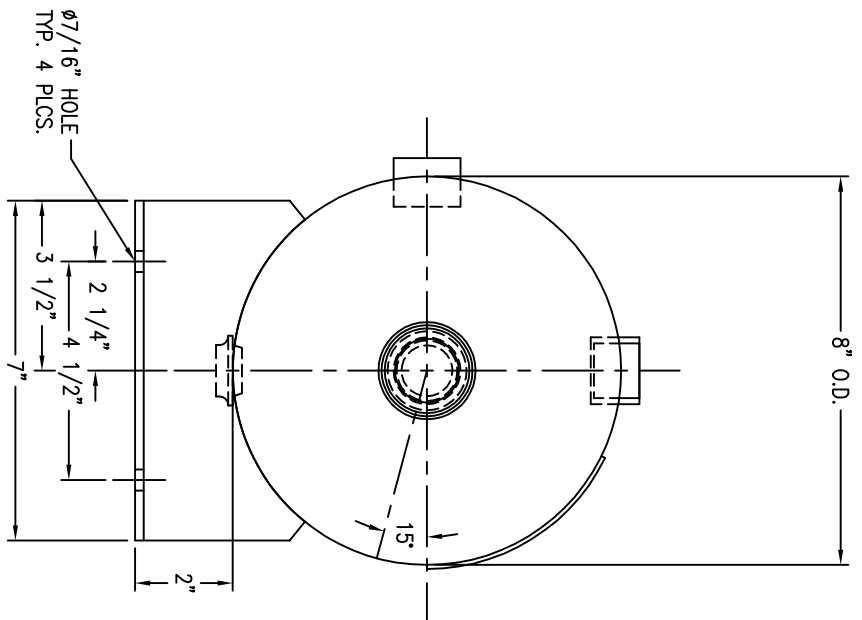
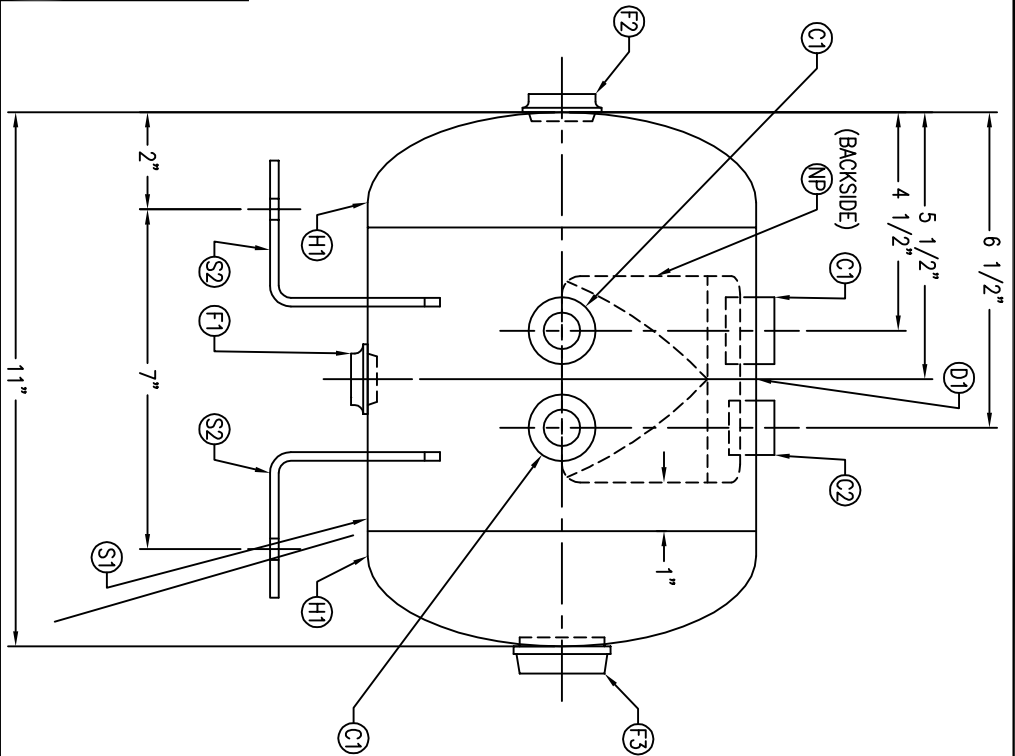

SYM	DATE	BY	REVISION
A		EGB	

APP	XREF	REV.
EGB	C1086	

NOTES  
 1. ALL PLUGS TO BE LOOSENED TO HAND TIGHT PRIOR TO SHIPMENT.

SPECIFICATIONS	
O.D. 8	LGTH. 11
MAMP 200 PSI @ 650 F.	SH. HD.
RT- MDMT -20 F @ 200 PSI	GAL. 2.0
EXMT TEST PSI	SA. 2.1
CRN H9635.5123467890	WT. 15#
	CULFT. .26
	CORR ALW
	CODE: ASME SEC. VIII DIV. I,
	LATEST EDITION & ADDENDA
	WELD DETAILS: M-1932
	STD. TOLERANCES (UNLESS OTHERWISE NOTED): M-2461



\\metrohdn.appsf\DWG\304

# HORIZONTAL AIR RECEIVER

DRAWN BY	DATE	SCALE:
EGB		NONE
APP. BY	DATE	DRAWING NO.
EGB		304980