KRSD Series
Rotary Screw Air
Compressor

Instruction
Manual

(Controller MAM-6090)

PN: 96002015000010

Release 2016, Version: A

TABLE OF CONTENTS

1. Safety Information.....	4
1.1 Safety Alert Symbols.....	4
1.2 Safety Precautions.....	5
1.3 Pressure.....	5
1.4 Fire and Explosion.....	6
1.5 Moving Parts.....	6
1.6 Hot Surfaces.....	6
1.7 Proper Compressed Air Applications.....	6
1.8 Electrical Shock.....	7
2. General Information.....	8
2.1 Introduction.....	8
2.2 The Compression Cycle.....	9
2.3 Compressor Lubrication and Cooling System.....	10
2.4 Compressor Discharge System.....	10
2.5 Air-end, Inlet Valve and Filtration System.....	11
3. Fluid Information.....	12
3.1 Fluid Guide.....	12
3.2 Fluid Change and Recommendations.....	13
4. Installation.....	14
4.1 Compressor Mounting, Support and Location.....	14
4.2 Ventilation and Cooling.....	14
4.3 Piping Connection.....	15
4.4 Fluid Level Inspection.....	16
4.5 Electrical.....	17
4.6 Motor Rotation Inspection.....	17
4.7 Fan Rotation Inspection	18
5. Operation.....	19
5.1 Routine Operation.....	19
5.2 Electronic controller basic operation.....	20
5.3 Program structure.....	23

5.4	Technical parameters.....	41
5.5	Alarms.....	43
6.	Servicing.....	44
6.1	Fluid Change.....	44
6.2	Air Filter.....	44
6.3	Fluid Filter.....	45
6.4	Air/Oil Separator.....	45
6.5	Fluid sampling procedure.....	45
6.6	Maintenance Schedule.....	46
7.	Troubleshooting Guide.....	48
8.	Standard Terms and Conditions	51

Safety Information

Thank you for choosing Kaishan Compressor. Please read this instruction manual carefully before using the compressor. This manual must be kept in the safe place for future reference. Kaishan Compressor's authorized distributors provide maintenance service for KRSD series rotary screw compressors. A certified technician is required to ensure compressors maintenance is safely handled. By following the instructions in this manual, the user will minimize possibility of an accident throughout the useful life of this equipment.

1.1 SAFETY ALERT SYMBOLS

Key hazards are used throughout this manual. The level of hazards seriousness is symbolized as follows:



This symbol identifies immediate hazards which **will** result in severe personal injury, death or substantial property damage.



This symbol identifies hazards or unsafe practices which **could** result in personal injury, death or substantial property damage.



This symbol identifies immediate electrical hazards which **will** result in severe personal injury, death or substantial property damage.



This symbol identifies hazards or unsafe practices which **could** result in personal injury or substantial property damage.



This symbol identifies immediate hot surface hazards which **will** result in severe personal injury.



Identifies important installation, operation or maintenance information which is not hazard related.

1.2 SAFETY PRECAUTIONS

This manual describes the safety precautions, structure, and functions of all systems and components, as well as the operation and maintenance methods for the KRSD series rotary screw air compressors. The owner and operator shall read the manual carefully. Only after thorough understanding should the machine be operated for the first time. This manual gives you a general description of the mechanical and electrical systems and maintenance. However, if you have any questions about operating and maintenance of the compressor, please contact your authorized distributor or our service department personnel.

Do not modify the compressor and/or controls in any way except with written factory approval. While not specifically applicable to all types of compressors with all types of prime movers, most of the precautionary statements contained herein are applicable to most compressors and the concepts behind these statements are generally applicable to all compressors.



Failure to follow any of these precautions may result in severe personal injury, death, property damage and/or compressor damage

1.3 PRESSURE

A properly sized pressure relief valve must be installed in the discharge piping ahead (upstream) of any shutoff valve (block valve), heat exchanger, orifice, or any potential blockage point. Failure to install a pressure relief valve could result in the rupturing or explosion of some system components. Relieve all pressure internally to the compressor prior to servicing. Do not depend on check valves to hold system pressure. Do not change the pressure setting of the pressure relief valve, restrict the function of the pressure relief valve, or replace the pressure relief valve with a plug. Over pressurization of system or compressor components can occur resulting in death, severe personal injury, or property damage. Do not operate the compressor at pressures in excess of its rating. Never use plastic pipe, rubber hose, or soldered joints in any part of the compressed air system. Failure to ensure system compatibility with compressor piping is dangerous

1.4 FIRE AND EXPLOSION

Clean up any spills of lubricant or combustible liquid immediately. Keep sparks and flame away from the compressor. Do not permit smoking during servicing, such as checking or adding fluid. Wipe down spills immediately using industrial cleaner as required. Do not use flammable material for cleaning purposes. Do not operate the compressor in a hazardous environment unless the compressor has been specially designed for that environment. Wear personal protective equipment including safety goggles and clothing during servicing the compressor. Never use a flammable or toxic solvent for cleaning the air filter or any parts.

1.5 MOVING PARTS

Keep hands, arms and cloths away from the coupling and fans of the compressor. Do not remove any guards or cabinet panels or attempt to service any compressor part while the compressor is operating.

1.6 HOT SURFACES

Do not touch any hot surface and parts during the compressor's operation. Keep all body parts away from air/oil receiver tank, steel tubing, air end and after-cooler. Wear personal protective equipment including gloves while servicing the compressor.

1.7 PROPER COMPRESSED AIR APPLICATIONS

Air from this compressor will cause severe injury or death if used for breathing or food processing. Air used for those processes must meet OSHA and applicable industry regulations. This compressor is designed for use in the compression of normal atmospheric air only. No other gases, vapors or fumes should be exposed to the compressor intake, nor processed through the compressor. Keep personnel away from the compressed air discharge. Use compressed air for cleaning purpose only with effective chip guarding and personal protective equipment which meet OSHA standard and/or any federal, state, local codes, standard and regulation.

1.8 ELECTRICAL SHOCK

Never start the compressor unless it is safe to do so. Do not attempt to operate the compressor with a known unsafe condition. Tag the compressor and render it inoperative by disconnecting and locking out all power at the source or otherwise disabling its prime mover so others who may not know of the unsafe condition cannot attempt to operate it until the condition is corrected. Install, use and operate the compressor only in full compliance with all pertinent OSHA regulations and/or any applicable Federal, State, and Local codes, standards and regulations. Never assume it is safe to work on the compressor because it is not operating. Many installations have automatic start/stop controls and the compressor may start at any time.

- Follow all maintenance procedures and check all safety devices on schedule.



- Use the correct compressor fluid at all time

- Do not rely on the discharge check valve to isolate the compressed air service line

NOTICE

- Keep panels closed at all times, and stay away from hot surfaces to prevent hazards



NOTICE

These instructions, precautions and descriptions cover KRSD series air compressors. As a service to our customers, we often modify or construct packages to the customer's specifications. This manual may not be appropriate in those cases.

Every effort has been taken to ensure complete and correct instructions have been included in this manual. However, possible product updates and changes may have occurred since printing this manual. Kaishan Compressor USA reserves the right to change specifications without incurring any obligation for equipment previously or subsequently sold.

General Information

2.1 INTRODUCTION

The KRSD series offer models with power ranging from 30 hp to 50 hp. These direct driven compressors have standard full load pressure rating from 100 psi to 175 psi (7 bar to 13 bar). The compressor is a single stage, positive displacement, fluid-flooded rotary screw. A complete package consists of following:

- Compressor (Air End)
- Electric motor
- Starter
- Air Inlet System
- Compressed air Discharge System
- Lubrication and Cooling System
- Capacity Control System
- Instrumentation Panel
- Air and Fluid Cooling System
- Air/ Fluid separation tank (Reservoir)

All components are assembled on a structural steel base with enclosure. The control panel is located in the front of the enclosure door panel. Acoustical enclosure is one of the standard features for all compressors.



Dismantling the compressor's enclosure may void its warranty.

NOTICE!

2.2 THE COMPRESSION CYCLE

The compressor housing contains of two rotors; Male and Female rotors. The male rotor has five lobes and female rotor has six flutes. They are constantly and precisely meshed, and housed in the cylinder with two parallel adjoining bores. All parts are machined to exacting tolerances. The rotors provide positive-displacement internal compression smoothly and without surging. As the rotors rotate, air is drawn into the cylinder through the inlet port. A volume of air is filled and trapped as the rotor lobes pass the inlet port in the cylinders. Compression occurs as the male rotor rolls into the female flute, progressively reducing the space thereby raising the pressure. Compression continues until the lobe and flute pass the discharge port. The compressed air is then discharged into the air/oil separator tank. There are five complete compression cycles for each complete rotation of the male rotor.

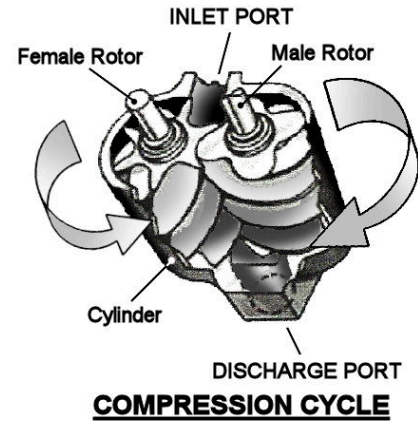

When the compressor is operating, a partial vacuum is produced at the compressor inlet. Fluid is injected into the compressor unit and mixed with the air. The fluid has three basic functions:

- As a coolant, it controls the rise in air temperature normally associated with the heat of compression.
- It seals the leakage paths between the rotors and stator and also between the rotors themselves.
- It acts as a lubricating film between the rotors allowing one rotor to directly drive the other, which is an idler.

After air/fluid mixture is discharged from compressor to the reservoir, fluid is separated from the air in the separator tank. Compressed air then flows through the after-cooler for moisture removal while the lubricant is being cooled by the fluid-cooler for re-injection.

2.3 COMPRESSOR LUBRICATION AND COOLING SYSTEM

The lubrication and cooling system consists of a reservoir, centrifugal fan, fan motor, aluminum finned fluid-cooler and after-cooler, thermal valve & fluid filter. High pressure forces the lubricant through a series of direction changes in the reservoir where it is separated from the air. The fluid is then delivered to the thermal valve and fluid-cooler. Cooled fluid will be filtered before being re-injected back into the compressor.

Ambient air is being forced through the cooler fins by the centrifugal fan, which cools the fluid and compressed air in the cooler tubes. The after-cooler helps separate the water content in the discharge air, and through the automatic condensate drain, the water will be drained. This avoids water contamination problems downstream (in service lines). Cooler fins must be kept clean at all times.

Fluid from reservoir circulates to the thermal valve. The thermal valve is fully closed when the fluid temperature is below 70°C (158°F). Fluid (below 158°F) will bypass the thermal valve and inject directly to the aircend. As the discharge temperature rises above 80°C (176°F), due to heat of compression, the thermal valve begins to open and fluid will be circulated to the cooler.

2.4 COMPRESSOR DISCHARGE SYSTEM

Air/fluid mixture has been forced into reservoir after compression. The reservoir has two basic functions:

- It acts as a primary fluid separator.
- It serves as the compressor fluid sump.

The compressed air/fluid mixture enters the reservoir and is directed against the internal baffle. Turbulent flow occurs, and velocity is significantly reduced, thus causing large droplets of fluid to form and fall to the bottom of reservoir. Fluid collected in the reservoir will then be returned to the compressor due to the pressure differential.

The sight glass enables the operator to visually monitor the reservoir fluid level. Fluid is added to the reservoir by removing the fluid filling cap after all system pressure is relieved. The fluid level should remain at the top red lines on the sight glass. Fluid refill is required once its level drops below the lower red line.

The minimum pressure check valve assures the reservoir maintains a minimum pressure between 58 psig and 72 psig (4Bar and 5Bar) during unloading conditions. This pressure is necessary for air/fluid separation and fluid circulation.

2.5 AIREND, INLETVALVE AND FILTRATION SYSTEM

The compressor inlet system consists of a air filter, inlet valve. & **SKK** airend. The inlet valve controls the air intake volume. It is also acts as the check valve to prevent the reverse pressure and rotation when compressor is shutting down.

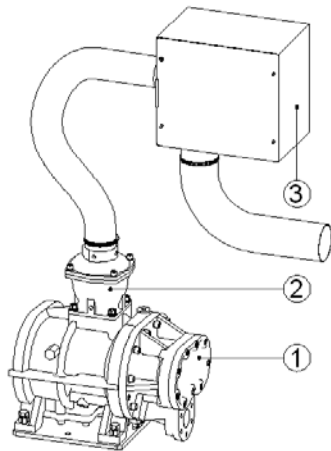

①	Air end
②	Inlet valve
③	Casing for air filter

Fluid Information

3.1 FLUID GUIDE

KRSD compressors are filled & tested with Kaishan lubricant. Refer *Figure 3-1* for filler port, sight glass, quarter-turn valve location on the reservoir. The compressor is filled with the manufacturer's recommended quantity of Kaishan fluid. Inspection of the reservoir fluid level during installation or operation is recommended.

①	Air/Oil Separator Tank
②	Fluid Fill Port
③	Sight Glass
④	Fluid Drain Valve

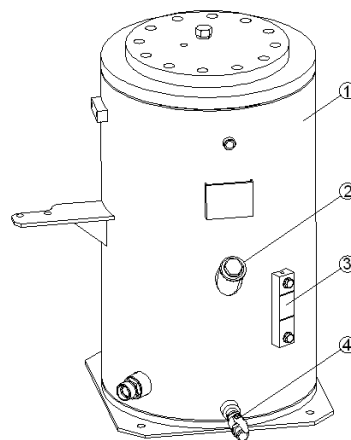

Figure 3-1: Fluid Fill Location



Do not use different fluid. Using different fluid will void compressor's warranty.

3.2 FLUID CHANGE RECOMMENDATIONS

LUBRICANT	FLUID CHANGE	FLUID FILTER CHANGE	SEPARATOR CHANGE
KTL8000	Every 8,000 hours or as indicated by sampling report	Every 2,000 hours or as indicated by Delta P	Every 8,000 hours (4,000 hours for "spin on" type separator) or as indicated by Delta P
KTL4000 FG	Every 4,000 hours or as indicated by sampling report	Every 2,000 hours or as indicated by Delta P	Every 8,000 hours (4,000 hours for "spin on" type separator) or as indicated by Delta P

Installation

4.1 COMPRESSOR MOUNTING, SUPPORT AND LOCATION

Compressor should be located on a flat surface in a clean, well-lit and well-ventilated area. The location must have sufficient access for maintenance equipment and lifting vehicle. Four feet (4') of clearance around the compressor is recommended for daily inspection and easy access to all compressor components. The area must have sufficient lighting for technicians to safely operate the compressor as well as perform maintenance work. The location should be free from standing water.

The compressor's base must be installed on a level surface that can support the gross dead weight of the machine. Rubber pads with 5 - 15mm thickness or pliable material should be placed under the bottom of the base if floor surface is uneven or irregular. A stationary compressor will prevent accidents such as broken piping or electrical connections.



Brand new compressor has “Orange Color” shipping bracket installed under airend assembly. Please remove the bracket after the unit is installed.

NOTICE!



Removal or paint over of safety labels will be a safety hazard. This could result in personal injury or property damage. Warning signs and labels should be conspicuous and on a bright legible surface. Do not remove any warning, caution or instructional material attached with unit.

4.2 VENTILATION AND COOLING

Ambient temperature should not exceed 40°C (104°F). High ambient temperatures may result in high air temperature shutdown.



Do not install and operate compressor if the ambient temperature is below 2°C (35°F). Severe ambient modifications must be installed with the unit for lower ambient temperatures.

NOTICE!

The compressor air inlet must be located in the opposite direction to other compressors or heat generating equipment. The object is to avoid hot air being drawn into the system. Do not block the exhaust air from cooler or fan. Hot exhaust air must be vented outside through a duct to prevent high ambient room temperature. The compressor room must be properly ventilated to avoid compressor high temperature shutdown.



Maintain clean & fresh air, dust free, metal particle free and chemical vapor free in the compressor's room. Housing the compressor within a poorly ventilated enclosure will cause higher operating temperature.



Under no circumstances should a compressor be installed in an area exposed to toxic, volatile or corrosive atmosphere, nor should toxic, volatile or corrosive agents be stored near the compressor.

All models are intended for indoor installation; however, it is possible, with certain modifications, to accommodate some outdoor locations. Models with standard enclosure are water-resistant but not water tight. Shelter is needed to protect the unit from rain, snow and freezing temperatures. An optional weather hood or air grille could be installed to protect compressor against blowing rain and snow as well as cabinet heater additions if ambient temperature will be below 2°C (35 F).

4.3 PIPING CONNECTION

Before installation, review the complete air systems layout, which includes compressor(s), receiver tank, dryer(s), line filter(s), pipe size, water drain and isolator valves. Never join pipes or fittings by soldering. Never use PVC pipe or non-genuine rubber hose in the air system. Use flexible connections to prevent pipe load from being transmitted to the compressor. Never use a different pipe size other than the manufacturer specification for the compressor unit.

A service line shut off valve must be installed after the compressor air outlet connection with a pressure relief valve installed to release compressed air to the atmosphere. For a single compressor and air receiver tank, manual shut off valves are typically being installed. A union connector must be installed after the ball valve (quarter turn, shut off valve) at the compressed air outlet. This will allow unit isolation for maintenance.



Make sure system pressure is relieved by confirming that sump pressure gauge is reading zero prior to servicing. Failure to relieve system pressure could result in death or serious injury and property damage.

A receiver tank should be installed if compressed air demands fluctuate. Service line piping is recommended to be sized to match the compressor's discharge connector. All piping & fittings should be rated to withstand greater pressure than the discharge pressure. Isolation valves & drain valves are installed to isolate the compressor when service is required. These valves should have water drip legs with the drain direction facing downward to the floor. Piping should all line up properly with an adequate loop radius or bend radius given for easy installation and to prevent bending stress, flow restriction and damage due to thermal expansion. Piping support brackets must be mounted independent of the compressor and motor. This will avoid damage caused by vibration.

Pressure relief valves are sized to protect the system. Never change the pressure setting or tamper with the valve. Only the valve manufacturer and their authorized representatives are allowed to make such changes.



Pressure relief valves are used to protect system integrity in accordance with safety standards. Failure to provide properly sized valves will result in death or serious injury.

Pressure relief valves are installed prior to any potential blockage point such as shutoff valves, heat exchangers and discharge silencers. Ideally, the valve should be threaded directly into the pressure point it is sensing, not connected with tubing or pipe. Always direct discharge from relief valves to a safe area away from personnel.

4.4 FLUID LEVEL INSPECTION

Inspect the fluid level when the compressor is in shut down mode. Fluid level is indicated on the reservoir sight glass. The maximum fluid level is at the top red-mark. Add fluid until the top red-mark is reached.

4.5 ELECTRICAL

Before installation, the electrical supply should be checked for adequate wire size and capacity. User must comply with national & local electrical codes. The codes specify the surrounding clearance requirement for the electrical panel. Wiring work should be undertaken only by a qualified electrician in compliance with OSHA, national or local electrical code. KRSD compressor includes wiring diagrams for user reference. Refer to the electrical control schematic in the parts manual for wiring diagrams. A dedicated and fused disconnect switch or circuit breaker should be purchased for the installation. Any unreasonable voltage imbalance (5%) between phases must be eliminated and low voltage problems must be corrected to prevent excessive current draw. Air compressors must be grounded in accordance with applicable codes, regulations and requirement.



Kaishan Compressor would like to emphasize the importance of providing adequate grounding for air compressors. The common practice of grounding units to a building's structural steel may not provide adequate grounding protection, as paint and corrosion build-up may exist.



All electrical supply cables must be adequately sized to prevent overheating due to current draw.



Enclosure panels and drive grille must be fastened in place before starting the compressor and never removed before lock out / tag out of the main power supply.

A knock out hole is provided for an incoming power connection. If a different location for the starter hole is needed, the certified technician must make sure to keep control box clean after the hole is created. The original hole must be capped if another hole is used. Inspect incoming voltage to match the compressor's specification. Inspect motor starter and overload heater sizes. Check electrical connections L1-L2-L3 for tightness and cleanliness.

4.6 MOTOR ROTATION INSPECTION

Motor rotation must be checked after the wiring has been installed. Operating the compressor in incorrect rotation will result in severe damage to the compressor and warranty coverage will be voided. Motor rotation can be viewed through the opening in the drive grille. The drive motor end of the compressor is marked with an arrow noting the proper rotation.

To inspect rotors rotation, pull out the “EMERGENCY STOP” button and press once, quickly press the “START” and “STOP” button in sequence, allowing the motor to turn 2 or 3 revolutions. Observe the drive shaft for correct direction. If reverse rotation is observed, disconnect the power supply, reverse power input leads at the motor starter. Recheck for proper rotation.

4.7 FAN ROTATION INSPECTION

Fan motor rotation should be inspected. KRSD compressors use an axial fan for cooling. Fan rotation is inspected through an arrow shaped observation hole above the fan motor. The fan must rotate in the direction indicated by the arrow.



Always inspect fan rotation through the observation hole. Never assume the fan rotation is correct based on the induced air flow across the coolers. A centrifugal fan can pull the airflow across the coolers when rotating in either direction;

NOTICE! however, incorrect rotation will cause high discharge temperature.

Operation

5.1 ROUTINE OPERATION



Provisions should be made to have the instruction manual readily available to the operator and maintenance personnel. If, for any reason, any parts of the manual become illegible or if the manual is lost, have it replaced immediately. The instruction manual should be read periodically to refresh one's memory. This may prevent a serious accident.

Before compressor start up, inspect fluid level in reservoir. After start up, observe the control panel screen for operation status. Ensure the compressor is running at its optimum level.

Close the service valve to plant air distribution system. Allow pressure to build up within the reservoir until compressor fully unloads. Press the stop button.



NOTICE

Always close the service valve when compressor is not being used. It prevents back pressure from the service line and avoids leakage due to check valve failure.



NOTICE

Emergency shutdown. Press the emergency stop button or pull the circuit breaker at the main power terminal.

Operation

5.2 BASIC OPERATION

5.2.1. Screen display and basic operation

Power up screen:



Boot up screen, after 5 seconds:



Normal display screen:



- Line Pressure
- Discharge Temperature
- Current
- Voltage
- Fan Status
- Compressor Status
- Total Run Hours
- Total Load Hours

Icon touch screen display:



- Run Parameters
- User Parameters
- Factory Parameters
- Calibration Set
- Sequence Parameters
- Configuration Parameters
- Maintenance Parameters
- VSD Settings
- Touch Calibration
- Schedule Setup
- Schedule Activate
- Fault History
- Motor VSD
- Fan VSD
- Date and Time Set
- Return

Controller LED indication



Power: Is on when controller is powered on.



Run: Is on when motor is running.

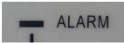

Alarm: Is blinking when compressor is alarmed. Is on when compressor is alarmed and stopped. Is off when errors have been cleared and reset.

5.2.2 Push button functionality



Push to Start Compressor.

When in Sequence Mode and Master Compressor, push to activate the Sequence Mode.



Push to Stop Compressor.

When in Sequence Mode and Master Compressor, push to de-activate the Sequence Mode.



Push to Load and Unload compressor when in running state.

Push to save data when modifying text box.

When on Icon Page, push to execute corresponding function.



When Controller in Alarm, press and hold for 5 seconds to Reset.

Push this button to allow data in textbox to be modified.

Push to return to previous menu.



Moves the cursor to the left.

On Icon page press to move back to next Icon.



Moves the cursor to the right.

When on the Icon page press to move to the previous Icon.



When on Icon page press to move down to next row.

When modifying values press to decrease.

When viewing RUN data press to scroll down to next page.



When on Icon page press to move up to next row.

When modifying values press to increase.

When viewing RUN data press to scroll up a page.

5.2.3 Icons display and functions



If activated, the following Icons will appear on the Normal Run Screen:



A Time Schedule has been set.



A Pressure Schedule has been set.



Auto Restart is engaged.

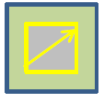

Remote Stop/Start activated.



Computer Visualization set.



Multi-Unit Sequence Control activated.

5.3. Program structure

Controller has 14 specific data zones; each zone is password protected. Other than RUN and USER PASSWORDS, only authorized and trained personnel should have access to other specific zones.

FUNCTION	PASSWORD
RUN	NO PASSWORD REQUIRED
USER	9999
FACTORY	****
CALIBRATION	****
SEQUENCE CONTROL	****
REMOTE SIGNALS	****
MAINTENANCE	6842
INVERTER SET	****
TOUCH SCREEN CALIBRATION	****
SCHEDULE SETUP	****
SCHEDULE ON/OFF	****
HISTORY FILE	****
MOTOR VSD	****
FAN VSD	****

5.3.1 Run menu

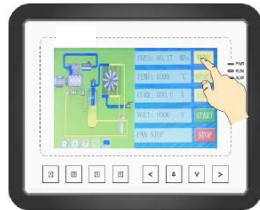

Press menu



Press RUN PARA

MENU	VALUE	FUNCTION
Air Pressure	00.80MPa	Display air pressure
Discharge Temperature	0075°C	Display discharge temperature
System Pressure	00.75MPa	Display system pressure
Oil Pressure Differential	00.55MPa	Display oil pressure differential
Front Rotor T	0065°C	Display front rotor temperature
Rear Rotor T	0065°C	Display rear rotor temperature

Oil Filter	OO20H	Display Running Time of Oil Filter Element
Air/Oil Separator	OO20H	Display Running Time of Air/Oil Separator Element
Air Filter	OO20H	Display Running Time of Air Filter Element
Lube	OO20H	Display Running Time of Compressor Lubricant
Grease	OO20H	Display Running Time of Main Motor Grease
Serial Number	123456789	Compressor serial number
Drain Close Time (S)	OO60	Time set for Condensate Drain to stay closed
Motor current	A: 000.0A B: 000.0A C: 000.0A	Display motor current
Fan current	A: 000.0A B: 000.0A C: 000.0A	Display Fan current
Production Date:		Build Date
This run time	0000:00:00	Display Total run hours
This load time	0000:00:00	Display Total load hours
Software		Revision number
Check 1: 0000 0000		Check 2: 0000 0000
Digital inputs	1 2 3 4 5 6 7 8 9 10	
	o o o o o o o o o o	
	1: Refer to Digital Input 24	Emergency Stop
	2: Refer to Digital Input 23	Multi Functional
	3: Refer to Digital Input 22	Low Water Flow
	4: Refer to Digital Input 21	Oil Filter DP
	5: Refer to Digital Input 20	Separator DP
	6: Refer to Digital Input 19	Air Filter DP
	7: Refer to Digital Input 18	Multi Functional
8: Refer to Digital Input 17	Remote On/Off	
Digital outputs	1 2 3 4 5 6 7 8 9 10	
	o o o o o o o o o o	
	1: Refer to Digital Input 43	Emergency Stop
	2: Refer to Digital Input 42	Multi Functional
	3: Refer to Digital Input 41	Low Water Flow
	4: Refer to Digital Input 40	Oil Filter DP
	5: Refer to Digital Input 39	Separator DP
	6: Refer to Digital Input 38	Air Filter DP
	7: Refer to Digital Input 36	Multi Functional
	8: Refer to Digital Input 33	Compressor Running
9: Refer to Digital Input 32	Compressor Fault	
10: Refer to Digital Input 31	Compressor Alarm	
Motor Rated Speed	OOOO RPM	Display Motor actual RPM based on the calculation of motor frequency read
Motor Rated Power	OOO.O Hz	Display Inverter output Frequency
Motor Output Current	OOO.O A	Display Inverter Output Current
Motor Output Voltage	OOO.O V	Display Inverter Output Voltage

Motor Output Power	000.0 KW	Display Inverter Output Power
Motor Power Consumption	000.0 KW/Hr	Display Power Consumption in Real Time
Motor Power Total Consumption	000.0 KW/Hr	Display accumulative Power Consumption
Motor State Description	0000	Motor Running Status From Inverter data read
Error Description	0000	Motor Error Status from Inverter data read
Write Frequency	000.0	Motor Frequency based on PID calculations
Fan Speed	0000 RPM	Real Time Cooling Fan Speed based on frequency read
Fan Output Frequency	000.0 Hz	Display Output Frequency of Cooling Fan Inverter
Fan Output Current	000.0 A	Display Output Current of Cooling Fan Inverter
Fan Output Voltage	000.0 V	Display Output Voltage of Cooling Fan Inverter
Fan Output Power	000.0 KW	Real Time Cooling Fan Power from Inverter
Fan Power Consumption	000.0 KW/Hr	Display Fan Power Consumption in Real Time
Fan Power Total Consump.	000.0 KW/Hr	Display accumulative Fan Power Consumption
Fan State Description	0000	Fan Running Status from Inverter data read
Error Description	0000	Fan Error Status from Inverter data read
Write Frequency	000.0	Fan Frequency on PID calculations
PF Motor ϕ UI	000000.OVA	Display Motor Real Time kW
PF Motor This Elec.	000.0 KW/Hr	Display motor Real time power consumption
PF Motor Total Elec.	000.0 KW/Hr	Display motor Total run power consumption
PF Fan ϕ UI	000000.OVA	Display fan Real time KW
PF Fan This Elec.	000.0 KW/Hr	Display fan Real time power consumption
PF Fan Total Elec.	000.0 KW/Hr	Display fan total run power consumption

5.3.2 User menu

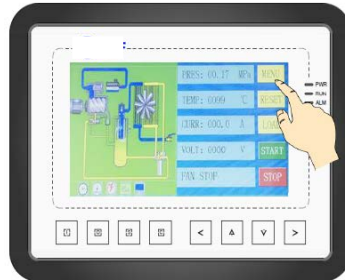

Press MENU



Press USER PARA

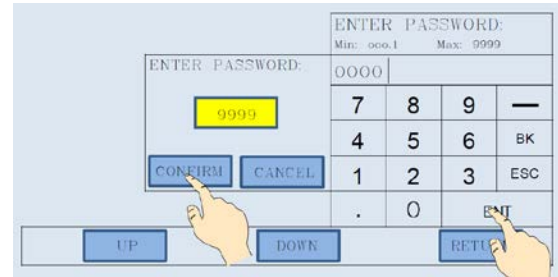
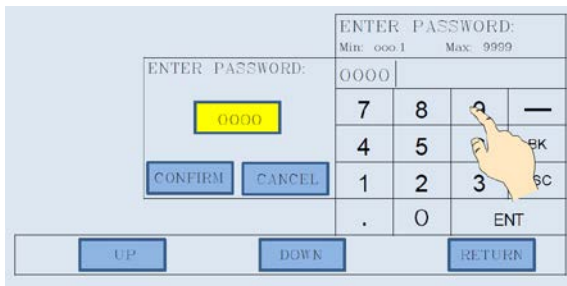

Enter the User password, press Enter and Confirm.

MENU	DEFAULT VALUE	FUNCTION
Load Pressure (MPa/PSI)	00.65/94.30	Load Pressure
Unload Pressure (MPa/PSI)	00.80/116.00	Unload Pressure
Fan Start T (°C/°F)	0080/176	Fan will start if Discharge Temperature is above this setting
Fan Stop T (°C/°F)	0070/158	Fan will stop if Discharge Temperature is below this setting
Motor Start Delay (S)	0008	Set to bypass Motor Overload protection on start up, the value here must be longer than the STAR DELAY TIME plus LOAD DELAY TIME
Fan Start Delay (S)	0003	Set to bypass Fan Motor Overload protection on start up
Star Delay (S)	0006	Star Delta changeover time
Load Delay (S)	0002	Delay to load after start running in Delta
Standby Delay (S)	0600	Compressor will stop after running continuously

		unloaded over this time
Stop Delay (S)	0010	Run on time after Stop Button pressed
Restart Delay (S)	0100	Will stop compressor from starting for the duration of this setting
Drain Open Time (S)	0002	Time set for Condensate Drain to open and purge
Drain Close Time (S)	0060	Time set for Condensate Drain to stay closed
Soft Start Delay (S)	0006	Controller starts Load delay time after this time setting
Load Mode	Manual/ Automatic	Manual Mode; Use Load/Unload Button. If pressure is above unload pressure compressor will unload automatically. Automatic Mode; Will load and Unload via Pressure Transducer.
Start Mode	Local/ Remote	Stop and start from MAM Controller/ Will start from MAM Controller and remote contacts
Run Mode	5 options	DOL, Motor VSD, Fan VSD, Motor Fan VSD, Soft Start
Comm Address	0001	Set the Communication address in Computer or Sequence Mode
Backlight Adjustment	0001	Set Controller backlight Level 1 - 4
Comm Mode	3 Options	Disable ~ Comm function not activated. Computer ~ Comm with computer or DCS with Modbus RTU Baud Rate 9600 Data Format 8NI Parity Bit. Even Sequence ~ Compressors work in a net.
Pressure Units	3 Options	MPa ~ PSI ~ Bar
Temperature	2 Options	°C or °F
Language	4 Options	English ~ Chinese ~ German ~ Spanish
User Password	****	Change User Password.
Sleep Backlight	0007	Turn off backlight if not in operation.
System P Delay	0060S	Check whether the system pressure is lower than the set low system pressure stop value after start delay lasts for this time.

To change a setting:

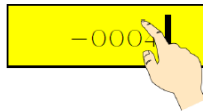
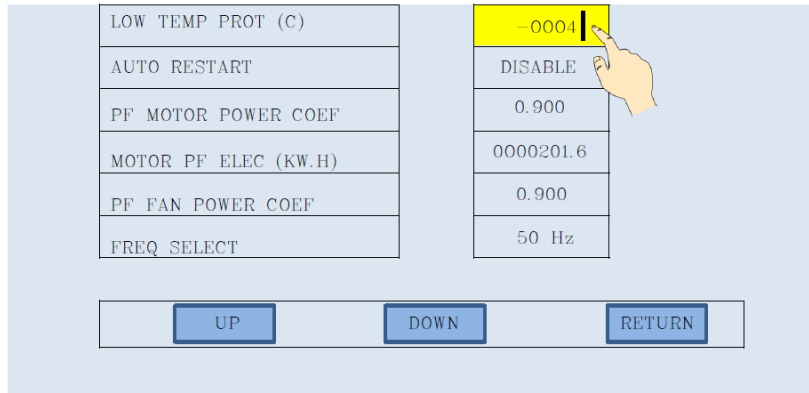

Highlight text to be modified



Press C to allow data modification – text will start flashing



Scroll values up or down



P Press S to set

5.3.3 Factory menu

Press MENU, Press FACTORY PARA, enter the password, press Enter and Confirm.

MENU	DEFAULT VALUE	FUNCTION
Motor Rated Current (A)	Max motor overload data/1.2	When the current of motor is more than 1.2 times the set data, the unit will stop for overload.
Fan Rated Current (A)	Max fan overload data/1.2	When the current of fan motor is more than 1.2 times the set data, the unit will stop for overload.
Discharge Temperature Alarm (°C/°F)	O105/0221	Discharge temperature alarm.
Discharge Temp trip (°C/°F)	O110/0230	Discharge Temperature Trip.
Front Bearing Alarm	O105/0221	Drive Bearing Temperature Alarm.

(°C/°F)		
Discharge Bearing Alarm (°C/°F)	O105/0221	Discharge Bearing Temperature Alarm.
Front Bearing Trip (°C/°F)	O115/0239	Drive Bearing Temperature Trip.
Discharge Bearing Trip (°C/°F)	O115/0239	Discharge Bearing Temperature Trip.
Stop Overpressure (Mpa/PSI)	OO.90/130.50	Will trip if pressure reaches this value.
System Stop P (Mpa/PSI)	O1.00/145.00	Will Trip if system pressure reaches this value.
Unload P Limit (Mpa/PSI)	OO.85/123.30	Maximum Permitted unload P.
Current imbalance	0006	Current Imbalance must be Set less than 15%, if ≥ 15 protection will be disabled.
Open Phase Protection (s)	002.0	Must be Set less than 20 Seconds, if ≥ 20 protection will be disabled.
Fault History Reset	8888	Input 8888, Press Set and all History will be Deleted.
Alarm Long Stop (H)	0000	When controller detects oil filter, air filter, O/A separator, lubricant or grease running over the max time and alarm over the data set, compressor will alarm and stop.
Max Run Time	0000	When the compressor is in a stop status and the TOTAL RUN TIME is over this MAX TIME set, compressor will alarm and stop, reporting USER MISTAKE. Set the data to 0000, this function is not activated.
Factory Password 2		Change Factory Password.
High Voltage (V)	O410	Will Trip if Voltage is Higher than Setting, if set at 0000 function is disabled.
Low Voltage (V)	O350	Will Trip if Voltage is Lower than Setting, if set at 0000 function is disabled.
VSD Comm Overtime (S)	002.0	MAM to Inverter Signal/Feedback.
VSD Comm Interrupt (S)	0020	If No Feedback MAM to Inverter VSD will Trip.
VSD Comm Restore (S)	0015	Will Restore Inverter Comm after interrupt.
Schedule On/Off	Disable/Enable	Set to Enable or Disable Time Schedule.
Set P Section	Disable/Enable	Set to Enable or Disable Pressure Schedule.
Total Run Time	000100 H;OOM	Change Total Run Time.
Total Load Time	000095 H;OOM	Change Total Load Time.
Low Temp Protection (°C/°F)	-0050/-0058	After power on, if the temperature is detected lower than the set data, it is not allowed to start. Two minutes after power on, if the temperature is detected lower than the set data, it is reported temperature sensor fault and stop.
Auto Restart	Disable/Enable	Will Restart Compressor after Power Failure if Enabled.
PF Motor Power Coefficient	1.72	Set to Calculate Motor Power.

Motor PF Power Consumption (KwH)	000000.0	Set and Modify the Motor Power Consumption in PF Mode.
PF Fan Power Coefficient	1.72	Set to Calculate Fan Power.
Fan PF Power Consumption	000000.0	Set and Modify the Fan Power Consumption in PF Mode.
Frequency Select (Hz)	60	Set Frequency.
Oil Pressure Diff Alarm (Mpa/PSI)	00.15/21.75	On Load, when air pressure and sump pressure are above 0.5 Mpa (72.5 PSI), if Delta across separator is above the set value, Will Alarm.
Oil Pressure Diff Trip (Mpa/PSI)	00.20/29.00	On Load, when air pressure and sump pressure are above 0.5 Mpa (72.5 PSI), if Delta across separator is above the set value, Will Trip.
Line Pressure Delta (Mpa/PSI)	00.05/7.25	Line pressure resistance.
Serial Number	1234567	Unit Serial Number.
Production Date	01.01.2017	Date of Build.
System P Low Stop (Mpa/PSI)	00.30/43.50	Monitors low compressor internal pressure, will alarm and trip after protection delay.

The following alarms will occur from this factory menu if set parameters are exceeded:

MESSAGE	MENU	CAUSE
MOTOR / FANCURR OVLD	Factory	Overload detected in Main of Fan Motor.
MOTOR CUR OPEN PHASE	Factory	Loss of Power Supply, Motor Winding, Contactor Failure.
MOTOR CURR UNBAL	Factory	Current imbalance of Main Motor.
HIGH VOLTAGE	Factory	3 Phase Voltage exceeding setting.
LOW VOLTAGE	Factory	3 Phase Voltage too low.
DISC T HIGH	Factory	Air end Temperature Reached.
FRONT BEARING STOP T	Factory	Air end Drive Bearing Temperature Excessive.
REAR BEARING STOP T	Factory	Air end Discharge Bearing Temperature Excessive.
HIGH P	Factory	Compressor Running Overpressure.
LOW TEMP PRO	Factory	Ambient too cold or Sensor Fault.
OIL PRES DIFF STOP	Factory	Oil Filter Blockage.
SYS P LOW STOP	Factory	Compressor Running too Low Internal Pressure.
PHASE WRONG 1	Factory	Incorrect Rotation Detected.
PHASE WRONG 2	Factory	Loss of Phase.
SENSOR FAULT	Factory	Temperature Sensor Disconnected or Faulty.

5.3.4 Calibration menu

Press MENU, Press CALIBRATION PARA, enter the password, press Enter and Confirm.

MENU	DEFAULT VALUE	FUNCTION
MOTOR A COEF:	1.000	Input the coefficient to calibrate current controller display Current = sample current * coefficient. Coefficient range: 0.800-2.000
MOTOR B COEF:	1.000	
MOTOR C COEF:	1.000	
FAN A COEF:	1.000	
FAN B COEF:	1.000	
FAN C COEF:	1.000	
T1 COEF:	1.000	Input the coefficient to calibrate discharge temperature. Controller display temperature = sample temp*coefficient Coefficient range: 0.800-2.000
T 2 COEF:	1.000	Note: this parameter is reserved in mam6090
T 3 COEF:	1.000	Note: this parameter is reserved in mam6090
T 4 COEF:	1.000	Note: this parameter is reserved in mam6090
T 5 COEF:	1.000	Note: this parameter is reserved in mam6090
T 6 COEF:	1.000	Note: this parameter is reserved in mam6090
P 1 COEF:	1.000	Input the coefficient to calibrate air pressure. Controller display pressure = sample pressure*coefficient Coefficient range: 0.800-2.000
P 2 COEF:	1.000	Note: this parameter is reserved in mam6090
P COEF:	1.000	Input the coefficient to calibrate air pressure. Controller display pressure = sample pressure*coefficient. Coefficient range: 0.800-2.000
MOTOR CURRENT CYCLE:	0004	Control the current update speed
VOLT CYCLE:	0004	Control the voltage update speed
T 1 ZERO:	0002	Calibrate controller temperature zero. Calibrate temperature to -20°C when controller pressure sensor terminal connects the resistance in accordance with -20°C. For the calibration of temperature, it is required to calibrate T zero first and then calibrate coefficient
T 2 ZERO:	0002	Note: This parameter is reserved in MAM6090
T 3 ZERO:	0002	Note: This parameter is reserved in MAM6090
T 4 ZERO:	0002	Note: This parameter is reserved in MAM6090
T 5 ZERO:	0002	Note: This parameter is reserved in MAM6090
T 6 ZERO:	0002	Note: This parameter is reserved in MAM6090
P 1 ZERO:	0002	When AIR P is below this set value, the pressure is displayed as 0.00. It is used to avoid air pressure transmitter from increasing
P 2 ZERO:	0002	When P 2 is below this set value, the pressure is displayed as 0.00. It is used to avoid pressure zero from increasing

P1 SENSOR RANGE:	01.60MPA	Set the range of pressure sensor that is connected to No.13 terminal of the controller
P2 SENSOR RANGE:	01.60MPA	Set the range of pressure sensor that is connected to No.12 terminal of the controller
PHASE PROT(V):	000.9	If the Three phase voltage is detected lower than the data set here, controller will report PHASE WRONG If PHASE PROT = 0, PHASE PROT is not activated
OPEN PHASE PROT(V):	000.0	If the open phase voltage is detected lower than the data set here, controller will report PHASE WRONG If OPEN PHASE protection = 0 second, OPEN PHASE protection is not activated Note: This parameter is reserved in MAM 6090
MOTOR CURR RATIO:	020	Motor rated current / 5
FAN CURR RATIO:	001	Fan rated current / 2.5
STANDBY:		For manufacturer calibration

5.3.5 Sequencing parameters

Press MENU, Press BLOCK PARA, enter the User password, press Enter and Confirm.

MAM 6090 has the capacity to control 16 compressors via a daisy chain RS485 series link utilizing RS485-1 terminals A1, B1 and GND1.

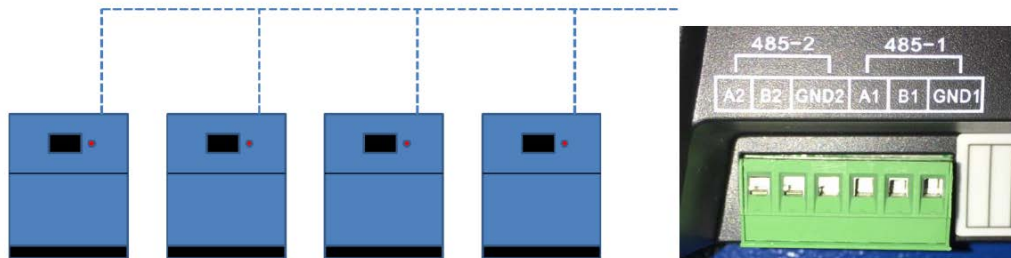

MENU	DEFAULT VALUE	FUNCTION
Block Number	0002	Number of Compressors to Sequence.
Block Load Pressure (Mpa/PSI)	00.63 /91.00	In Sequence Mode One Compressor Will Start and Load when master air pressure is below this set data.
Block Unload Pressure (Mpa/PSI)	00.78 /113.00	In Sequence Mode One Compressor Will Stop or Unload when master air pressure is above this set data.
Block Delay (S)	0020	Delay to Start and Load More than One Compressor.
Turn Time (M)	0060	Time to Change Over Master and Slave Compressor.
Block Mode	PF – PF	All Fixed compressors

	VSD – PF VSD - VSD	Variable and fixed combination All VSD's
--	-----------------------	---

To Set Master Control Compressor:

- a) Go to User Menu,
- b) Set COMM MODE to BLOCK
- c) Set COM ADD to OOO1 for Master Unit
- d) After setting, turn off Controller and Reboot to save this setting.

To Set Slave Compressors:

- a) Go to User Menu
- b) Set COMMS MODE to BLOCK
- c) Set COM ADD to OOO2 - 16 for Slave Unit
- d) The Sequence BLOCK Icon will appear on the Controller Screen

To Start / Stop Sequence BLOCK MODE:

- a) To activate BLOCK MODE start Master compressor first.
- b) Start each of the Slave units in turn.
- c) Allow the Compressors to Start and Stop themselves according to the settings already programmed.
- d) Stopping the Master compressor manually will deactivate the BLOCK Control.

Network Connection:

The MAM 6090 Controller supports MODBUS RTU protocol.

It supports 03, 06, 16 MODBUS commands.

Communication baud rate 9600 BPS

1 Start bit

8 Data bits

1 Stop bit

Even Parity

5.3.6 Hardware parameters

Hardware parameters are used to set the function of terminals 17-24, 31, 32 and 33.

MENU	PRESET DATA	FUNCTION
24 Terminal	Emergency	NO FUNCTION/EMERGENCY/REMOTE ON/REMOTE

23 Terminal		OFF/REMOTE INCHING/KEEP REMOTE / LACK WATER (N.C.)/REMOTE LOAD/REMOTE START
22 Terminal	Lack Water	ENABLE/REMOTE LOAD/UNLD /TANK HIGH T (N.C.)/
21 Terminal	Oil Filter	COIL HIGH T (N.C.)/ BEARING HIGH T (N.C.)/ ELEC
20 Terminal	O/A Separator	FAULT (N.C.)/MOTOR OVLD (N.C.)/FAN OVLD
19 Terminal	Air Filter	(N.C.)/OIL BLOCK (N.C.)/ OIL BLOCK (N.O.)/ O/A
18 Terminal	Multifunctional	BLOCK (N.C.)/O/A BLOCK (N.O.)/AIR FILTER
		BLOCK (N.C.)/AIR FILTER BLOCK (N.O.)/ AIR FAULT
		(N.C.)/DRYER FAULT (N.C.)/ MOTOR INV FAULT
		(N.O.)/ MOTOR INV FAULT (N.C.)/ FAN INV FAULT
		(N.O.)/ FAN INV FAULT (N.C.).
		Note: User can set different digital input functions.
33 Relay Function	Run	NO FUNCTION/ALARM/RUN/FAULT/READY/REMOTE/
32 Relay Function	Fault	START MOTOR INVERTER/START FAN INVERTER
31 Relay Function	Alarm	Note: User can set different relay output functions.

5.3.7 Maintenance parameters

Press MENU, press MAIN PARA, enter the password, press Enter and Confirm.

MENU	DEFAULT VALUE	FUNCTION
Oil Filter Run Time (H)	0000	Service of Oil Filter Real Time. When replacing oil filter it has to be manually reset.
Air/Oil Separator Run Time (H)	0000	Service of Separator Element Real Time. When replacing separator it has to be manually reset.
Air Filter Run Time (H)	0000	Service of Air Filter Real Time. When replacing air filter it has to be manually reset.
Lubricant Run Time (H)	0000	Service of Lubricant Real Time. When replacing oil it has to be manually reset.
Grease Run Time (H)	0000	Service of Grease Real Time. When greasing it has to be manually reset.
Oil Filter Max Run Time (H)	2000	Alarm Prompt Hours. Set to 0000 and function is disabled
Air/Oil Separator Max Run Time (H)	2000	Alarm Prompt Hours. Set to 0000 and function is disabled
Air Filter Max Run Time (H)	2000	Alarm Prompt Hours. Set to 0000 and function is disabled
Lubricant Max Run Time (H)	2000	Alarm Prompt Hours. Set to 0000 and function is disabled
Grease Max Run Time (H)	2000	Alarm Prompt Hours. Set to 0000 and function is disabled

The following alarms will occur from this maintenance menu if set parameters are exceeded:

ALARM	MENU	MESSAGE
Air filter alarm	Digital # 19	AIR BLOCK
	Maintenance	AIR TIME END
Oil filter alarm	Digital # 21	OIL BLOCK
	Maintenance	OIL TIME END
Separator alarm	Digital # 20	O/A BLOCK
	Maintenance	O/A TIME END
Lubricant alarm	Maintenance	LUBE TIME END
Grease alarm	Maintenance	GREASE TIME END

5.3.8 Inverter set

Press MENU, press INVERTER PARA, enter the password, press Enter and Confirm.

The following chart is an example for Schneider inverter ATV61, ATV71.

MENU	SET DATA	FUNCTION
Inverter Name	0ATV61	Set inverter name, communicate any inverter supporting Modbus.
Run (W) Add1	2135	Corresponding address 1 of inverter start command.
Run Value	0001	This data is inverter start data (please refer to communication chapter in inverter manual for different inverter).
Run (W) Add2	2135	Corresponding address 2 of inverter start command.
Run Value	0001	This data is inverter start data (please refer to communication chapter in inverter manual for different inverter).
Stop (W) Add	2135	Corresponding address of inverter stop command.
Run Value	0001	This data is inverter start data (please refer to communication chapter in inverter manual for different inverter).
Reset (W) Add	2135	Corresponding address of inverter reset command
Run Value	0001	This data is inverter start data (please refer to communication chapter in inverter manual for different inverter).
Freq (W) Add	2136	Corresponding register address of inverter running frequency source.

Freq (R)	REC*0001÷0001	The REC value is frequency value with one decimal. Use formula to transfer to corresponding value based on different inverter and send it to inverter. Example 50HZ running frequency REC value500 For inverter with write frequency of 2 decimals, formula REC**0001÷0010 For inverter with write frequency of 1 decimal, formula REC**0001÷0001 For the inverter whose max output frequency is in corresponding with 10000, the formula REC*0020÷0001
Tate (R) Add	2135	Read inverter running status address
Run S	R AND 0001=0001	Check if inverter has run the formula (please refer to communication chapter in inverter manual).
Com Form	8N1-N	Set the data format of controller and inverter Communication. This set should be consistent with inverter communication format. 8N1-N 1start bit,8 data bits,1 stop bit, no parity bit 8N1-E 1start bit,8 data bits,1 stop bit, even parity bit 8N1-O 1start bit,8 data bits,1 stop bit, odd parity bit 8N2-N 1start bit,8 data bits,2 stop bit, no parity bit Note Communicate with inverter, the baud rate is fixed 9600.
Freq (R) Add	0C82	Read inverter frequency address (refer to inverter manual).
Freq (R)	REC*0001÷0001	Calculate inverter frequency formula. Controller will transfer the frequency to one decimal.
Volt(R) Add	0C88	Read inverter voltage address.
Volt (R)	REC*0001÷0001	Calculate inverter voltage formula. Controller will transfer the voltage to one decimal.
Curr (R) Add	0C84	Read inverter current address.
Curr (R)	REC*0001÷0001	Calculate inverter current formula. Controller will transfer the current to one decimal.
Power (R) Add	0C8B	Read inverter power address.
Power (R)	REC*S*0001÷01 00	Calculate inverter power formula. Controller will transfer the power to one decimal.
Err Add	6500	Read inverter error address.
Err S=R	AND 0000≠0000	Inverter reports error formula or not.
Emergency Add	2135	Corresponding add of inverter emergency stop command.
Run Value	0001	This data is inverter start data (please refer to communication chapter in inverter manual for different inverters.)

5.3.9 Touch screen calibration

Touch calibration is used to adjust touch accuracy.

Press MENU, press TOUCH CALIB, enter the password, press Enter and Confirm.

After entering touch calibration menu, use fingertip to click A , B ,C ,D in sequence. Press “S” button to restart and save the modification.

5.3.10 Scheduled pressure

SCH PRES menu will run the compressor within the Pressure Band within the boundaries of the P START and P STOP times programmed.

Outside the time boundary the compressor will go into Standby Mode and will not start even if the pressure drops below minimum setting.

Press MENU, press SCH PRES, enter the password, press Enter and Confirm.

MENU	DEFAULT VALUE	FUNCTION
Load P (Mpa)	00.65	Will Start and Load if Between Start and Stop Schedule Time Set if air pressure is below this setting.
Unload P (Mpa/PSI)	00.80/116.00	Will Unload if Between Start and Stop Schedule Time Set if air pressure is above this setting.
Scheduled VSD P (Mpa/PSI)	00.70/101.50	VSD Optimum Pressure Between Start and Stop Schedule Time Set (This data is only available in MOTOR VSD or MOTOR/FAN VSD mode).
P Start Time	00.00	Set Time to Activate Schedule. 00.00 Means not Activated.
P Stop Time	00.00	Set Time to Deactivate Schedule. 00.00 Means not Activated.

5.3.11 Schedule ON-OFF

Press MENU, press SCH WORK, enter the password, press Enter and Confirm.

SCH WORK is Time specific and can be programmed for up to 4 scheduled on/off periods per day. When set to 0000, the function is disabled.

5.3.12 History record

Select FAULT REC. Stores 100 faults in history file. Can be Reset in Factory Menu.

5.3.13 Motor VSD

Press MENU, press MOTOR VSD, enter the password, press Enter and Confirm.

MENU	PRESET VALUE	FUNCTION
VSD P (Mpa/PSI)	00.70/101.50	Optimum Pressure Setting for VSD mode.
Motor Up Speed	1000	Motor Acceleration Speed.
Motor Down Speed	1000	Motor Deceleration Speed.
Motor Rated Power (kW)	022.0	Input Rated Power of Motor from nameplate to calculate actual power in VSD mode.
Motor Rated Speed (RPM)	1500	Input Motor Speed at 50 HZ from nameplate to calculate actual speed in VSD mode.
Motor Int Initial	0080	Integral calculation is based in this data.
Motor Int Scale	00.05	Integral gain.
Motor PF	0.800	Input Motor PF from nameplate to calculate motor power.
Motor Prop Gain	0025	Track the speed of PID TARGET P.
Motor Int Gain	0030	Track the speed of PID TARGET P and STEADY STATE ERROR.
Motor Diff Gain	0000	Not used leave as default 0000.
Motor Max Frequency	060.OHZ	Set Maximum Permitted Frequency at Full Load.
Motor Min Frequency	030.OHZ	Set Minimum Permitted Frequency at Low Speed.
Motor Unload Frequency	025.OHZ	Permitted Frequency in Unload Mode.
Motor Inverter Add	001	Set MOTOR VSD ADD same as VSD CONN ADD.
Motor PID Cycle (S)	000.8S	Set to Adjust Motor Speed.
Motor Inverter Model	ATV61	Set Model of Inverter (Must Support MODBUS RTU).
Motor Stop Mode	Slow/Free	1. Inverter START MODE to COMM ON / OFF SLOW; When Controller receives a stop command INLET VALVE closes and INVERTER send signal to SLOW STOP. FREE; When Controller receives a stop command INLET VALVE closes and Controller sends write frequency through RS485. Controller frequency will decrease and send STOP command to inverter. 2. Inverter START MODE to TERMINAL ON /OFF SLOW; When Controller receives a stop command INLET VALVE closes and MOTOR INVERTER RUN terminal will open. The compressor will stop according to STOP DELAY set. FREE; When Controller receives a stop command INLET VALVE closes and MOTOR INVERTER RUN terminal will keep closed to control Inverter Frequency until STOP DELAY is completed.
Inverter Start Mode	Comm/terminal	COMM ON / OFF. Start or Stop Inverter thru RS485 Terminal ON / OFF. Start or Stop Inverter through

		Digital Signal. 1. Controller should be set in INVERTER START MODE. 2. When Controller is set to PF/ VF terminal 12 functions as an Inverter control terminal so only COM ON/ OFF is available to control Inverter.
Inverter Starts Permitted	0006	Maximum start commands to Inverter with no response.
Inverter Stops Permitted	0006	Maximum stop commands to Inverter with no response.
VSD Power Consumption Kwh	00000.0	Set the accumulative kW/hr of VSD.
Motor Inverter Delay (S)	1.0	Delay time Start Button command to Inverter.
Constant Power Pressure 1 (Mpa/PSI)	0.60/87.00	In CONSTANT POWER running mode, when pressure is above the data set here, setting will determine maximum output frequency CONSTANT POWER FREQUENCY 1.
Constant Power Pressure 2 (Mpa/PSI)	0.70/101.50	In CONSTANT POWER running mode, when pressure is above the data set here, setting will determine maximum output frequency CONSTANT POWER FREQUENCY 2.
Constant Power Pressure 3 (Mpa/PSI)	0.80/116.00	In CONSTANT POWER running mode, when pressure is above the data set here, setting will determine maximum output frequency CONSTANT POWER FREQUENCY 3.
Constant Power Pressure 4 (Mpa/PSI)	0.90/130.5	In CONSTANT POWER running mode, when pressure is above the data set here, setting will determine maximum output frequency CONSTANT POWER FREQUENCY 4.
Constant Power Pressure 5 (Mpa/PSI)	1.00/145.00	In CONSTANT POWER running mode, when pressure is above the data set here, setting will determine maximum output frequency CONSTANT POWER FREQUENCY 5.
Constant Power Pressure 6 (Mpa/PSI)	1.10/159.50	In CONSTANT POWER running mode, when pressure is above the data set here, setting will determine maximum output frequency CONSTANT POWER FREQUENCY 6.
Constant Power Pressure 7 (Mpa/PSI)	1.20/174.00	In CONSTANT POWER running mode, when pressure is above the data set here, setting will determine maximum output frequency CONSTANT POWER FREQUENCY 7.
Constant Power Frequency 1 (Hz)	180.0	Note 1 : In Constant Power running Constant Power Pressure 1 ≤ Constant Power Pressure 2 ≤ Constant Power Pressure 3 ≤ Constant Power Pressure 4 ≤ Constant Power Pressure 5 ≤ Constant Power Pressure 6 ≤ Constant Power
Constant Power Frequency 2 (Hz)	160.0	

Constant Power Frequency 3 (Hz)	140.0	Pressure 7. Note 2: Constant Power Frequency 1 ≥ Constant Power Frequency 2 ≥ Constant Power Frequency 3 ≥ Constant Power Frequency 4 ≥ Constant Power Frequency 5 ≥ Constant Power Frequency 6 ≥ Constant Power Frequency 7. Note 3: If M>N, When Constant Power Pressure N is set to 00.00, Constant Power Pressure M and Constant Power Frequency M are invalid. Note 4: When Constant Power function is not required set Constant Power Pressure to 00.00.
Constant Power Frequency 4 (Hz)	120.0	
Constant Power Frequency 5 (Hz)	100.0	
Constant Power Frequency 6 (Hz)	80.0	
Constant Power Frequency 7 (Hz)	60.0	
Int Gain 2		Track the speed of PID TARGET P and Steady State Error, the bigger the data ,the faster the track and smaller the steady-state errors; the smaller the data ,the slower the track and bigger the steady-state errors.
Int Gain Scale (Mpa)		Set the function scale of Int Gain 2.

5.3.14 Fan VSD

Press MENU, press FAN VSD, enter the password, press Enter and Confirm.

MENU	PRESET VALUE	FUNCTION
Fan Vsd T (°C/°F)	0078/0172	In VSD mode, set DISC T to keep running stable. When DISC T is fluctuating around this data, controller will adjust operating frequency of fan inverter to control DISC T close to this data.
Max Vsd T (°C/°F)	0085/0185	When DISC T is above or equal to this data, control fan inverter output frequency is adjusted to FAN MAX FREQ .
Fan Up Speed	1000	Restrict PID calculations in case the frequency is increasing too fast which cause fan speeding up too fast.
Fan Dn Speed	1000	Restrict PID calculations in case the frequency is decreasing too fast which cause fan slowing down too fast.
Fan Rated Power (KW)	001.5	Set FAN RATED POWER to calculate the actual fan power in FAN VSD mode.
Fan Rated Speed (RPM)	1500	Set the corresponding fan speed in 50HZ to calculate actual fan speed in FAN VSD mode.

Vsd Fan Start T (°C/°F)	0070/0158	VSD fan will start if DISC T is above this set data.
Vsd Fan Stop T (°C/°F)	0065/0149	VSD fan will stop if DISC T is below this set data.
Fan Int Initial (°C/°F)	0020/0068	When detected DISC T<(PID TARGET T -INTEGRAL SCALE) or Detected DISC T>(PID TARGET T +INTEGRAL SCALE) Integral calculation is based on this data.
Fan Int Scale (°C/°F)	0005/0041	(PID TARGET T - INTEGRAL SCALE)< detected DISC T < (PID TARGET T + INTEGRAL SCALE, INTEGRAL GAIN works. Beyond this range, INT INITIAL works.
Fan Prop Gain	0100	Track speed of PID TARGET T , the bigger the data, the faster the track and the less stable the data; the smaller the data the slower the track and the slower the adjustment.
Fan Int Gain	0020	Track the speed of PID TARGET T and steady state error, the bigger the data ,the faster the track and smaller the steady-state errors; the smaller the data ,the slower the track and bigger the steady-state errors.
Fan Diff Gain	0000	Normally set as "0000", this function is not activated.
Fan Max Freq (Hz)	060.0	In the process of adjustment, The maximum operating frequency when temperature is over the VSD work temperature.
Fan Min Freq(Hz)	010.0	In the process of adjustment, The minimum operating frequency when temperature is below the VSD work temperature.
Vsd Fan Power Coef	0.900	Coefficient to calculate vsd fan power.
Fan Inverter Add	2	Set the FAN VSD ADD and keep it consistent with VSD COM ADD.
Fan Pid Cycle (S)	001.5S	Set the PID calculation interval time to adjust fan speed.
Fan Inverter Model	ATV31	Choose inverter protocol.
Fan Inverter Start Mode	COM/TERMINAL	Set fan inverter start mode.
Vsd Fan Elec (Kw.H)	000000.00	VSD fan power consumption.

5.3.15 Date and Time

Select DATE. Set real time and date.

5.4. Technical Parameters

1. Ambient: -20 ~ 60°C (-4 ~ 140°F).
2. Digital Inputs: 8.

3. Digital Output relays: 10 (250VAC ~ 5A capacity).
4. Analog Inputs: 3 x PT100.
5. Transducer Inputs: 2 x 4-20ma.
6. CTs Input: 2 x 3 phase groups.
7. Voltage Options: 460 / 400 / 220 VAC.
8. Controller Power Supply: 16-28VAC, 20VA.
9. RTD Range: -50 ~ 350 °C (-58 ~ 284°F).

TEMP. °C	TEMP. °F	Ohms
-20	-4.0	92.16
-10	14.0	96.09
0	32.0	100
10	50.0	104
20	68.0	107.79
30	86.0	111.67
40	104.0	115.54
50	122.0	119.4
60	140.0	123.24
70	158.0	127.07
80	176.0	130.89
90	194.0	134.7
100	212.0	138.5
110	230.0	142.29
120	248.0	146.06

10. Running Time: 0 ~ 999999 hours
11. Current: 0 ~ 999.9 A
12. Pressure Transducer: 0 ~ 16 bar (0~232PSI), 4-20mA, 28VDC.
13. RS485 port 1: For Sequence or Computer communication.
14. RS 485 port 2: For Inverter control.
15. Phase reversal protection response time ≤ 1 s.
16. High temperature response time ≤ 2 s.
17. Overload protection response time:

I actual / I set	≥ 1.2	≥ 1.3	≥ 1.5	≥ 1.6	≥ 2.0	≥ 3.0
Response time (s)	60	48	24	8	5	1

5.5. Alarms

FAULT	PROBABLE REASON	REMEDY
High discharge temperature	Bad vent condition, Oil shortage etc.	Check the vent condition, lubricant level, etc.
Temperature Sensor Failure	Cable broken or PT100 failure	Check the wiring and PT100.
High Pressure	Pressure too high or pressure sensor failure	Check the pressure and the pressure sensor.
Pressure Sensor Failure	Cable broken, Sensor failure or the cables connect reversely	Check the wiring and pressure transmitter.
Open Phase	Power open phase or contactor failure	Check the power and contactors.
Overload	Voltage too low, tubes block, bearing wear off or other mechanical failure or wrong set data etc.	Check the set data, voltage, bearings, tubes and other mechanical system.
Unbalance	Current unbalance, contactor failure or the internal open loop of the motor	Check the power, contactor and the motor.
Wrong Phase Sequence	Phase sequence reversal or open phase	Check the wiring.
Motor overload during start	Master start time set to less than the star delta delay time	Reset the master start time longer than star delay + 2 seconds.
Main Contactor shakes frequently	The emergency stop button is loose or controller is reset by interference	Check if the coil of contactor connects with RC snubber or not.
Inverter Communication Fault	Wrong set of relatively parameter of controller and Inverter; Communication cable loose	Check the set data; Check the cable.

Servicing

KRSD compressors require the minimum amount of inspection and maintenance. The controller and indicator alerts the operator to perform required maintenance or repair unit problems.

6.1 FLUID CHANGE

KRSD series compressors utilize a pressurized fluid drain. Use the following procedure to drain and replace the compressor fluid.

- i. Press the emergency stop button and remove the right side cabinet panel (if applicable).
- ii. Check the pressure gauge reading on reservoir and wait until reservoir pressure drops to approximately 0.5Bar (7psig).
- iii. Close the 1/4 turn valve on the blow-down valve.
- iv. Remove the drain plug and attach the 1/4 NPT barb fitting and drain tube (supplied with the unit) to the drain on the oil/air separator tank.
- v. Slowly open the 1/4 turn valve on the drain of oil/air separator tank. The pressure remaining in the tank will force the fluid out. When air begins to escape from the tank, close the valve.
- vi. After closing the valve, remove the tubing and barb fitting and reinstall the drain plug.
- vii. Remove the plug from the fluid fill port and refill the reservoir with the appropriate amount of KTL8000 fluid.
- viii. Before starting the compressor open the 1/4 turn valve on the blow-down valve to ensure the blow-down valve functions correctly.



NOTICE

The 1/4 turn valve on the blow-down valve **MUST** be open for the unit to blow down during regular unit operation.

6.2 AIR FILTER

The standard Kaishan air filter is a single stage, dry type element. Air filter maintenance should be performed when the maintenance gauge shows red with the compressor running full load, or every 4,000 hours, or once a year, whichever comes first. Daily cleaning of the filter element is common in dirty conditions. If dirty conditions exist, it is advisable to relocate the intake air to an outside source. Each time the filter is serviced, inspect the filtered air side of the air cleaner canister and the suction manifold for dirt. If dirt is found, determine the cause and correct. Always make sure all gaskets, threaded connections, flange connections, and hose connections between the air filter and air compressor are

airtight. Dirty filters result in reduced airflow and can distort the element and allow dirt to bypass the filter element.



NOTICE

Intake filtration equipment supplied from the factory may not be adequate for extremely dirty applications or some forms of dust or vapors. It is the customer's responsibility to provide adequate filtration for those conditions. Warranty will be voided if inadequate filtration causes a failure.

6.3 FLUID FILTER

The fluid filter is a spin on, full flow unit. Replacement of the filter requires spinning off the cartridge and replacing it with a new one. The initial filter change should occur after the first 500 hours of operation. During normal service, the filter cartridge should be replaced under the following conditions, whichever occurs first:

- ◆ As indicated by the fluid filter maintenance indicator when the fluid is at normal operating temperature
- ◆ Every 2,000 hours
- ◆ Every fluid change



NOTICE

The fluid filter maintenance indicator may read high upon start up on cool mornings due to sluggish fluid creating higher than normal differential pressures. Monitor indicator after the fluid warms up.

6.4 AIR/OIL SEPARATOR

The air/oil separator is a coalescent filter element. Replacement of standard type separator requires unbolting and lifting the separator cover and replacing it with a new one. The air/oil separator should be replaced as indicated in the maintenance schedule or as follows:

- ◆ If excessive fluid carryover is observed.
- ◆ 4,000 hours MAX (for spin on type), 8,000 hours MAX for standard type, or-as indicated by differential pressure indicator.
- ◆ As indicated by the gauge (if equipped).

6.5 FLUID SAMPLING PROCEDURE

The following is a sampling procedure for oil sump without fixed sampling hardware installed. Check the pressure gauge reading on reservoir and wait until there is no pressure in reservoir. The oil sample is collected by gravity drain into the sample bottle.

- i. Take sample at normal operating conditions or immediately after shutting unit down. That will ensure a homogeneous sample of oil.
- ii. Wipe excess contamination from sample area.
- iii. Remove drain plug. Drain any free water that may accumulate at tank bottom *before* filling sample bottle. If system has drain pipe, flush about 5 times the volume of the dead leg before taking sample.
- iv. Avoid overfilling the sample bottle. Fill sample bottle up to above 80% but below the threads of the bottle. Seal the bottle tightly, wipe clean.

Pre-label or label sample bottle immediately after filling to avoid mix-ups. Make sure bottles are labelled with full sample details.

6.5 MAINTENANCE SCHEDULE

This Schedule is intended to be used as a guideline only. Depending on the specific operating conditions of your KRSD compressor, maintenance requirements may vary. The instructions in this section will give more details about determining when specific service should be performed.

First 500 hours	Change fluid filter and check fluid level
Every 500 hours	Drain water from air/oil separator tank. Check fluid level Clean air filter Clean after-cooler fins. Check for loose fluid and air tubing, electrical wiring connection.
Every 1000 hours	Clean air filter or replace with new element. Clean after-cooler fins.
Every 2000 hours	Check safety valve Replace fluid filter. Perform fluid sampling.

Every 4000 hours	Replace air filter. Replace air/oil separator (spin on type)
Every 8000 hours	Check equipment power supply and earth-grounding. Replace air/oil separator (standard type). Replace fluid.

Troubleshooting Guide

Information below is a troubleshooting guideline; it describes symptoms and possible cause. Do not assume that these are the only faulty condition that may occur.

Table 7-1: TROUBLE SHOOTING GUIDE		
Symptom	Possible Cause	Solution
Fail to Start	Power failure	Check power supply to the unit
	Low incoming voltage	Check voltage and power source, or contact local power company.
	Fuse blown	Replace Fuse
	Faulty start switch	Check the switch for malfunction or loose connection.
	Emergency button	Reset emergency button
	Motor starter overload tripped	Check motor starter wiring before removing motor. Remove motor and have tested at motor manufacturer repair center.
	Loose wire connections	Check all wiring terminals for contact and tightness
	Air-end failure	Contact a local authorized distributor.
Compressor shuts down during loaded condition	High ambient temperature	Make fresh air intake openings or install ducts to discharge the hot air.
	Low incoming voltage	Check voltage and power source, or contact local power company.
	High operating pressure	Reset, check line pressure and ensure it does not exceed the compressor's maximum operating pressure.
	Low fluid level	Top-up fluid
	PLC controller indicate separator requires maintenance	Replace separator element.
Line pressure rises above unload pressure set-point	Control system air leakage causing loss of pressure	Check for leak
	Plugged air filter	Replace air filter element
	Air Intake valve stuck open	Remove the intake hose and check the inlet valve for proper operation
	Defective blow-down valve	Check the receiver tank to ensure that it is exhausting air to the atmosphere when the solenoid opens - repair or replace if necessary.

Table 7-1: TROUBLE SHOOTING GUIDE (Continued)

Symptom	Possible Cause	Solution
Compressor does not reload when service line pressure drops to reset	Faulty solenoid	Repair or replace as necessary
	Loose wiring connection	Check and tighten wiring terminals
	Faulty proportional valve	Orifice plugged. Clean or replace as necessary
	Jammed air inlet valve assembly	Check and repair air inlet valve
	Faulty air pressure sensor	Repair or replace as necessary
High air discharge temperature	Low Fluid Level	Check oil level
	Incorrect fluid brand	Check oil code number, replace as necessary
	High ambient temperature	Check air exhaust, reduce room temperature.
	Plugged oil filter	Change oil filter
	Plugged internal aftercooler	Chemical cleaning for after-cooler
	Dusty after-cooler fins	Chemical wash for after-cooler fins
	Fan motor setting	Adjust
	Temperature sensor failure	Check and replace as necessary
	Loose wire	Check and tighten
Low air capacity delivery	Plugged air filter	Clean air filter or replace with new element
	Air Intake valve failure	Remove the intake hose and check the inlet valve for proper operation
	Separator failure	Replace separator element
	Faulty indirect proportional valve	Adjust or replace as necessary
	Faulty solenoid	Repair or replace as necessary
	Faulty safety valve	Repair or replace as necessary
Excessive oil carry over in discharge compressed air.	High oil level	Check oil level
	Plugged oil orifice valve	Clean or replace as necessary
	Low discharge pressure	Adjust
	Air/oil separator element failure	Clean or replace as necessary
	Minimum pressure valve malfunction	Check for leaking, replace as necessary
Loading function Failure	Solenoid valve failure	Check and replace as necessary
	Pipe leak	Check and replace as necessary
	Proportional valve failure	Check and replace as necessary
	Air Intake valve stuck open	Remove the intake hose and check the inlet valve for proper operation
	Minimum pressure valve failure	Check for leaking, replace as necessary

Table 7-1: TROUBLE SHOOTING GUIDE (Continued)		
Symptom	Possible Cause	Solution
Unloading failure at working pressure, causing safety valve to release pressure	Pressure loading setting	Adjust as necessary
	Solenoid valve failure	Check and replace as necessary
	Plugged air/oil separator	Check and replace as necessary
	Air Intake valve stuck open	Remove the intake hose and check the inlet valve for proper operation
	Safety valve failure	Repair or replace as necessary
	PLC controller failure	Check and replace as necessary
Compressor air discharge pressure below normal operating settings	Plugged air filter	Clean or replace as necessary
	Air Intake valve stuck closed	Remove the intake hose and check the inlet valve for proper operation
	Plugged air/oil separator	Check or replace as necessary
	Indirect proportional valve setting	Adjust or replace as necessary
	Solenoid valve failure	Check and replace as necessary
	Safety valve failure	Check and replace as necessary
Short period of load/unload	Pipe leak	Check and replace as necessary
	Pressure setting	Change setting above 1Bar
	Receiver tank too small	Check or increase volume of receiver tank
	Air flow into the main network restricted	Increase pipe size. Checks filter cartridge failure.
Oil vapor leak from air filter when compressor stops	Air inlet valve failure	Check and replace as necessary
	Minimum pressure valve failure	Check for leaks and replace as necessary
	Pressure relief valve failure	Check and replace as necessary
Excessive Fluid Consumption	Different oil is being used.	Use KRSD genuine fluid.
	Separator element damaged	Check and replace as necessary.
	Oil level too high	Drain off oil until the correct level.
	Fluid foaming	Drain off oil and change
	Oil return line or orifice clogged	Clean and replace as necessary.

Standard Terms and Conditions

These terms and conditions govern the sale of Products (“Rotary Screw Air Compressors and parts”) and provisions of services by Kaishan Compressor USA, Ltd. (Seller) and its authorized representative or buyer. These terms and conditions (“Agreement”) take precedence over Buyer’s supplemental or conflicting terms and conditions to which notice of objection is hereby given. Neither Seller’s commencement of performance or delivery shall be deemed or construed as acceptance of Buyer’s supplemental or conflicting terms and conditions. Kaishan Compressor’s failure to object to conflicting or additional terms will not change or add to the terms of this agreement. Buyer’s acceptance of the Products and/or Services from Seller shall be deemed to constitute acceptance of the terms and conditions contained herein.

Orders: All orders placed by Buyer are subject to acceptance by Seller. Orders may not be canceled or rescheduled without Seller’s written consent. All orders must identify the products, unit quantities, part numbers, applicable prices and requested delivery dates of the Products being purchased. Seller may at its sole discretion allocate Product among its Buyer. Seller may designate certain Products and Services as non-cancelable, non-returnable and the sale of such Products shall be subject to the special terms and conditions contained in Seller’s Customer Acknowledgment or Non-Returnable Product Form, which shall prevail and supersede any inconsistent terms and conditions contained herein or elsewhere.

Prices: The prices of the Products are those prices specified on the front of the invoice or contained within an agreed written contract. Price quotations shall automatically expire in thirty (30) days from the date issued, or as otherwise stated in the quotation.

Taxes: Unless otherwise agreed to in writing by Seller, all prices quoted are exclusive of transportation and insurance costs, duties, and all taxes including federal, state and local sales, excise and value added, goods and services taxes, and any other taxes. Buyer agrees to indemnify and hold Seller harmless for any liability for tax in connection with the sale, as well as the collection or withholding thereof, including penalties and interest thereon. When applicable, transportation and taxes shall appear as separate items on Seller’s invoice.

Payment: Payment may be made by check, money order, credit card, or wire transfer (all fees are borne by the Buyer). Where Seller has extended credit to Buyer, terms of payment shall be net thirty (30) days from date of invoice, without offset or deduction. On any past due invoice, Seller may impose a monthly interest rate. If Buyer fails to make the required payments the Seller will impose the interest rate each month. If Buyer fails to make each payment when it is due, Seller reserves the right to withdraw credit and thereby suspend or cancel performance under any or all purchase orders or agreements in which Seller has extended credit to Buyer. In the event of default by Buyer, Seller shall be entitled to costs, fees, and expenses including but not limited to recovery of attorney fees, court costs and fees, and collections costs.

Delivery and Title: The locations of shipment delivery will be made according to the Seller and Buyer agreement. Title and risk of loss pass to the Buyer upon delivery of the Product to

the carrier. Seller's delivery dates are estimates only and Seller is not liable for delays in delivery or for failure to perform due to causes beyond the reasonable control of the Seller, nor shall the carrier be deemed an agent of the Seller. A delayed delivery of any part of an Order does not entitle Buyer to cancel other deliveries. Kaishan Compressor will comply with various federal, state and local laws and regulation concerning occupational health, safety and environment concerns. Buyer has full responsibility to comply with those laws and regulations during the installation and operation of the equipment.

Acceptance / Returns: Shipments will be deemed to have been accepted by Buyer upon delivery of the said shipments to Buyer unless rejected upon receipt. Buyer shall perform all inspections and tests. Buyer deems necessary as promptly as possible but in no event later than 7 days after receipt of Products, at which time Buyer will be deemed to have irrevocably accepted the Products. Any discrepancy in shipment quantity must be reported within 7 days after receipt of Products. Buyer may not return Products without a Return Material Authorization ("RMA") number. RMA's valid for 30 days from the date issued.

Standard Warranty: Buyer will honor Product warranties and indemnities authorized by the manufacturer, including any transferable. 90 days warranty is given for service parts from receipt date. Seller warrants to Buyer that Products purchased hereunder will conform to the applicable manufacturer's specifications for such products and that any value-added work performed by Seller on such Products will conform to applicable Buyer's specifications. If Seller breaches this warranty, Buyer's remedy is limited to (at Seller's election) (1) refund of Buyer's purchase price for such Product (without interest), (2) repair of such Products, or (3) replacement of such Products provided that such Products must be returned to Seller, along with acceptable evidence of purchase within 13 days from date of delivery, transportation charges prepaid. No warranty will apply if the Product has been subject to misuse, neglect, accident or modification.

Limitation of Liabilities: Buyer shall not be entitled to, and Seller shall not be liable for, loss of profit or revenue, promotional or manufacturing expenses, overheads expenses, business interruption cost, loss of data, removal or reinstallation costs, injury to reputation of buyer, punitive damages, loss of contractor orders or any indirect, special, incidental or consequential damages of any nature. Buyer's recovery from seller for any claim shall not exceed the purchase price paid for the affected products irrespective of the nature of the claim whether in contract, tort, warranty, or otherwise. Buyer will indemnify, defend and hold seller harmless from any claims based on (a) Seller's compliance with buyer's designs, specifications, or instructions, (b) Modification of any products by anyone other than Seller, or (c) use in combination with other products not supplied by seller.

Use of Products: Unless otherwise specified. Products sold by Seller are not designed, intended or authorized for use in life support, life sustaining, nuclear, or other applications in which the failure of such Products could reasonably be expected to result in personal injury, loss of life or catastrophic property damage. If buyer uses or sales the Products for use in any such applications: (1) Buyer acknowledges that such use or sale is at Buyer's sole risk; (2) Buyer agrees that Seller and the manufacturer of the Products are not liable, in whole or in part, for any claim or damage arising from such use; and (3) Buyer agrees to indemnify, defend and hold Seller and the manufacturer of the Products harmless from and against any and all claims, damages, losses, costs, expenses and liabilities arising out of or in connection with such use or sale.

Force Majeure: Seller is not liable for failure to fulfill its obligations for any accepted Order or for delays in delivery due to causes beyond Seller's reasonable control including, but not limited to, acts of God, natural or artificial disaster, riot, war, strike, delay by carrier, shortage of Product, acts or omissions of other parties, acts or omissions of civil or military authority, Government priorities, changes in law, material shortages, fire, strikes, floods, epidemics, quarantine restrictions, acts of terrorism, delays in transportation or inability to obtain labor, materials or products through its regular sources, which shall be considered as an event of force majeure excusing Seller from performance and barring remedies for non-performance. In an event of force majeure condition, the Seller's time for performance shall be extended for a period equal to the time lost as a consequence of the force majeure condition without subjecting Seller to any liability or penalty. Seller may, at its option, cancel the remaining performance, without any liability or penalty, by giving notice of such cancellation to the Buyer.

General: (a) Seller will comply with state law for any dispute from buyer. (b) Buyer may not assign this Agreement without the prior written consent of Seller. Seller or its affiliates may perform the obligations under this Agreement. This Agreement is binding on successor and assigns, (c) Products, including software or other intellectual property, are subject to any applicable rights of third parties, such as patents, copyrights and/or user licenses.

Contact Information

Kaishan Compressor, LLC.,

Add.: 7650-A Stanton St., Daphne, AL ,Post code: 36526

Office number: +1 251-202-0577

www.KaishanUSA.com