

		- REVISIONS -					
ZONE	REV	DESCRIPTION	CHG BY	CHK BY	APP BY	REL BY	DATE
-	A	CHANGED FILTER PACKAGES.	SDM	DEH	DEH	SDM	10/16/06
-	B	REMOVED UNNEEDED DETAIL A	DL	DEH	DEH	SDM	2/16/07
-	C	CHANGED ELECTRICAL PANEL & VALVES	CPC	DEH	DEH	SDM	03/11/10
B-4	D	ADDED SINGLE PROBE DUAL RTD/THERMOCOUPLE	SOM/BEC	KL	DEH	SOM/BEC	05/31/19

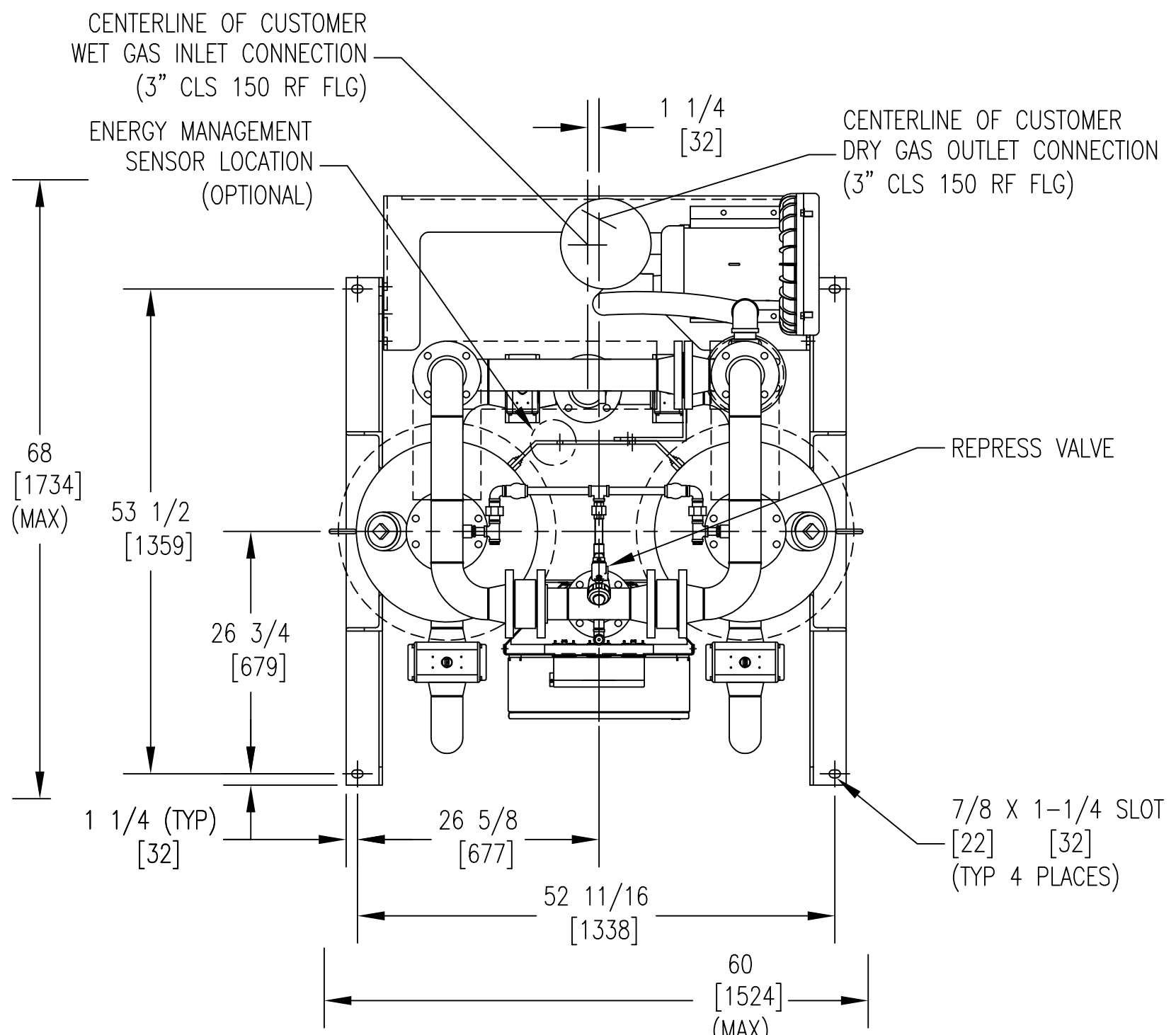

TOP VIEW

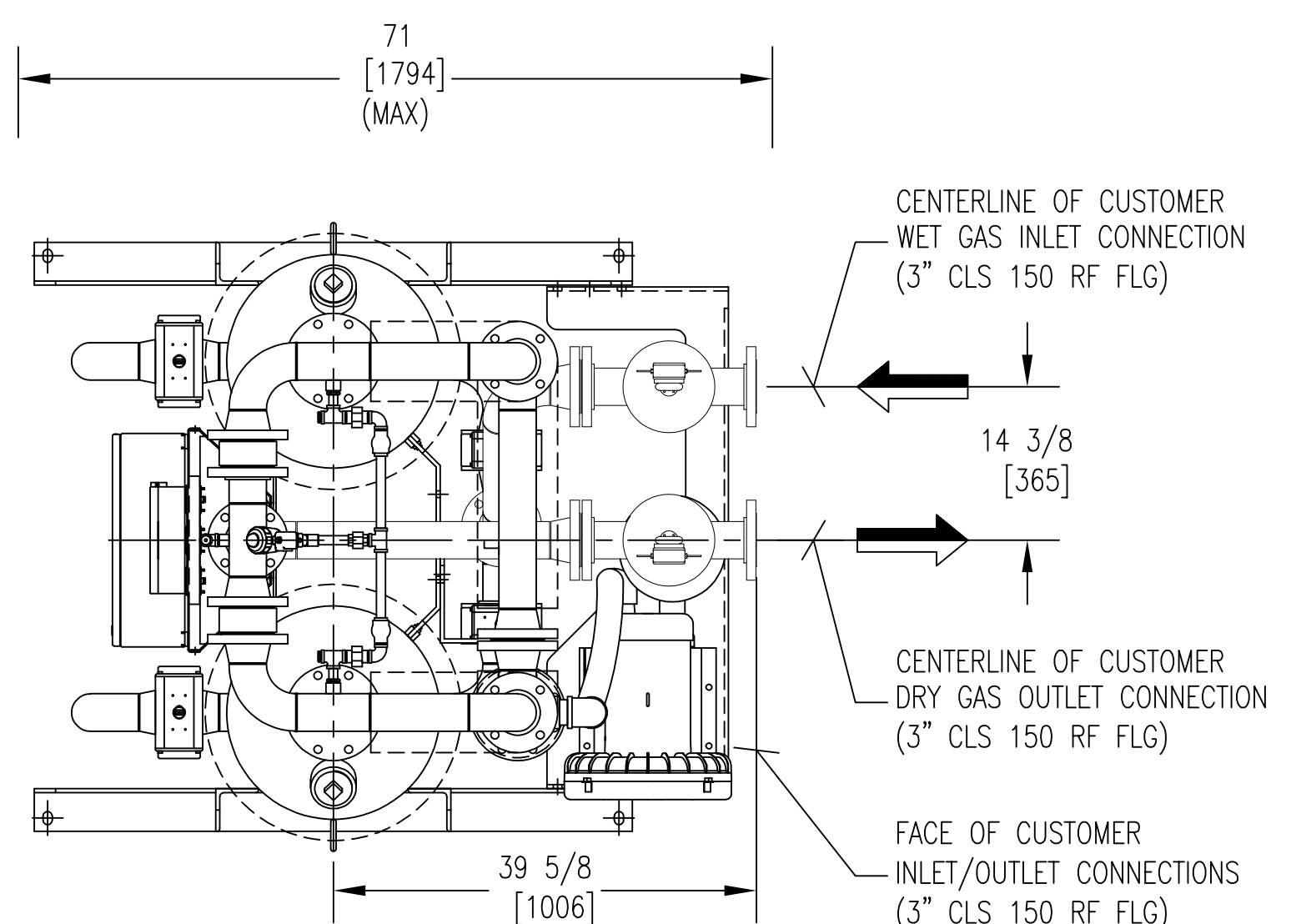

TOP VIEW (F01 PKG OPTIONAL)

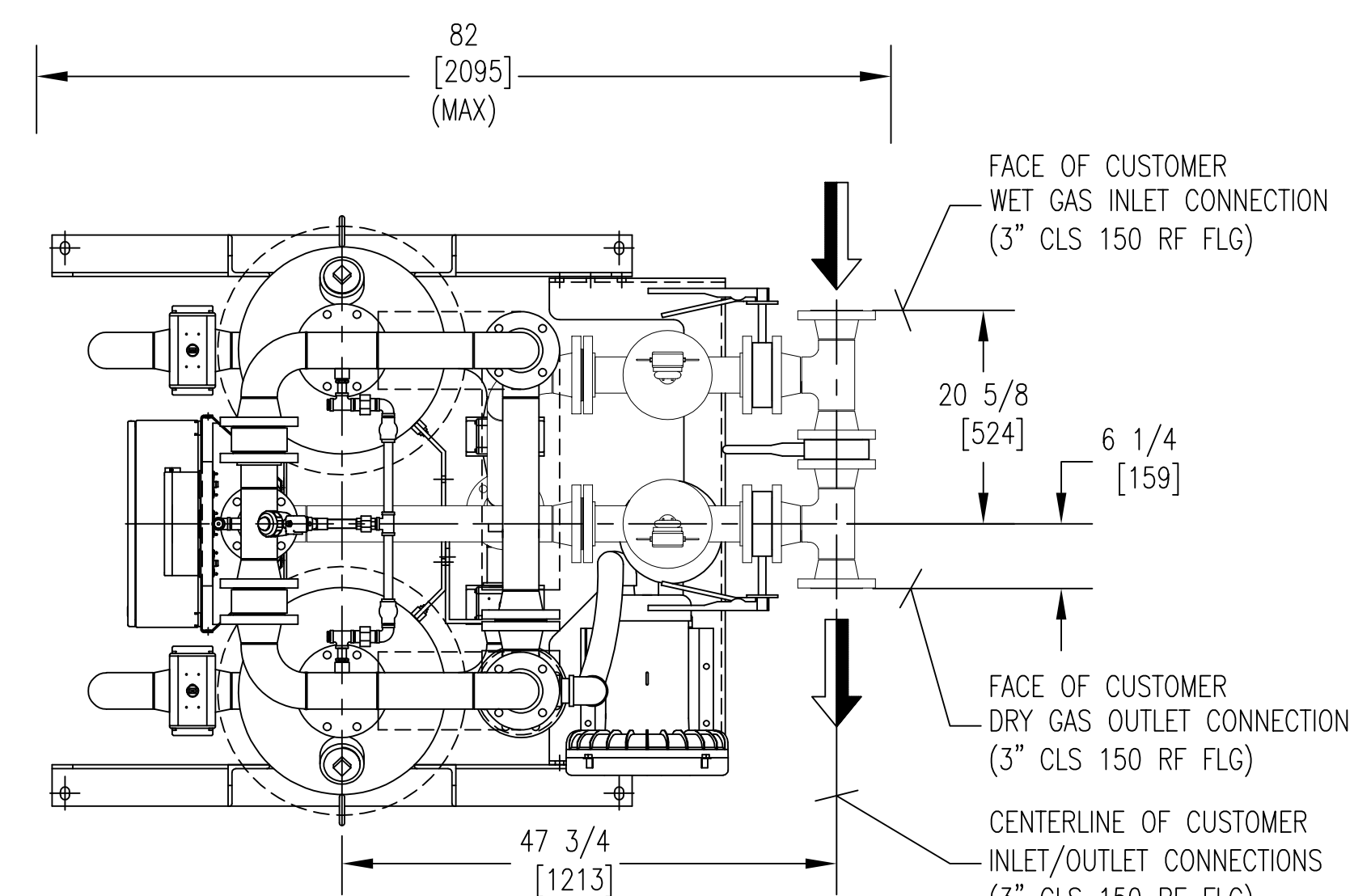

TOP VIEW (F02 PKG OPTIONAL)

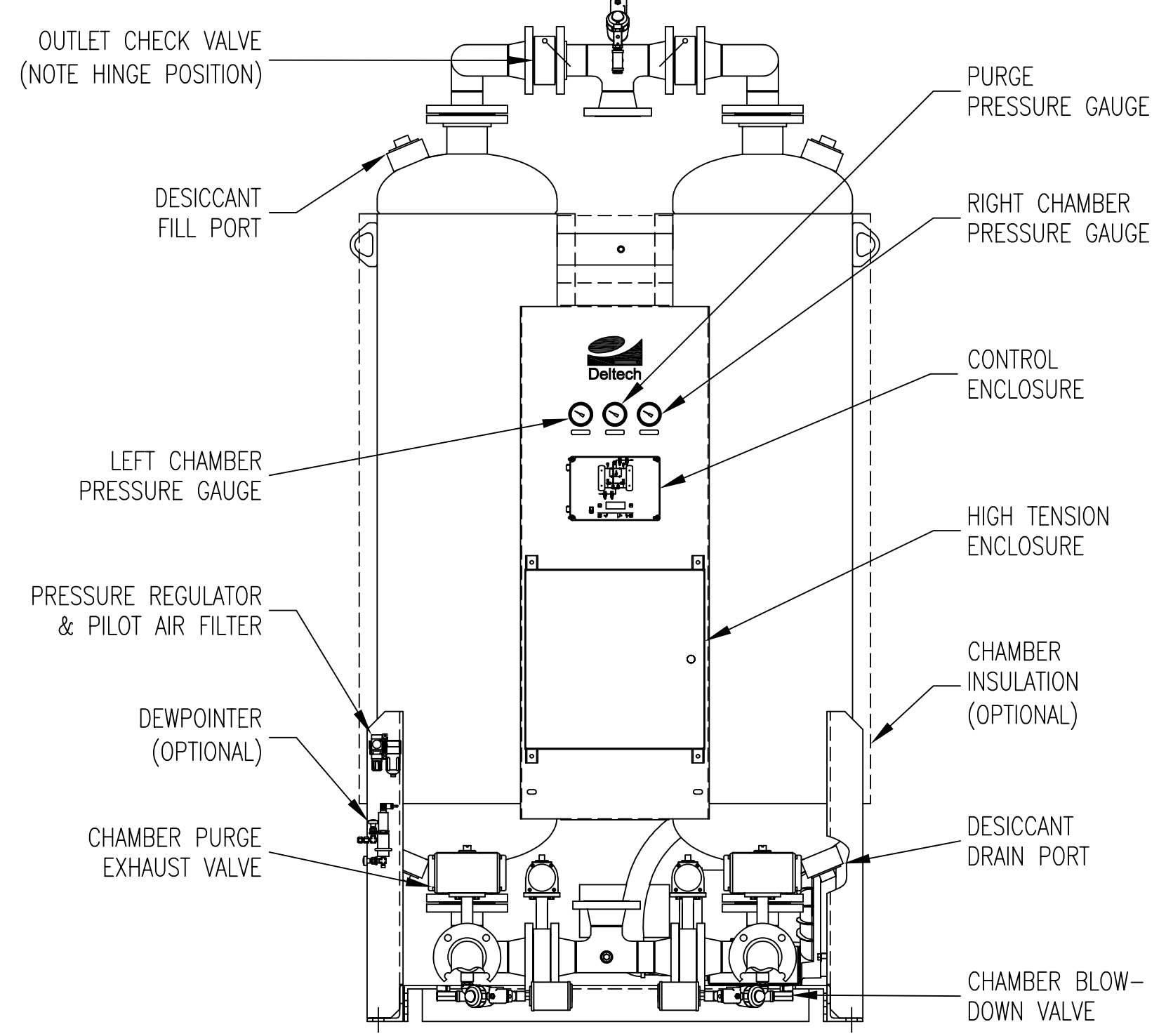

FRONT VIEW

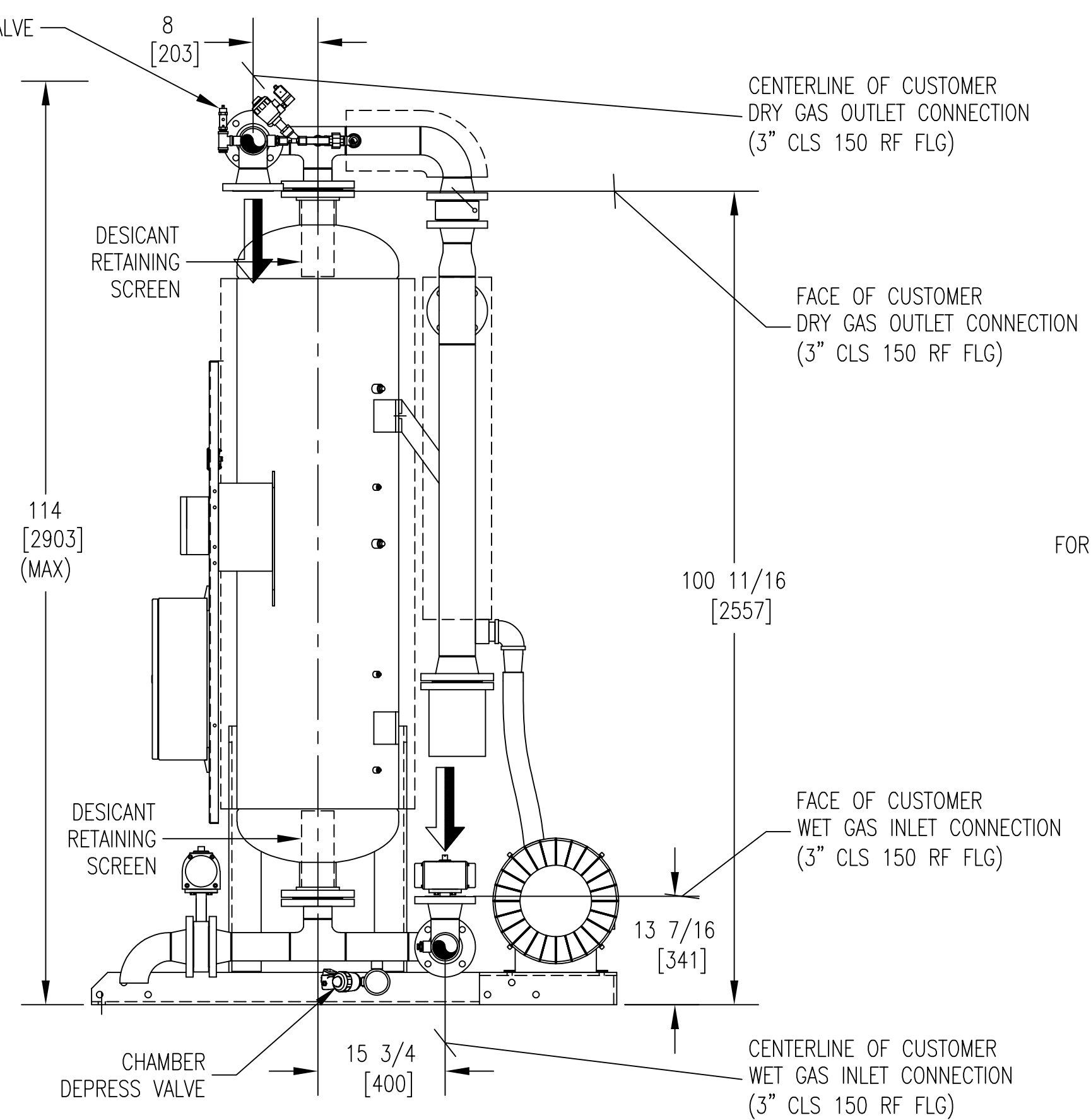

SIDE VIEW (RIGHT CHAMBER REMOVED FOR CLARITY)

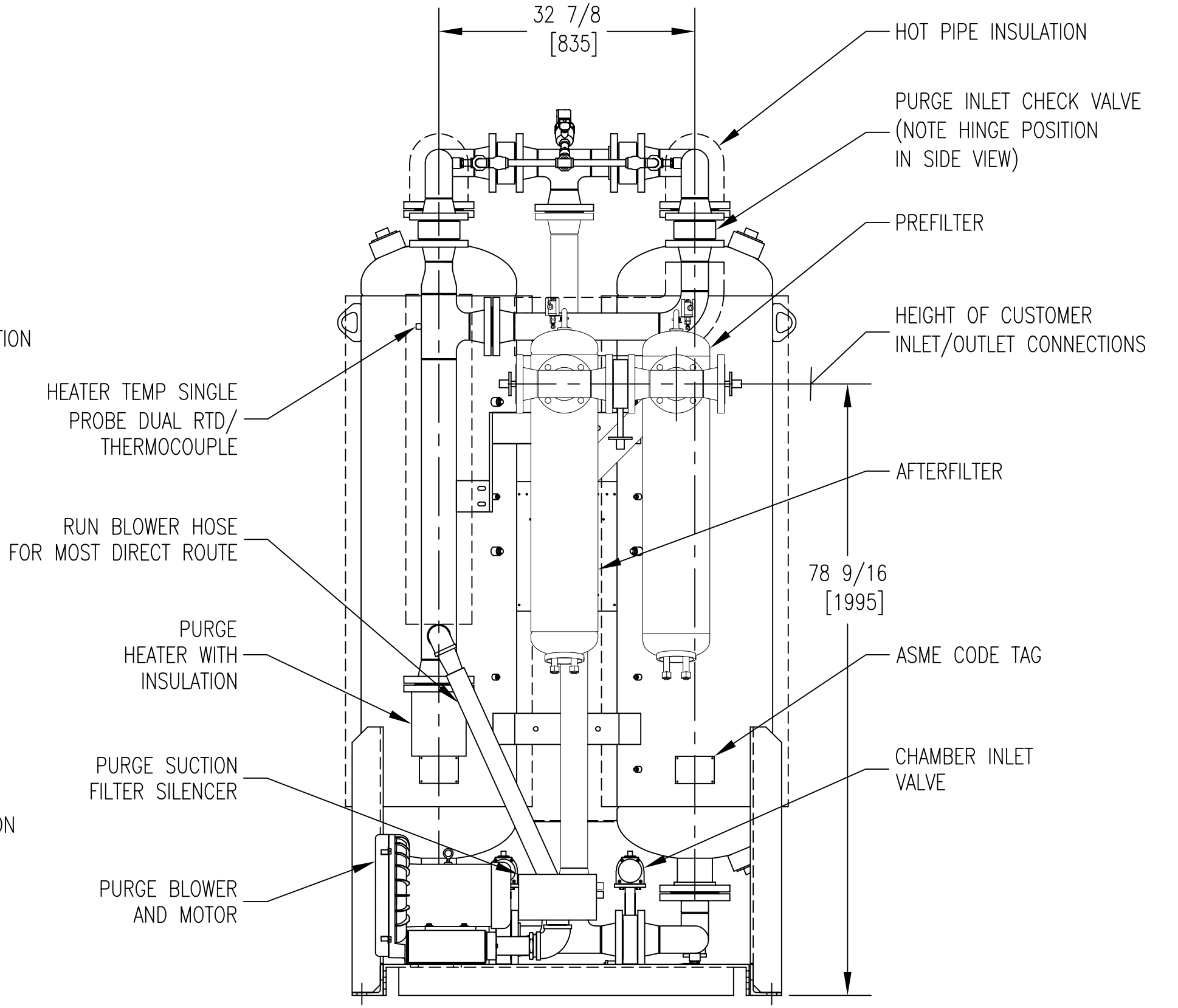

REAR VIEW (F01/F02 PKG OPTIONAL)

- NOTES:
- THIS DRAWING, TOGETHER WITH THE P&ID AND SPECIFICATION SHEET, PROVIDES OPERATING CONDITIONS, SPECIFICATIONS, INSTALLATION, MOUNTING AND CONNECTION REQUIREMENTS.
 - PRESSURE VESSELS ARE DESIGNED AND BUILT IN ACCORDANCE WITH THE CURRENT EDITION AND ADDENDA OF SECTION VIII, DIV. I, OF THE A.S.M.E. CODE FOR UNFIRED PRESSURE VESSELS.
 - ELECTRICAL CONSTRUCTION IS IN ACCORDANCE WITH THE NATIONAL ELECTRICAL CODE.
 - ANCHOR BOLTS ARE TO PROJECT A MINIMUM OF 2" ABOVE THE FOUNDATION. ANCHOR BOLTS SHOULD BE INSTALLED IN SLEEVES TO ALLOW SOME ADJUSTMENT AT TIME OF INSTALLATION.
 - FOR MAINTENANCE PURPOSES, RECOMMENDED CLEARANCE AROUND DRYER IS 4 FEET [1220 MM].
 - IF THE EQUIPMENT IS TO DRY (OR REACTIVATE WITH) A GAS OTHER THAN AIR, THE OUTLETS OF THE SAFETY VALVE, REACTIVATION GAS OUTLET LINE, BLOWDOWN VALVES, ETC. SHALL BE PIPED AWAY TO A SAFE LOCATION (BY PURCHASER). IN PIPING AWAY GAS, DO NOT PIPE UPWARD WITHOUT ADEQUATE ARRANGEMENTS TO PREVENT TRAPPING CONDENSATION.
 - WEIGHTS: SHIPPING WEIGHT 2,339 LBS. (APPROX.)
OPERATING WEIGHT 2,339 LBS. (APPROX.)
1,061 KGS
1,061 KGS
 - WHEN FILTER OPTION IS SUPPLIED, REMOVE FILTER AND FILTER PIPING FOR SHIPPING.

UNLESS OTHERWISE SPECIFIED:		NAME	DATE	UNAUTHORIZED USE, MANUFACTURE, OR REPRODUCTION IN WHOLE OR IN PART IS PROHIBITED. DRAWING DESIGN AND OTHER DISCLOSURES ARE PROPERTY OF:	
DIMENSIONS ARE IN: INCHES/MM		DWN BY	SDM	01/17/05	 deltech-spx.com * DO NOT SCALE. USE DIMENSIONS ONLY *
SURFACE FINISH: N/A ✓		ENG BY	DEH	01/17/05	
TOL. MM INCHES		CHK BY	SDM	01/17/05	
X. - -		APP BY	DEH	01/17/05	
.XX - -		REL BY	SDM	01/17/05	
.XXX - -		MAT NO.	----	SIZE DWG. NO.	REV. SHEET
FRACT: ±1/2 ANG: ±2°				D	0017108-900
SCALE: 1/16 WT: N/A					D 1/1

GENERAL ARRANGEMENT
ZP 900

0017108-900