

ZONE		REV	DESCRIPTION	CHG BY	CHK BY	APP BY	REL BY	DATE
-	A	ADDED TEE FOR 3PS DOWNSTREAM FROM PURGE SAVER.	MHO	DEH	DEH	SDM	04/05/06	
-	B	ADDED TEE FOR 3PS DOWNSTRM FRM PURGE SAVR IN REAR VIEW.	MHO	DEH	DEH	SDM	04/10/06	
-	C	CHANGED FILTER PACKAGES.	SDM	DEH	DEH	SDM	10/10/06	
-	D	REMOVED UNNEEDED DETAIL A	DL	DEH	DEH	SDM	2/22/07	
-	E	CHANGE ELECTRIC PANEL & VALVE	CPG	DPM	DEH	SDM	06/15/10	
B-4	F	ADDED SINGLE PROBE DUAL RTD/THERMOCOUPLE	SOM/BEK	KL	DEH	SOM/BEK	05/30/19	

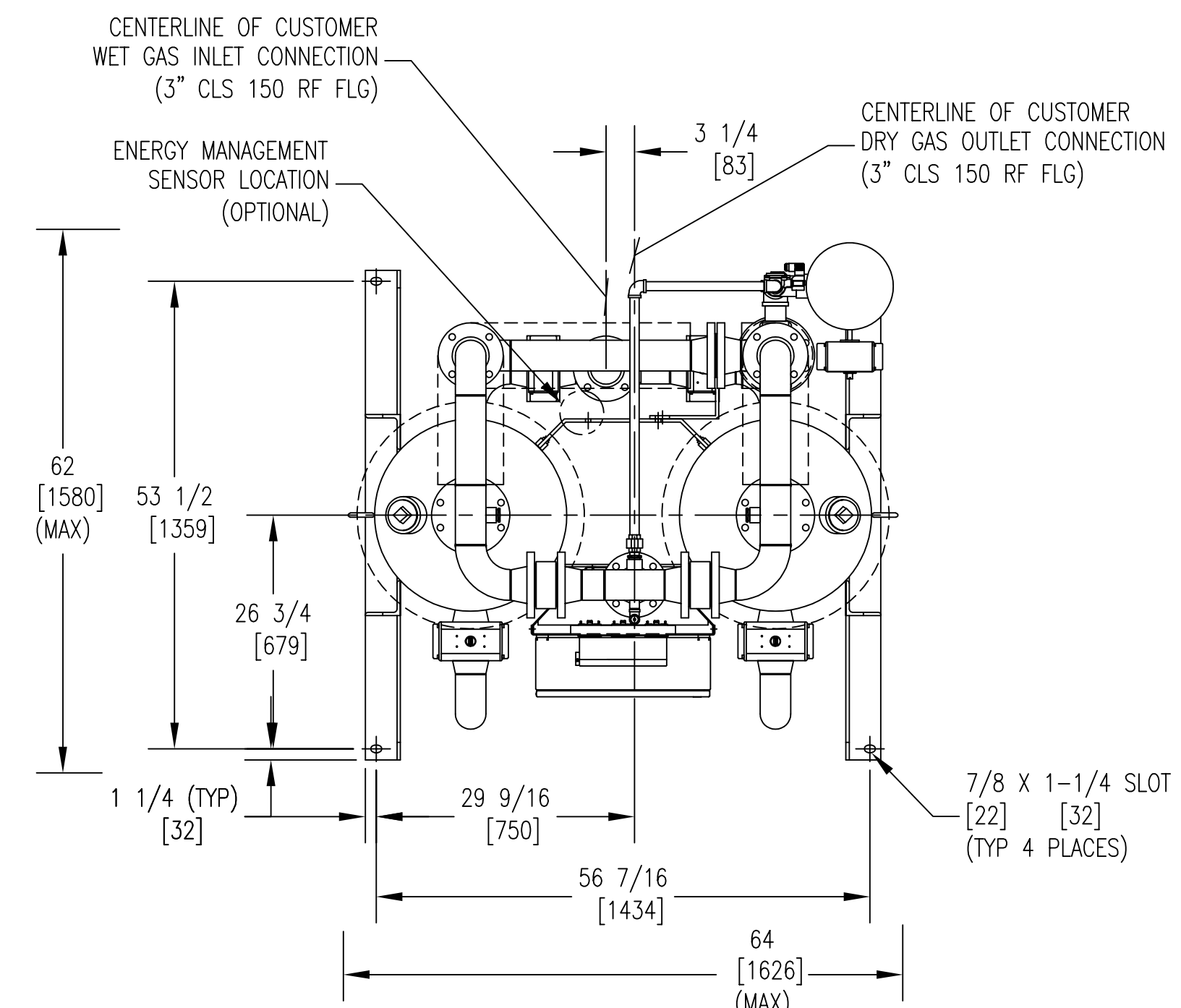

TOP VIEW

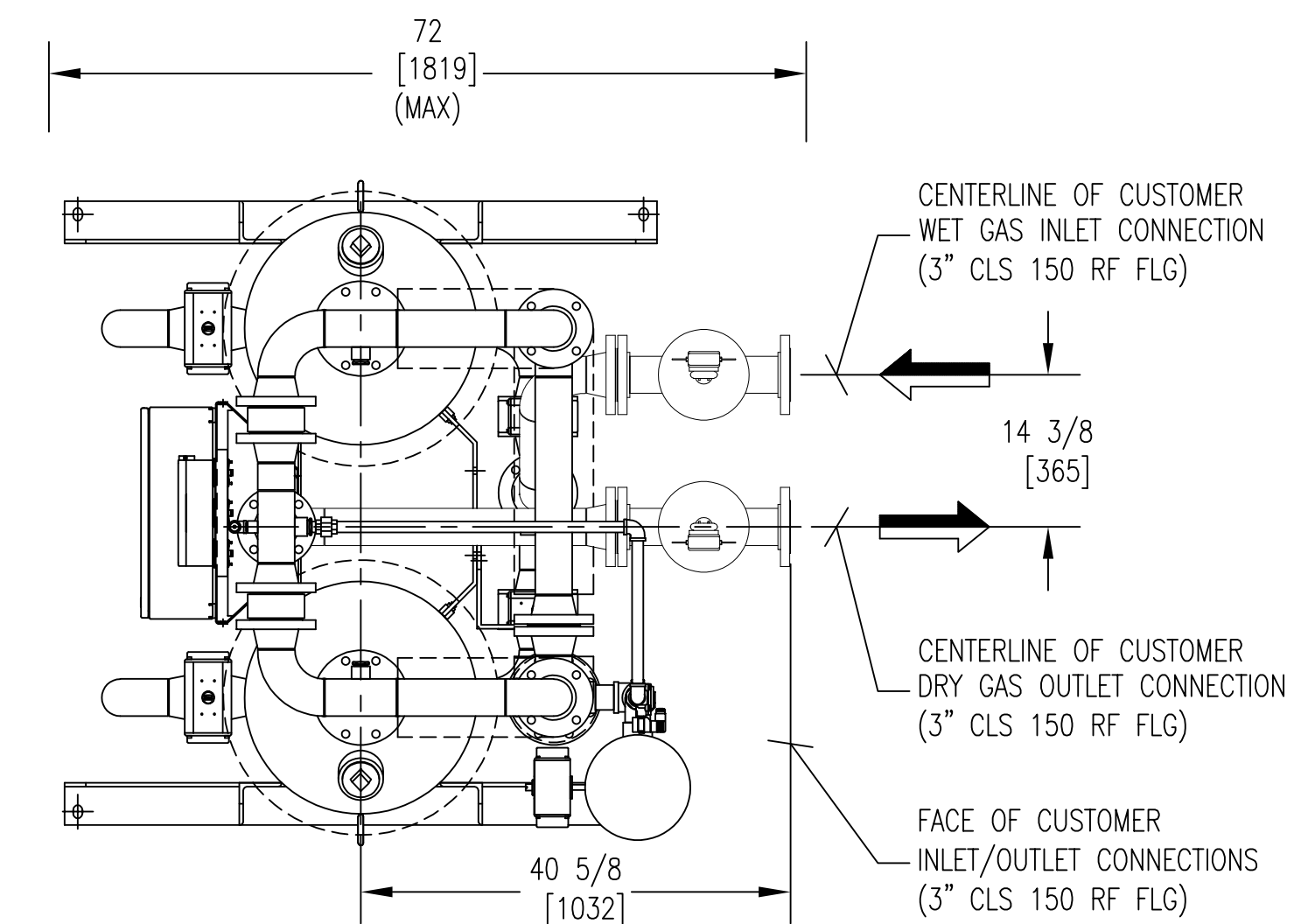

TOP VIEW
(F01 PKG OPTIONAL)

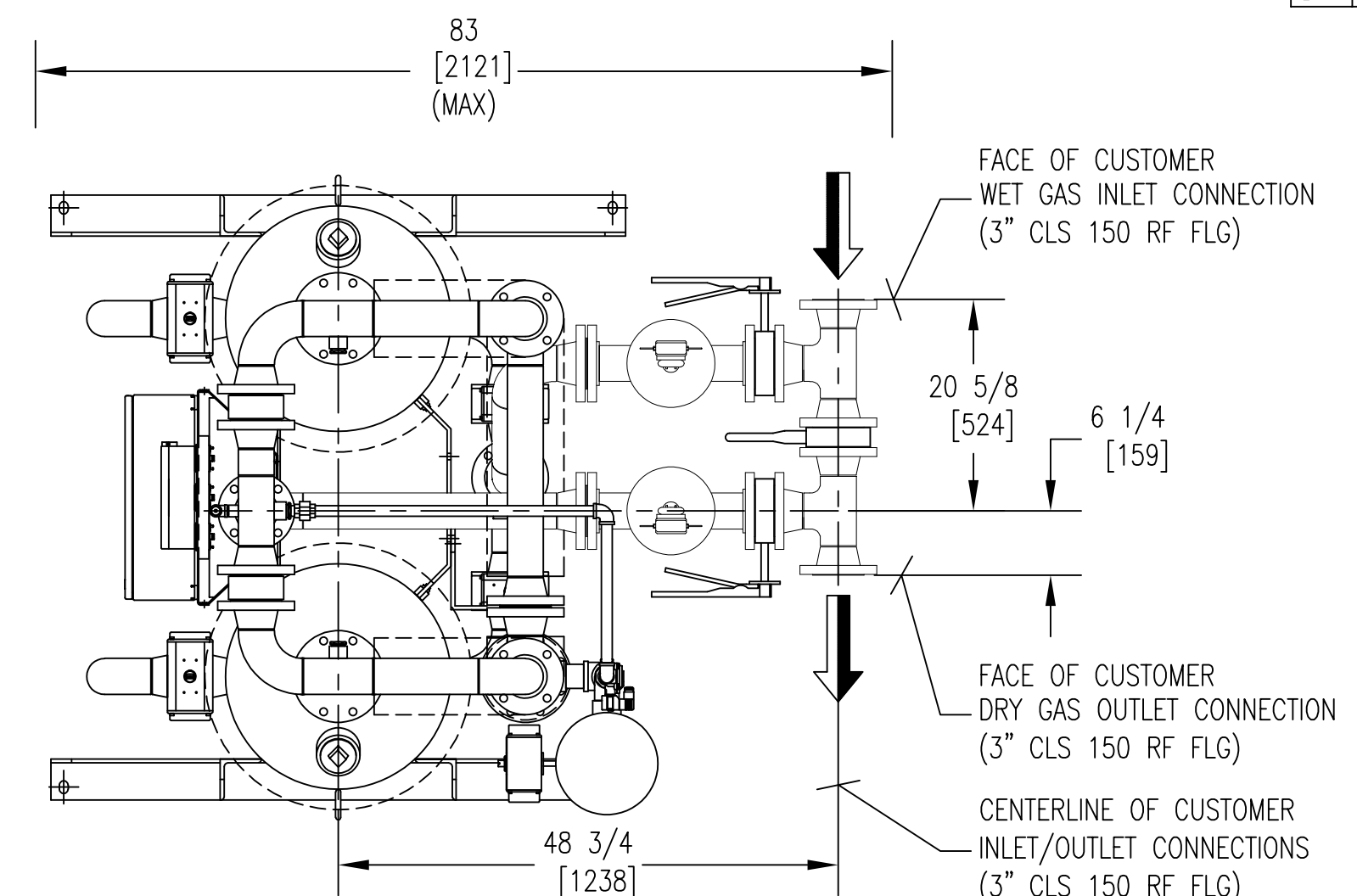

TOP VIEW
(F02 PKG OPTIONAL)

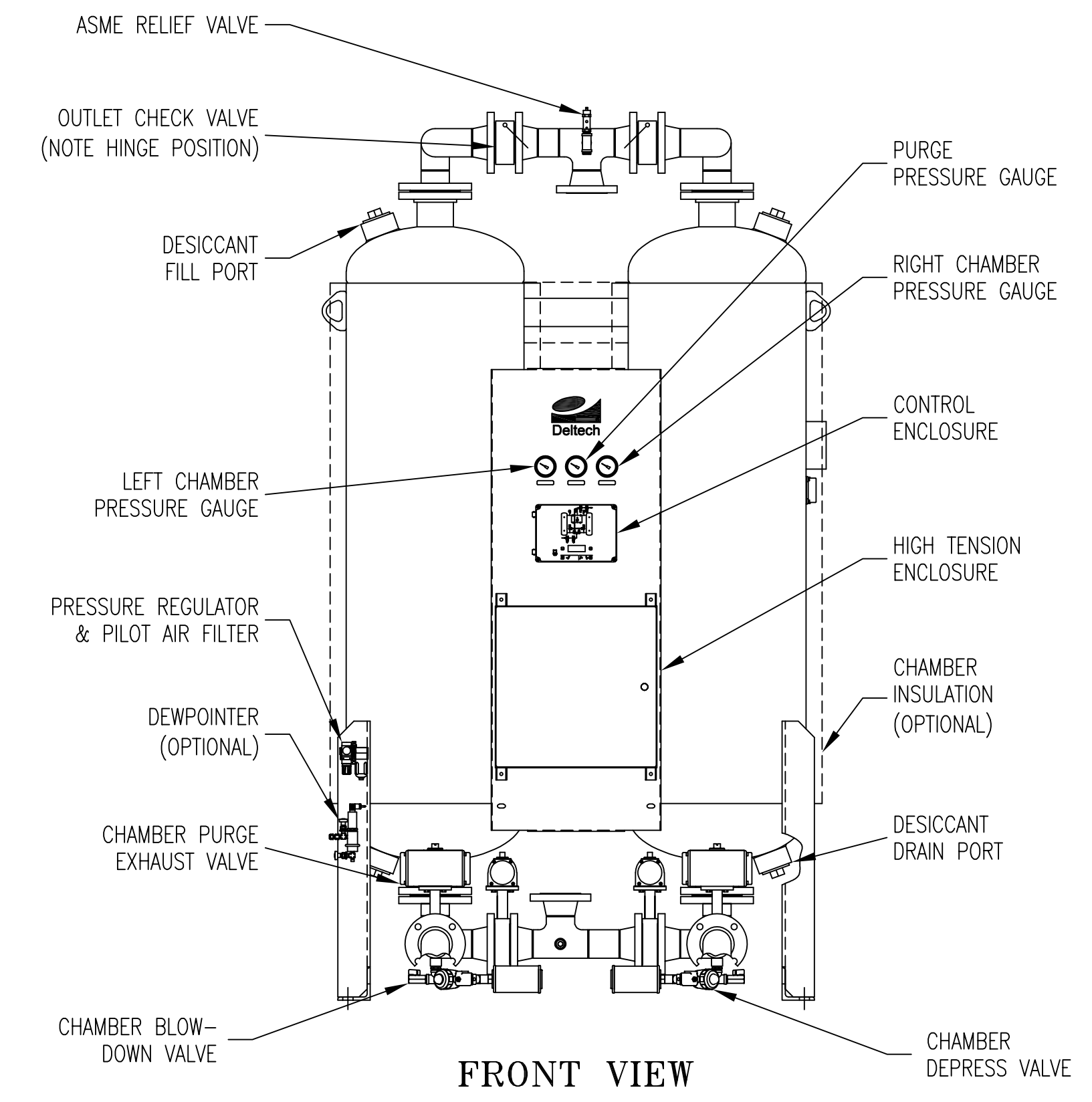

FRONT VIEW

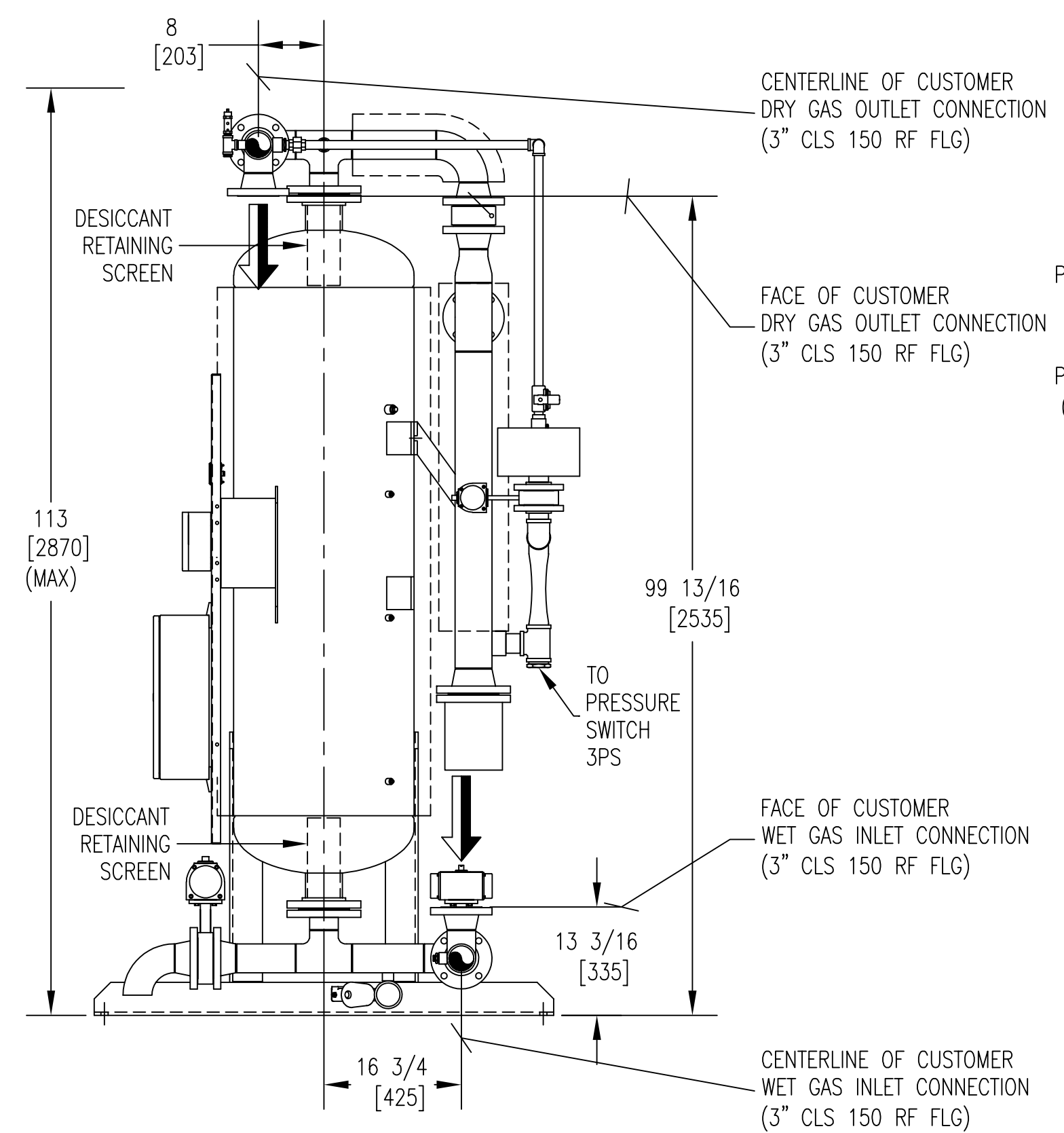

SIDE VIEW
(RIGHT CHAMBER REMOVED FOR CLARITY)

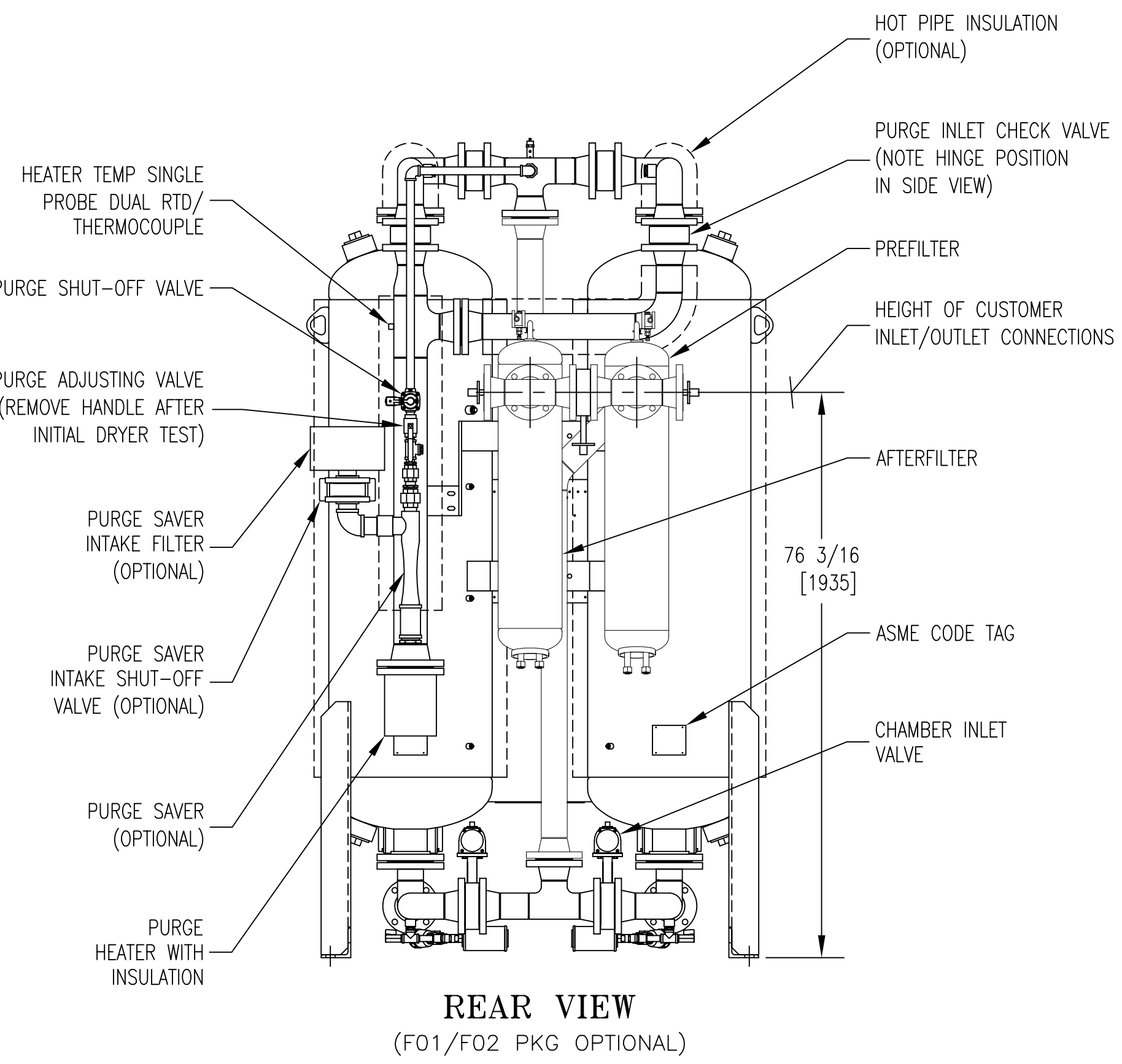

REAR VIEW
(F01/F02 PKG OPTIONAL)

- NOTES:
- THIS DRAWING, TOGETHER WITH THE P&ID AND SPECIFICATION SHEET, PROVIDES OPERATING CONDITIONS, SPECIFICATIONS, INSTALLATION, MOUNTING AND CONNECTION REQUIREMENTS.
 - PRESSURE VESSELS ARE DESIGNED AND BUILT IN ACCORDANCE WITH THE CURRENT EDITION AND ADDENDA OF SECTION VIII, DIV. I, OF THE A.S.M.E. CODE FOR UNFIRED PRESSURE VESSELS.
 - ELECTRICAL CONSTRUCTION IS IN ACCORDANCE WITH THE NATIONAL ELECTRICAL CODE.
 - ANCHOR BOLTS ARE TO PROJECT A MINIMUM OF 2" ABOVE THE FOUNDATION. ANCHOR BOLTS SHOULD BE INSTALLED IN SLEEVES TO ALLOW SOME ADJUSTMENT AT TIME OF INSTALLATION.
 - FOR MAINTENANCE PURPOSES, RECOMMENDED CLEARANCE AROUND DRYER IS 4 FEET [1220 MM].
 - IF THE EQUIPMENT IS TO DRY (OR REACTIVATE WITH) A GAS OTHER THAN AIR, THE OUTLETS OF THE SAFETY VALVE, REACTIVATION GAS OUTLET LINE, BLOWDOWN VALVES, ETC. SHALL BE PIPED AWAY TO A SAFE LOCATION (BY PURCHASER). IN PIPING AWAY GAS, DO NOT PIPE UPWARD WITHOUT ADEQUATE ARRANGEMENTS TO PREVENT TRAPPING CONDENSATION.
 - WEIGHTS: SHIPPING WEIGHT 2,816 LBS. (APPROX.)
OPERATING WEIGHT 1,277 KGS (APPROX.)
1,277 KGS (APPROX.)
 - WHEN FILTER OPTION IS SUPPLIED, REMOVE FILTER AND FILTER PIPING FOR SHIPPING.

UNLESS OTHERWISE SPECIFIED:		NAME	DATE	UNAUTHORIZED USE, MANUFACTURE, OR REPRODUCTION IN WHOLE OR IN PART IS PROHIBITED. DRAWING DESIGN AND OTHER DISCLOSURES ARE PROPERTY OF:
DIMENSIONS ARE IN: INCHES/MM		DWN BY	SDM	12/20/04
SURFACE FINISH: N/A ✓		ENG BY	DEH	12/20/04
TOL.	MM	CHK BY	SDM	12/20/04
.X	-	APP BY	DEH	12/20/04
.XX	-	REL BY	SDM	12/20/04
.XXX	-	MAT NO.	----	SIZE DWG. NO.
FRACT: ±1/2	ANG: ±2°	SCALE: 1/16	WT: N/A	D 0027008-1050



GENERAL ARRANGEMENT
RP 1050

REV. SHEET
F 1/1