

4

3

2

1

- REVISIONS -

ZONE	REV	DESCRIPTION	CHG BY	CHK BY	APP BY	REL BY	DATE
-	A	UPDATE PILOT AIR FILTER TO NGF STYLE.	NDM	SDM	DEH	SDM	07/02/14
-	B	313 PRE AND AFTERFILTERS WERE 312.	SDM	DEH	DEH	SDM	07/02/15

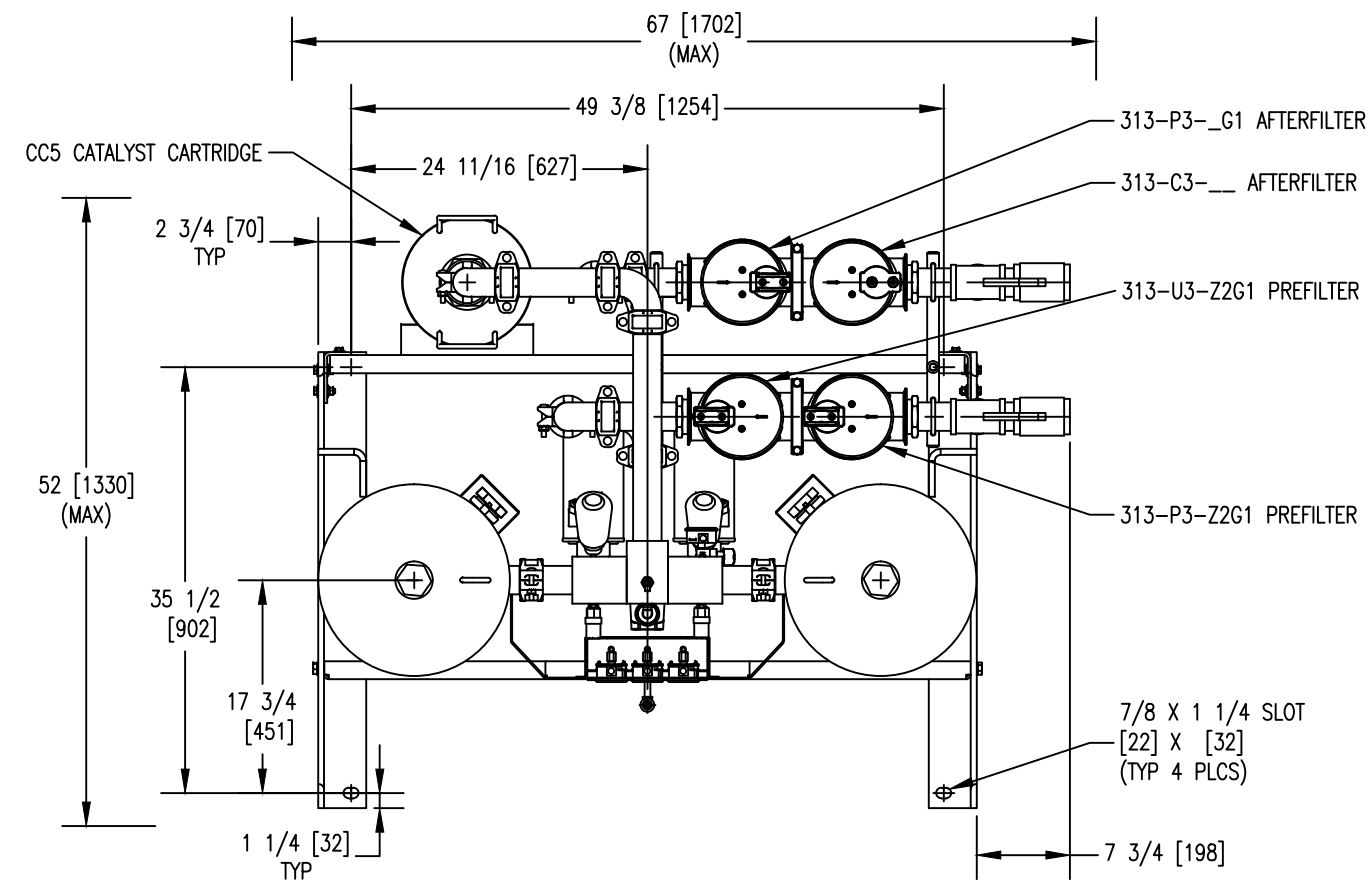

TOP VIEW

NOTES:

- THIS DRAWING, TOGETHER WITH P&ID AND SPECIFICATION SHEET, PROVIDES OPERATING CONDITIONS, SPECIFICATIONS, INSTALLATION, MOUNTING AND CONNECTION REQUIREMENTS.
- DESICCANT DRYER CHAMBERS ARE DESIGNED AND BUILT IN ACCORDANCE WITH THE CURRENT CODE AND ADDENDA OF SECTION VIII, DIV. 1, OF THE A.S.M.E. CODE FOR UNFIRED PRESSURE VESSELS.
- ELECTRICAL CONSTRUCTION IS IN ACCORDANCE WITH THE NATIONAL ELECTRICAL CODE.
- ANCHOR BOLTS ARE TO PROJECT A MINIMUM OF 2" ABOVE THE FOUNDATION. ANCHOR BOLTS SHOULD BE INSTALLED IN SLEEVES TO ALLOW SOME ADJUSTMENT AT TIME OF INSTALLATION.
- EXTERNAL PIPING MUST BE RIGIDLY MOUNTED AND NOT SUPPORTED BY THIS UNIT.
- FOR MAINTENANCE PURPOSES, RECOMMENDED CLEARANCE AROUND UNIT IS 4 FEET [1220 MM].
- BREATHING AIR PURIFIERS CANNOT BE SUPPLIED WITH, OR REACTIVATED BY, ANY GAS OTHER THAN AIR. DO NOT PIPE PURGE EXHAUST TO A REMOTE LOCATION WITHOUT CONSULTING THE FACTORY.

8. CUSTOMER SHOULD REQUEST A COPY OF QMS-013 IF PLANNING ON STORING UNIT LONG TERM BEFORE PLACING INTO SERVICE.

9. OPERATING CONDITIONS:

INLET AIR PRESSURE:

MAXIMUM:	150 PSIG	10.5 KGF/CM2
MINIMUM:	60 PSIG	4.2 KGF/CM2
DESIGN:	100 PSIG	7.0 KGF/CM2

INLET AIR TEMPERATURE:

MAXIMUM:	140 °F	60 °C
MINIMUM:	35 °F	1.7 °C
DESIGN:	100 °F	37.8 °C

AMBIENT AIR TEMPERATURE:

MAXIMUM:	120 °F	49 °C
MINIMUM:	35 °F	1.7 °C
DESIGN:	100 °F	37.8 °C

AIR FLOW:

INLET:	450 SCFM @ 100 PSIG & 100 °F
	765 M3/HR @ 7.0 KGF/CM2 & 37.8 °C
OUTLET:	375 SCFM @ 100 PSIG & 100 °F
	637 M3/HR @ 7.0 KGF/CM2 & 37.8 °C

10. SUPPLY POWER:

85-264 VAC, 1 PH, 47-63 HZ OR 11.5-28 VDC

11. AVAILABLE OPTIONS:

- L2 - ADVANCED CONTROLLER WITH:
  - VACUUM FLUORESCENT TEXT DISPLAY
  - PURGE SAVER AUTOMATIC ENERGY SAVINGS
  - HIGH INLET AIR TEMPERATURE ALARM
  - LOW INLET AIR PRESSURE ALARM
- N7 - NEMA7 ELECTRICAL RATING
- CB - COPPER INSTRUMENT TUBING
- SS - STAINLESS STEEL INSTRUMENT TUBING, FITTINGS, AND GAUGES
- AZ1 - CO MONITOR
- AZ2 - CO & OXYGEN MONITOR
- AZ3 - CO & DEW POINT MONITOR
- AZ4 - CO, OXYGEN, & DEW POINT MONITOR
- 10 - SSPC-SP10 SANDBLAST & EPOXY PAINT

12. WEIGHTS: SHIPPING WEIGHT

1560 LBS. (APPROX.)	710 KGS
OPERATING WEIGHT	1560 LBS. (APPROX.)
	710 KGS

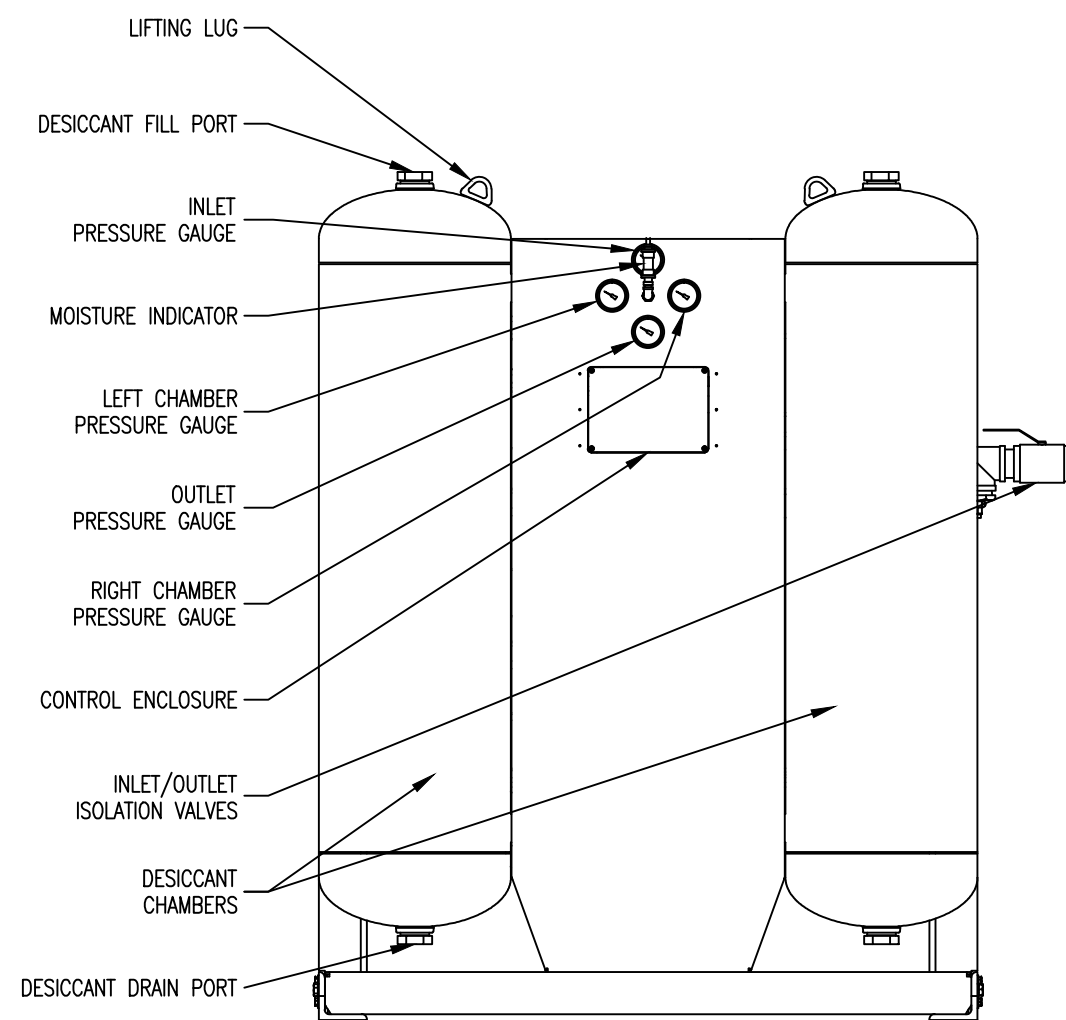

FRONT VIEW

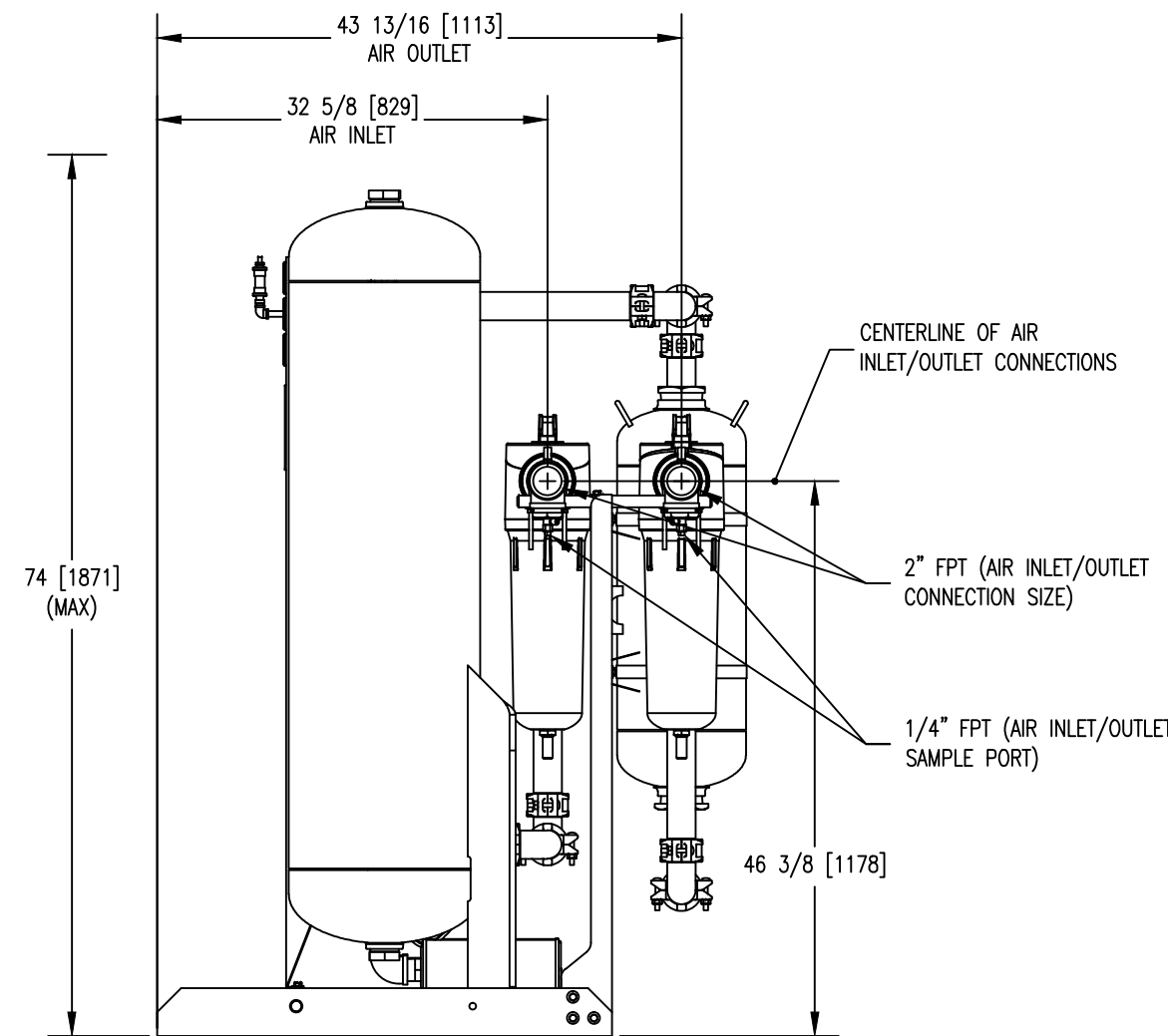

SIDE VIEW

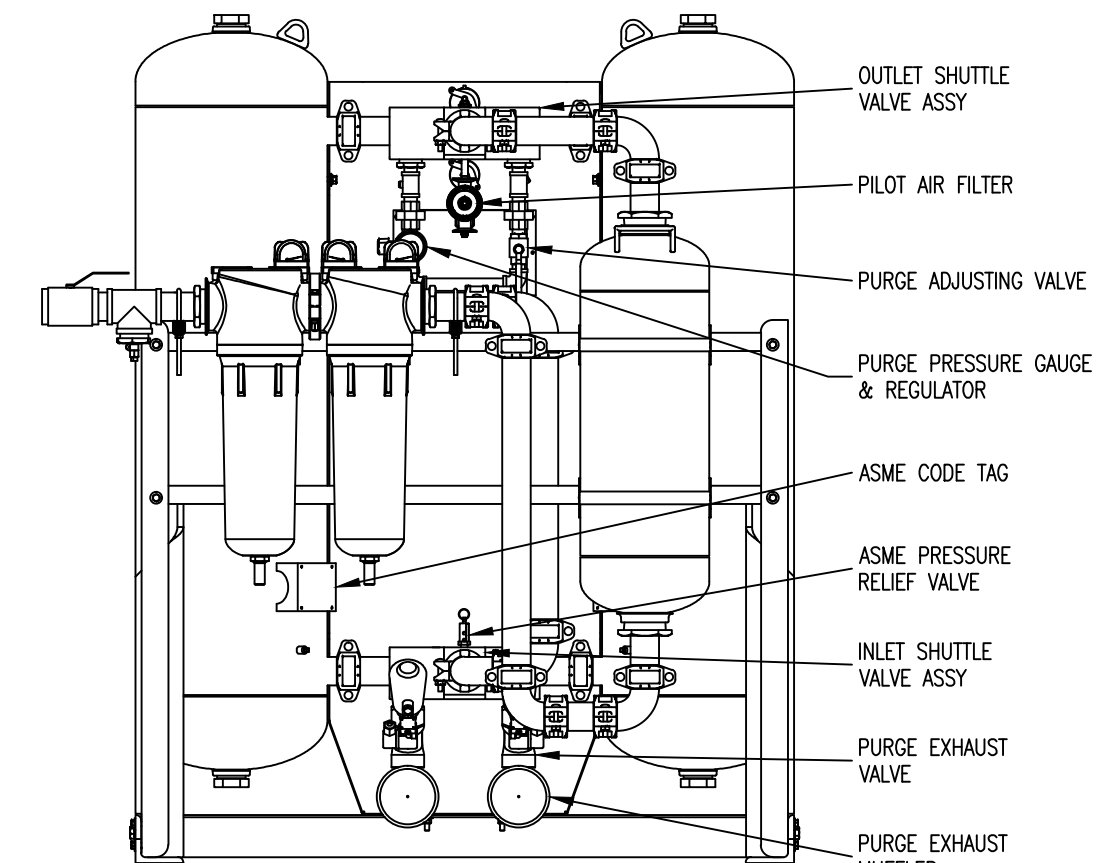

REAR VIEW

UNLESS OTHERWISE SPECIFIED:		NAME	DATE	UNAUTHORIZED USE, MANUFACTURE, OR REPRODUCTION IN WHOLE OR IN PART IS PROHIBITED. DRAWING DESIGN AND OTHER DISCLOSURES ARE PROPERTY OF:	
DIMENSIONS ARE IN: INCHES/MM		DWN BY	MDB	04/30/14	<b>Deltech</b> * DO NOT SCALE. USE DIMENSIONS ONLY *
SURFACE FINISH: N/A ✓		ENG BY	SDM	04/30/14	
TOL.	MM	INCHES	CHK BY	SDM	<b>GENERAL ARRANGEMENT</b> DM 375, BREATHING AIR PURIFIER, NGF
.X	-	-	APP BY	SDM	
.XX	-	-	REL BY	SDM	
.XXX	-	-	MAT NO.	----	SIZE DWG. NO.
FRACT: ±1/2 ANG: ±2°				C	0072208-375
SCALE: 1/16 WT: N/A				B	1/1

4

3

2

1