

4

3

2

1

REVISIONS						
ZONE	REV	DESCRIPTION	ECN #	CHG BY	DATE	APP'D

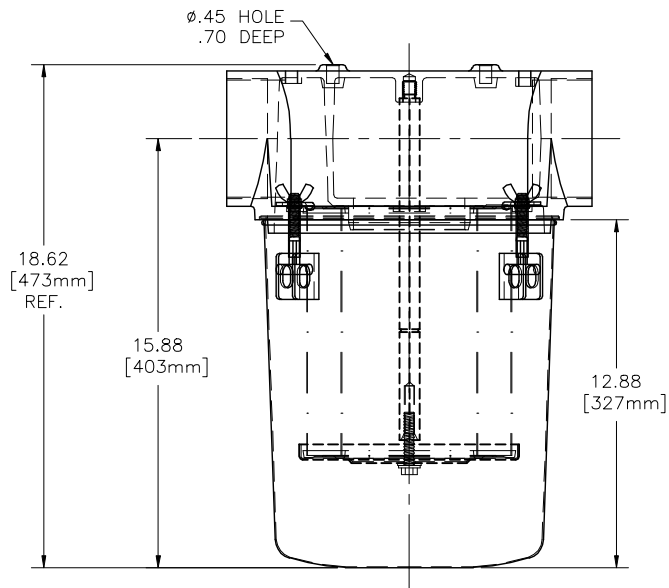
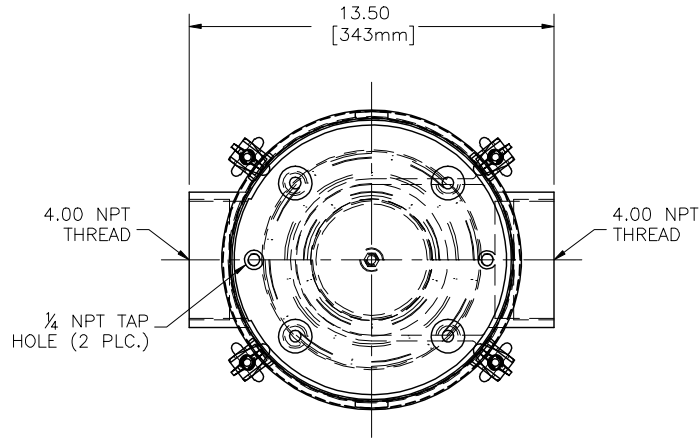

REPLACEMENT ELEMENT# 235P	
MATERIAL	POLYESTER
CFM FLOW	570
SURFACE AREA	8.3 SQ. FT.
I.D.	4.75
O.D.	7.88
HEIGHT	9.63

MODEL#	HOUSING MATERIAL	FINISH
CT-235P-400C	CASTING/CARBON STEEL	CASTING/BLACK PAINT

The information contained herein is confidential and the property of Solberg Manufacturing Inc. and it is furnished to you with the expressed understanding that it will not be reproduced, copied in any manner, loaned or otherwise transferred to others entirely or in part, nor used for any purpose other than for which it was furnished. It will be returned upon request to Solberg Manufacturing Inc. The above restriction is in addition to, and does not in any way alter, any other restrictions which may apply to the information contained herein. The Illinois Circuit Court, Cook County Division has exclusive jurisdiction over any prosecution that may be necessary to uphold these restrictions.



SOLBERG MANUFACTURING INC.  
1151 W. ARDMORE AVE.  
ITASCA, IL 60143  
630/773-1363

DESCRIPTION:  
CT-235P-400C

UNLESS OTHERWISE SPECIFIED:  
-DIMENSIONS ARE IN INCHES  
-REF: APPROXIMATE DIMENSIONS, NO TOLERANCES APPLY  
-TOLERANCES ARE:  
DECIMALS: .XX ±.25  
.XXX ±.125  
ANGLES ±2'

CUSTOMER APPROVAL:

SALES REP.: G.KAM	
APPROVALS	DATE
DRAWN: CRW	12/15/06
APPROVED:	

SHEET: 1 of 1	SHEET SIZE: C	SCALE: 1:3.5
DRAWING NUMBER: SD12562	REV: —	

4

3

2

1