

REV	DESCRIPTION	ECN #	CHG BY	DATE	APP'D
A	CONVERTED TO 3D	-	EZR	04/20/16	CRW

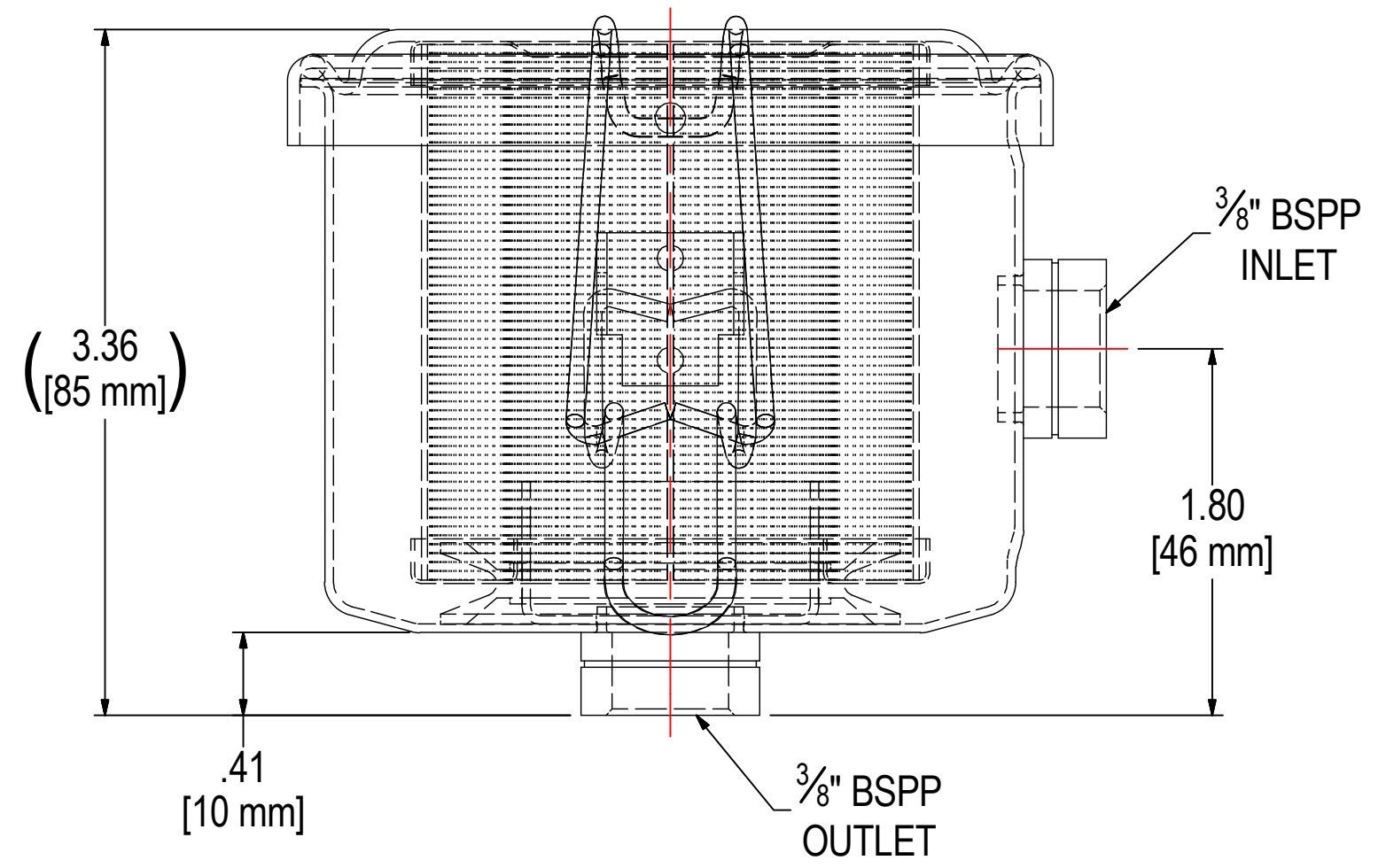
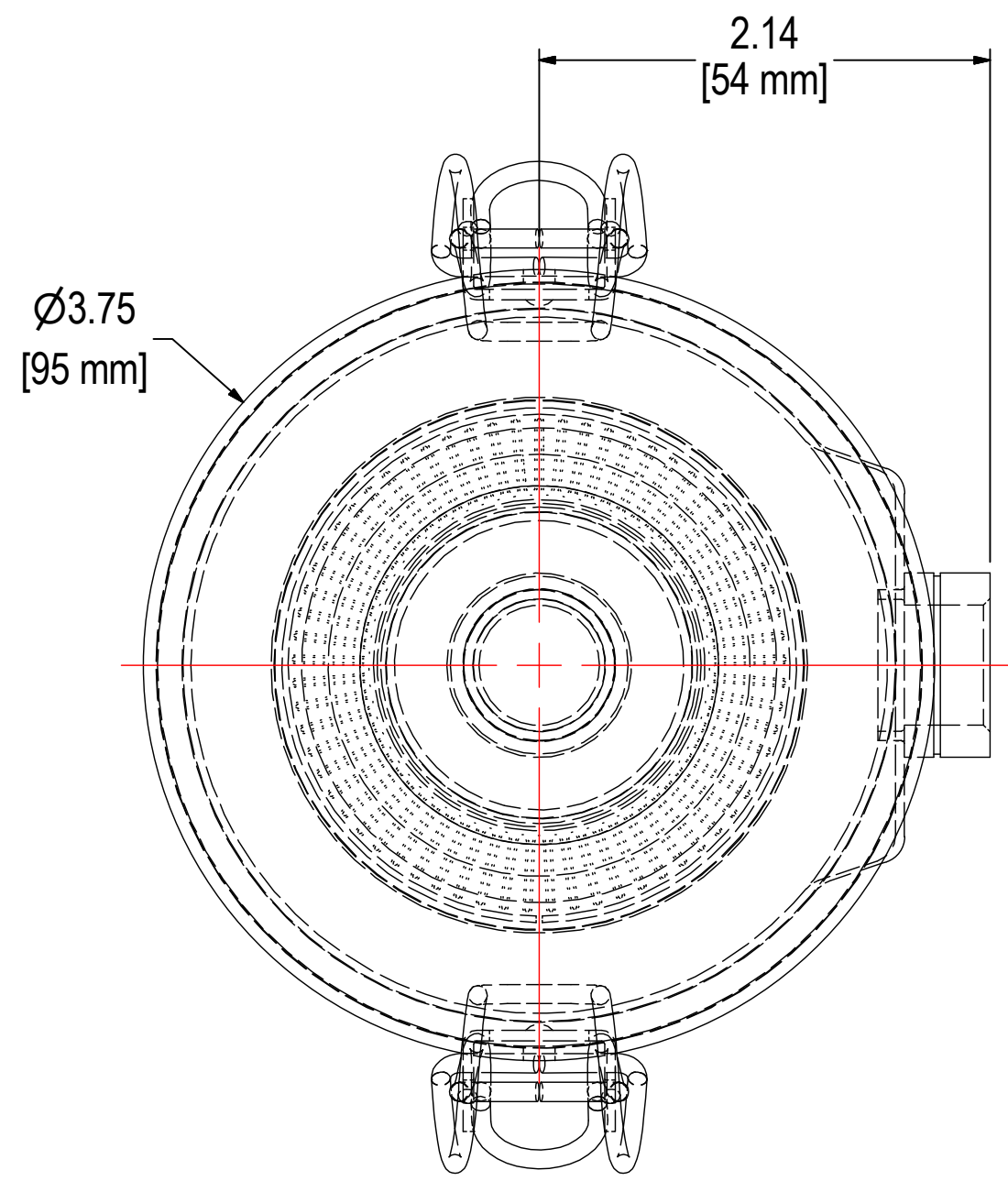

ELEMENT SPECS		
PART NUMBER	824	
MATERIAL	Paper	
FLOW RATE	25 CFM	42 m ³ /hr
SURFACE AREA	0.9 ft ²	0.1 m ²
I.D.	1.50"	38mm
O.D.	2.50"	64mm
HEIGHT	2.69"	68mm

MODEL #: CSL-824-039HCB	MATERIAL: CARBON STEEL	FINISH: BLACK POWDER
MODEL NUMBER: CSL-824-039HCB	SHEET: 1 OF 1	
DESCRIPTION: CSL-824-039HCB, BLACK		
PROJECT:	DRAWN BY: CRW	APPROVED BY: M.C.
	DATE: 6/13/2016	DATE: 5/27/2014
		REV: A

SOLBERG
Filtration • Separation • Silencing
630.773.1363 • www.solbergmfg.com

THE INFORMATION CONTAINED HEREIN IS CONFIDENTIAL AND THE PROPERTY OF SOLBERG MANUFACTURING INC. AND IT IS FURNISHED TO YOU WITH THE EXPRESS UNDERSTANDING THAT IT WILL NOT BE REPRODUCED, COPIED IN ANY MANNER, LOANED OR OTHERWISE TRANSFERRED TO OTHERS ENTIRELY OR IN PART, NOR USED FOR ANY PURPOSE OTHER THAN FOR WHICH IT WAS FURNISHED. IT WILL BE RETURNED UPON REQUEST TO SOLBERG MANUFACTURING INC. THE ABOVE RESTRICTION IS IN ADDITION TO, AND DOES NOT IN ANY WAY ALTER, ANY OTHER RESTRICTIONS WHICH MAY APPLY TO THE INFORMATION CONTAINED HEREIN.

TOLERANCES
DIMENSIONS ARE FOR REFERENCE ONLY. ALL DIMENSIONS ARE SUBJECT TO CHANGE UPON PRODUCTION.
UNLESS OTHERWISE SPECIFIED:
-DIMENSIONS ARE IN INCHES
-REF: APPROXIMATE DIMENSIONS, NO TOLERANCES APPLY
-FINISH: BREAK EDGES TO .005-.020 RADIUS/CHAMFER