

REV	DESCRIPTION	ECN #	CHG BY	DATE	APP'D
A	UPDATED TO 3D	17495	NAD	10/24/19	EZR

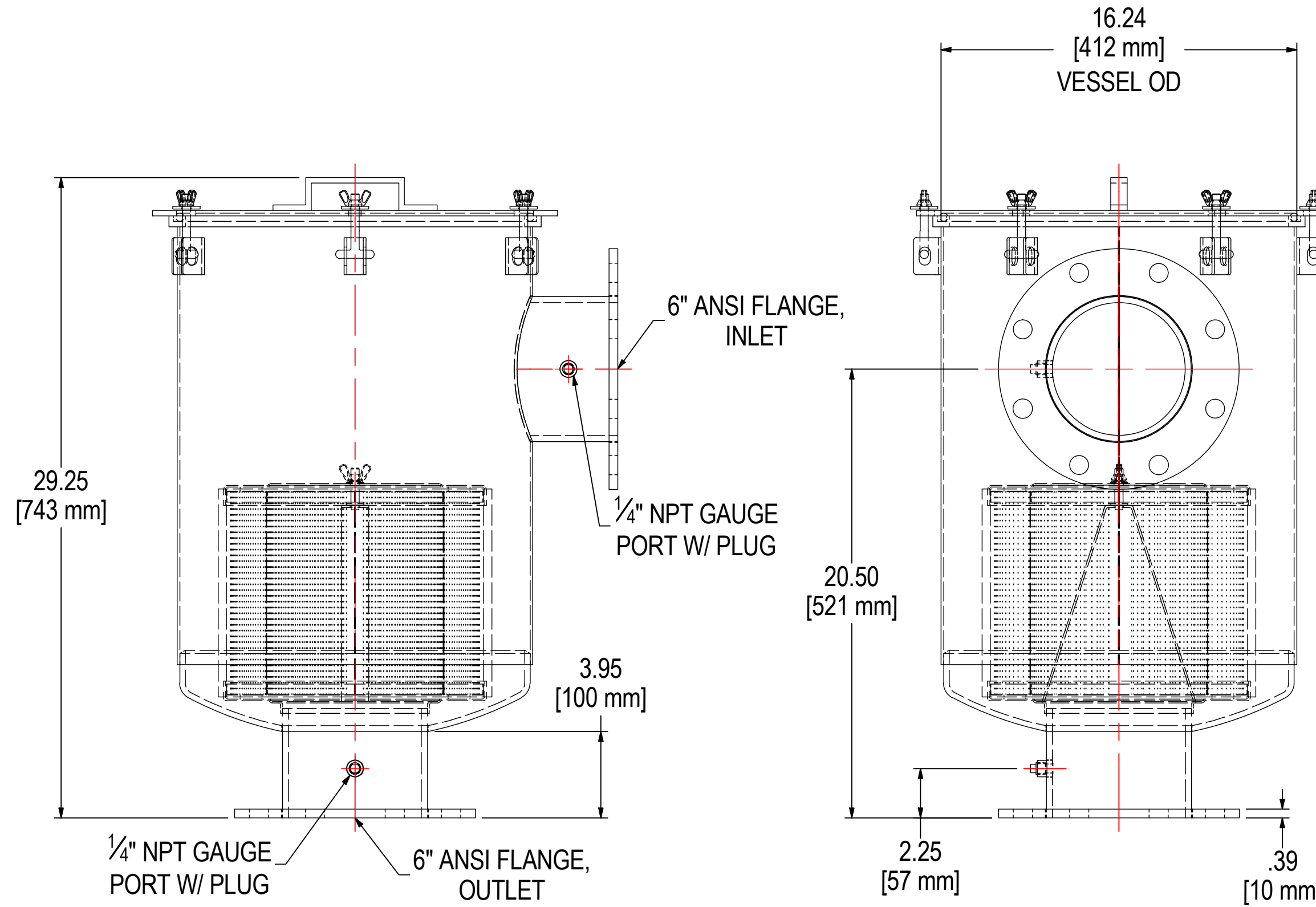

ELEMENT SPECS		
PART NUMBER	275P	
MATERIAL	POLYESTER	
FLOW RATE	1100 CFM	1869 m ³ /hr
SURFACE AREA	19.8 ft ²	1.8 m ²
I.D.	8.00"	203mm
O.D.	11.75"	298mm
HEIGHT	9.68"	246mm

MODEL #: CSL-275P-600F	MATERIAL: CARBON STEEL	FINISH: BLACK RAL 9005
MODEL NUMBER: CSL-275P-600F	SHEET: 1 OF 1	
DESCRIPTION: CSL-275P-600F, BLACK RAL 9005		
PROJECT: SD10314	DRAWN BY: CMA DATE: 11/12/2010	APPROVED BY: M.C. DATE: 11/12/2010
		REV: A

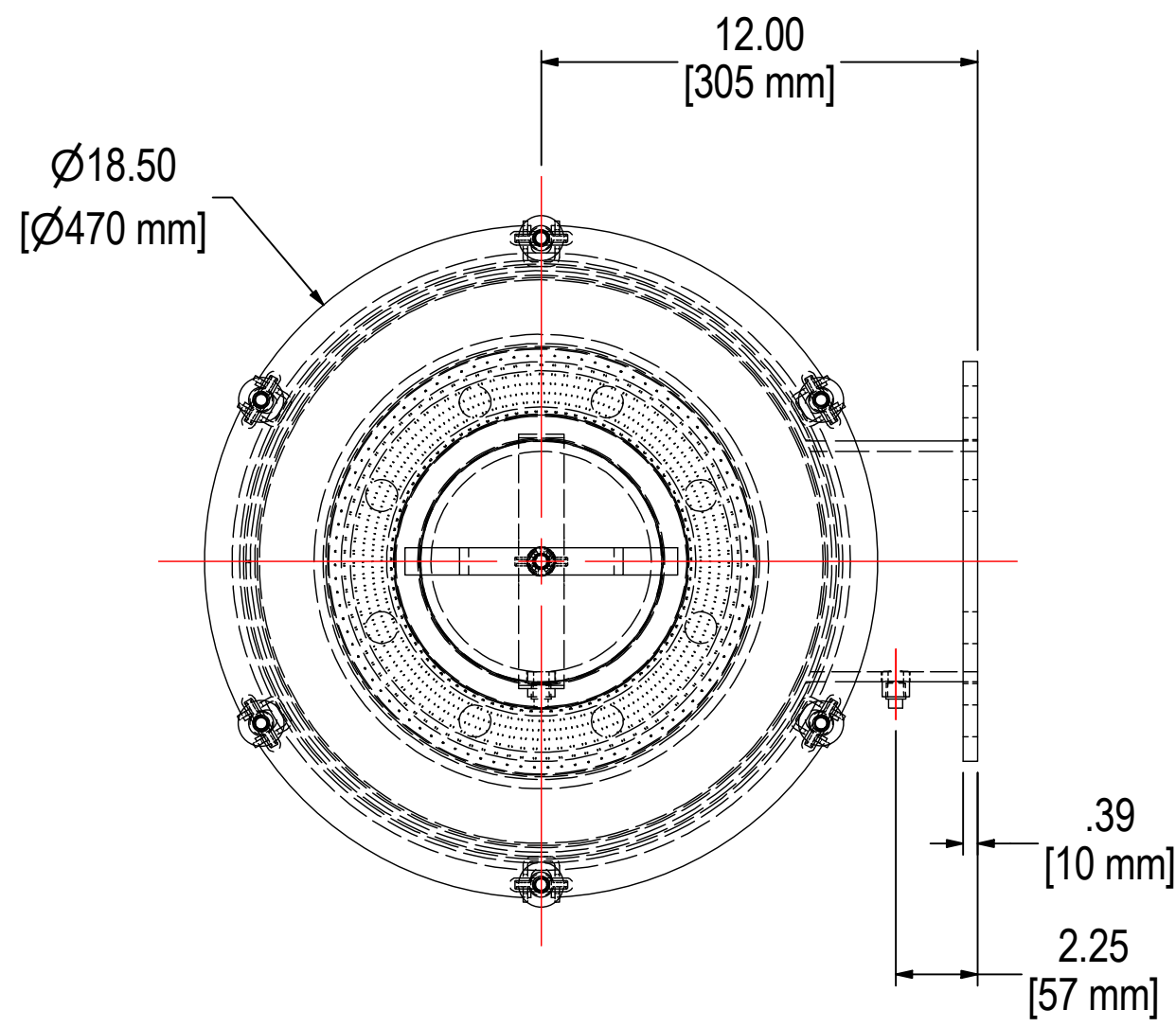

THE INFORMATION CONTAINED HEREIN IS CONFIDENTIAL AND THE PROPERTY OF SOLBERG MANUFACTURING INC. AND IT IS FURNISHED TO YOU WITH THE EXPRESS UNDERSTANDING THAT IT WILL NOT BE REPRODUCED, COPIED IN ANY MANNER, LOANED OR OTHERWISE TRANSFERRED TO OTHERS ENTIRELY OR IN PART, NOR USED FOR ANY PURPOSE OTHER THAN FOR WHICH IT WAS FURNISHED. IT WILL BE RETURNED UPON REQUEST TO SOLBERG MANUFACTURING INC. THE ABOVE RESTRICTION IS IN ADDITION TO, AND DOES NOT IN ANY WAY ALTER, ANY OTHER RESTRICTIONS WHICH MAY APPLY TO THE INFORMATION CONTAINED HEREIN.

TOLERANCES
 DIMENSIONS ARE FOR REFERENCE ONLY. ALL DIMENSIONS ARE SUBJECT TO CHANGE UPON PRODUCTION.
 UNLESS OTHERWISE SPECIFIED:
 -DIMENSIONS ARE IN INCHES
 -REF: APPROXIMATE DIMENSIONS, NO TOLERANCES APPLY
 -FINISH: BREAK EDGES TO .005-.020 RADIUS/CHAMFER