

REV	DESCRIPTION	ECN #	CHG BY	DATE	APP'D
A	UPDATED PART NUMBER, WAS CSL0001306	14224	JSR	08/09/18	TAS
B	REMOVED BAFFLE, MODEL NUMBER WAS CSL-2541-400	14835	NAD	11/02/18	EZR

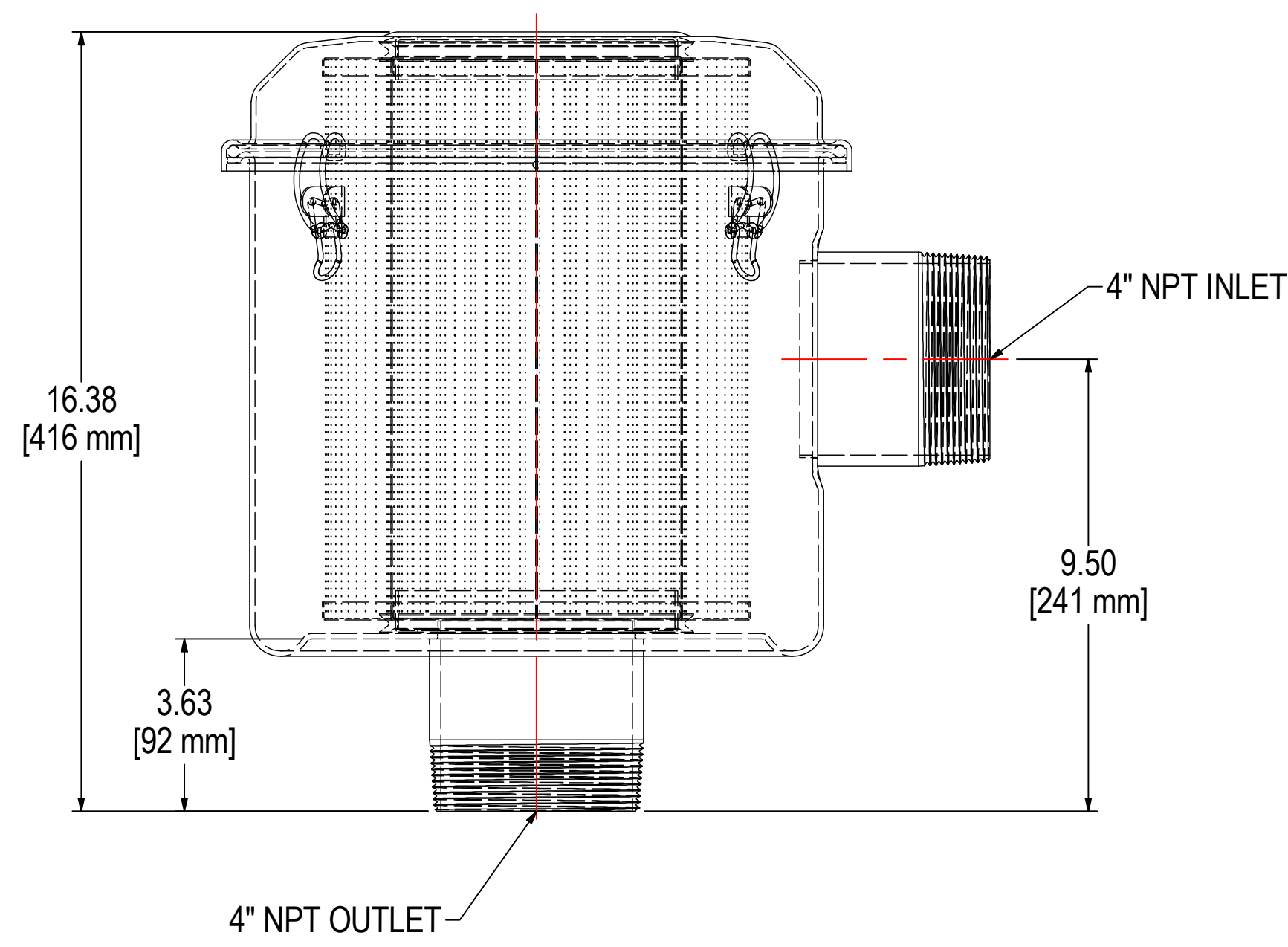
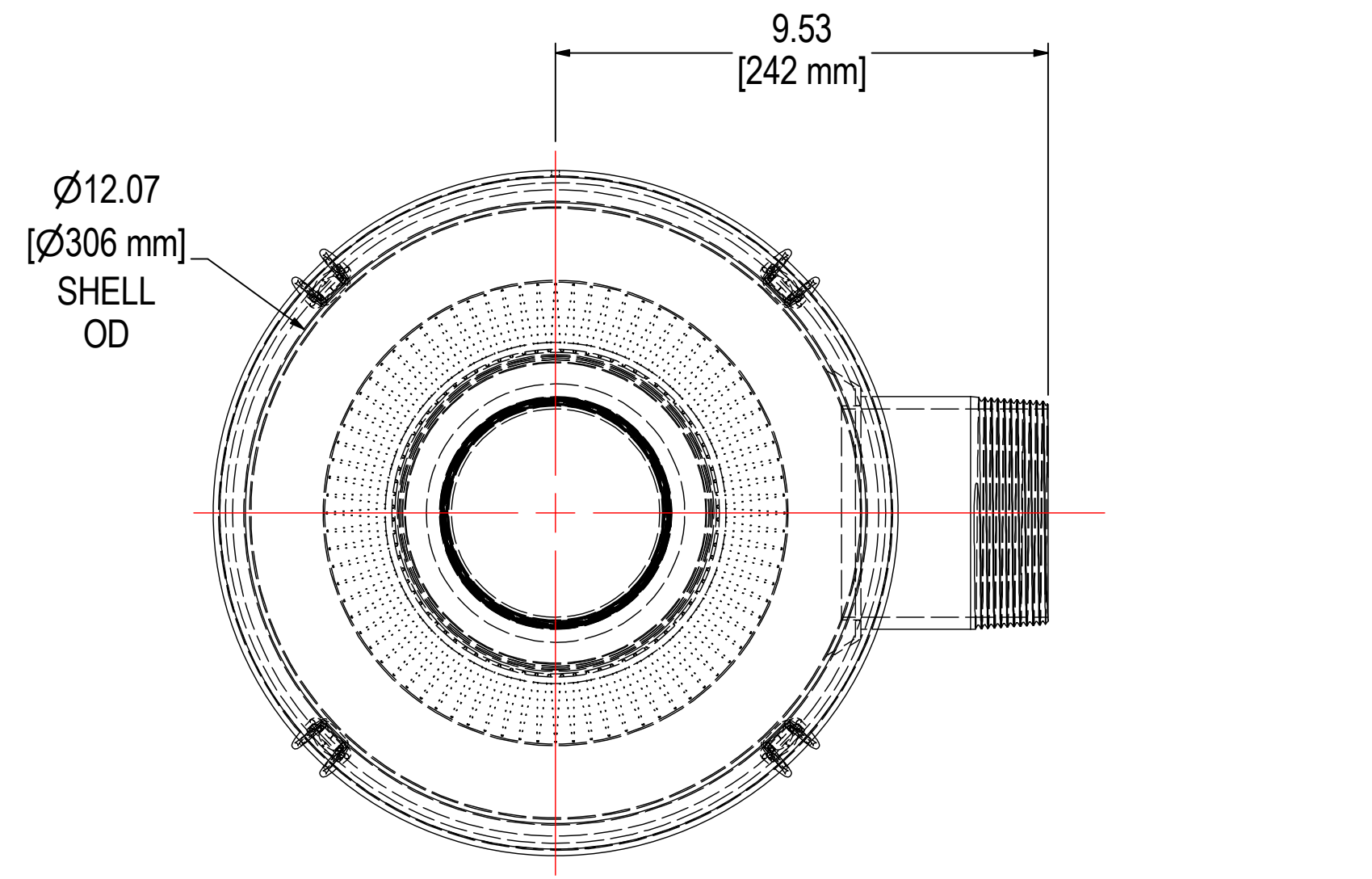

ELEMENT SPECS		
PART NUMBER	2541	
MATERIAL	Polyester	
FLOW RATE	800 CFM	1360 m <sup>3</sup> /hr
SURFACE AREA	15.1 ft <sup>2</sup>	1.4 m <sup>2</sup>
I.D.	6.00"	152mm
O.D.	9.00"	229mm
HEIGHT	11.81"	300mm

MODEL #: CSL-2541-400B	MATERIAL: CARBON STEEL	FINISH: BLACK POWDER	SHEET: 1 OF 1
MODEL NUMBER: CSL-2541-400B	DESCRIPTION: CSL-2541-400B, DOMED TOP, 4" PIPE W/ SHOULDER, BLACK		
PROJECT:	DRAWN BY: JSR DATE: 5/31/2018	APPROVED BY: MJC DATE: 5/31/2018	REV: B

**SOLBERG**  
Filtration • Separation • Silencing  
630.773.1363 • www.solbergmfg.com

THE INFORMATION CONTAINED HEREIN IS CONFIDENTIAL AND THE PROPERTY OF SOLBERG MANUFACTURING INC. AND IT IS FURNISHED TO YOU WITH THE EXPRESS UNDERSTANDING THAT IT WILL NOT BE REPRODUCED, COPIED IN ANY MANNER, LOANED OR OTHERWISE TRANSFERRED TO OTHERS ENTIRELY OR IN PART, NOR USED FOR ANY PURPOSE OTHER THAN FOR WHICH IT WAS FURNISHED. IT WILL BE RETURNED UPON REQUEST TO SOLBERG MANUFACTURING INC. THE ABOVE RESTRICTION IS IN ADDITION TO, AND DOES NOT IN ANY WAY ALTER, ANY OTHER RESTRICTIONS WHICH MAY APPLY TO THE INFORMATION CONTAINED HEREIN.

**TOLERANCES**  
DIMENSIONS ARE FOR REFERENCE ONLY. ALL DIMENSIONS ARE SUBJECT TO CHANGE UPON PRODUCTION.  
UNLESS OTHERWISE SPECIFIED:  
-DIMENSIONS ARE IN INCHES  
-REF: APPROXIMATE DIMENSIONS, NO TOLERANCES APPLY  
-FINISH: BREAK EDGES TO .005-.020 RADIUS/CHAMFER