

All materials supplied are in compliance with the requirements of the List of Prohibited Substances.
 CONFIDENTIAL: The content is property of Atlas Copco LLC and shall not be used or reproduced without the permission of Atlas Copco. This document is intended for communication with other persons or companies.

CRS/CRP-80V

Ed	Position	Description	Date	Intr./Appd.
00		DRAWING RELEASED	04/22	BW

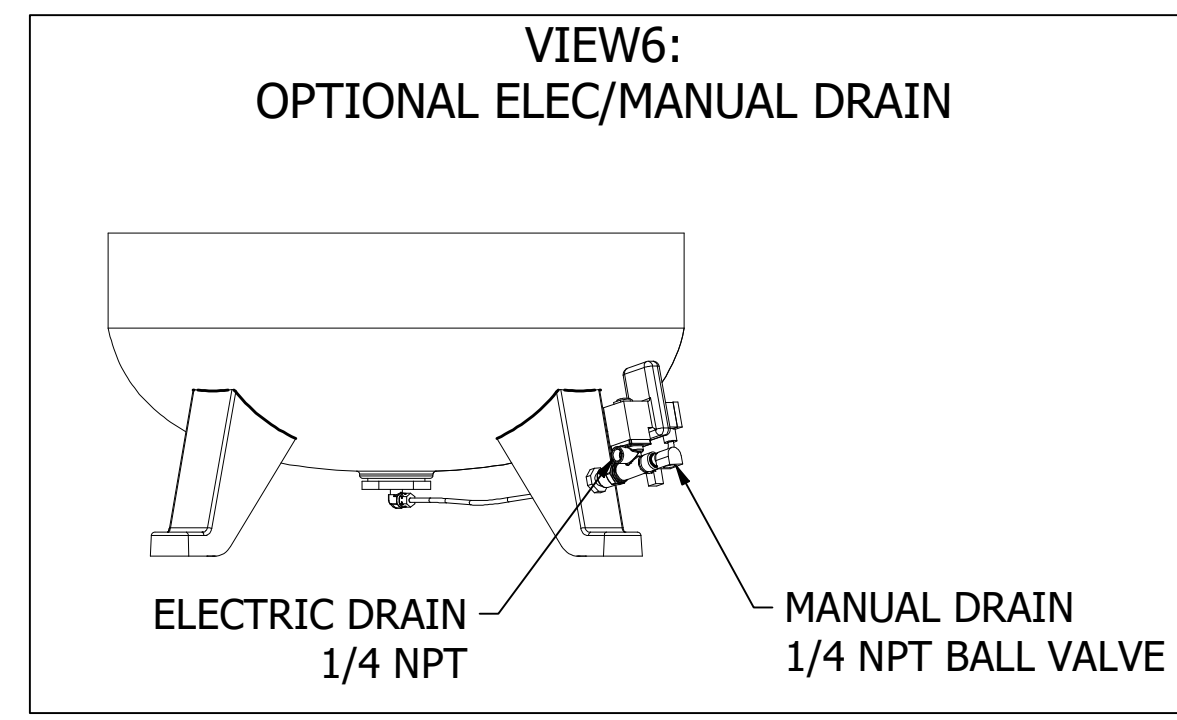
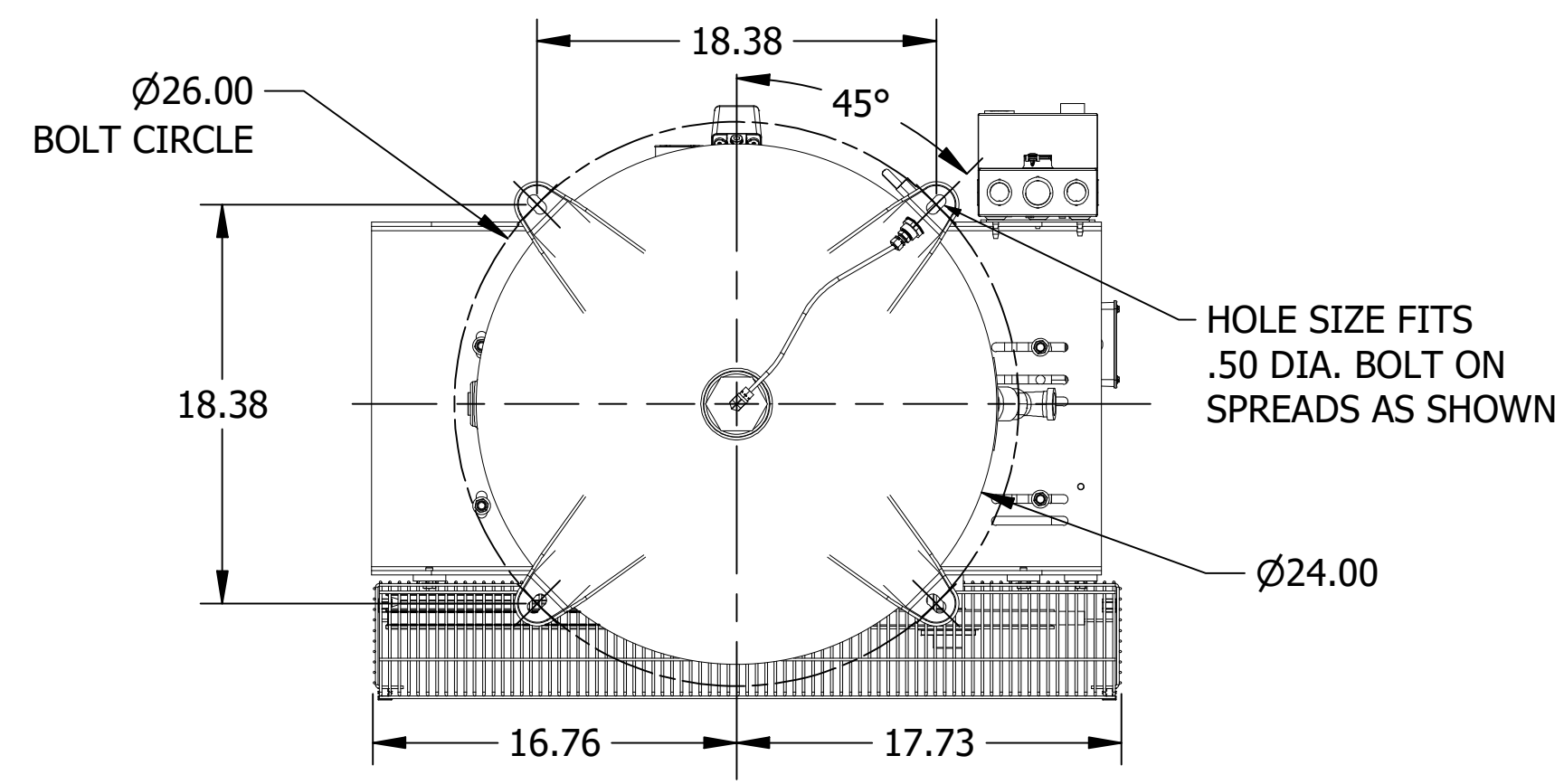
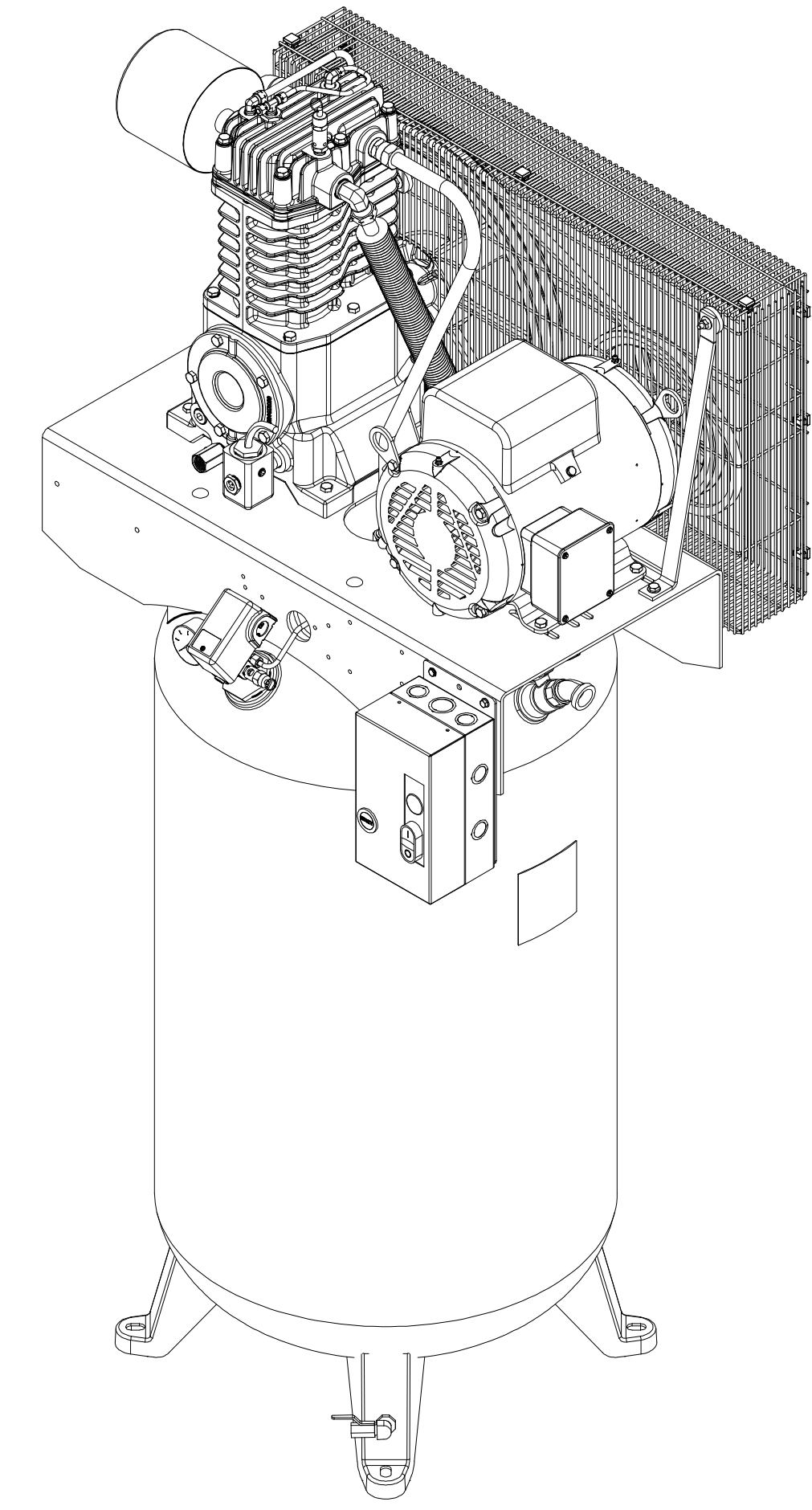
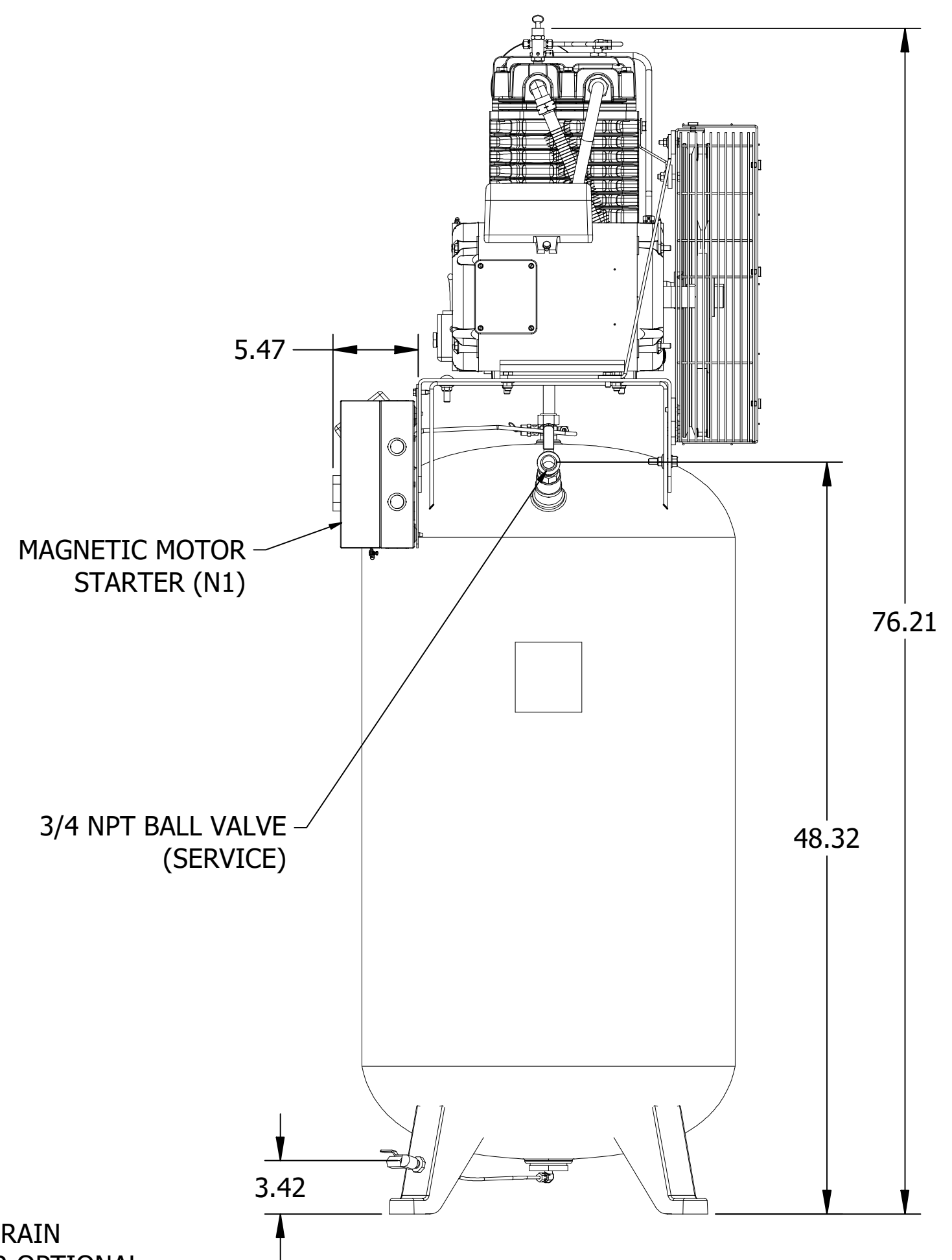
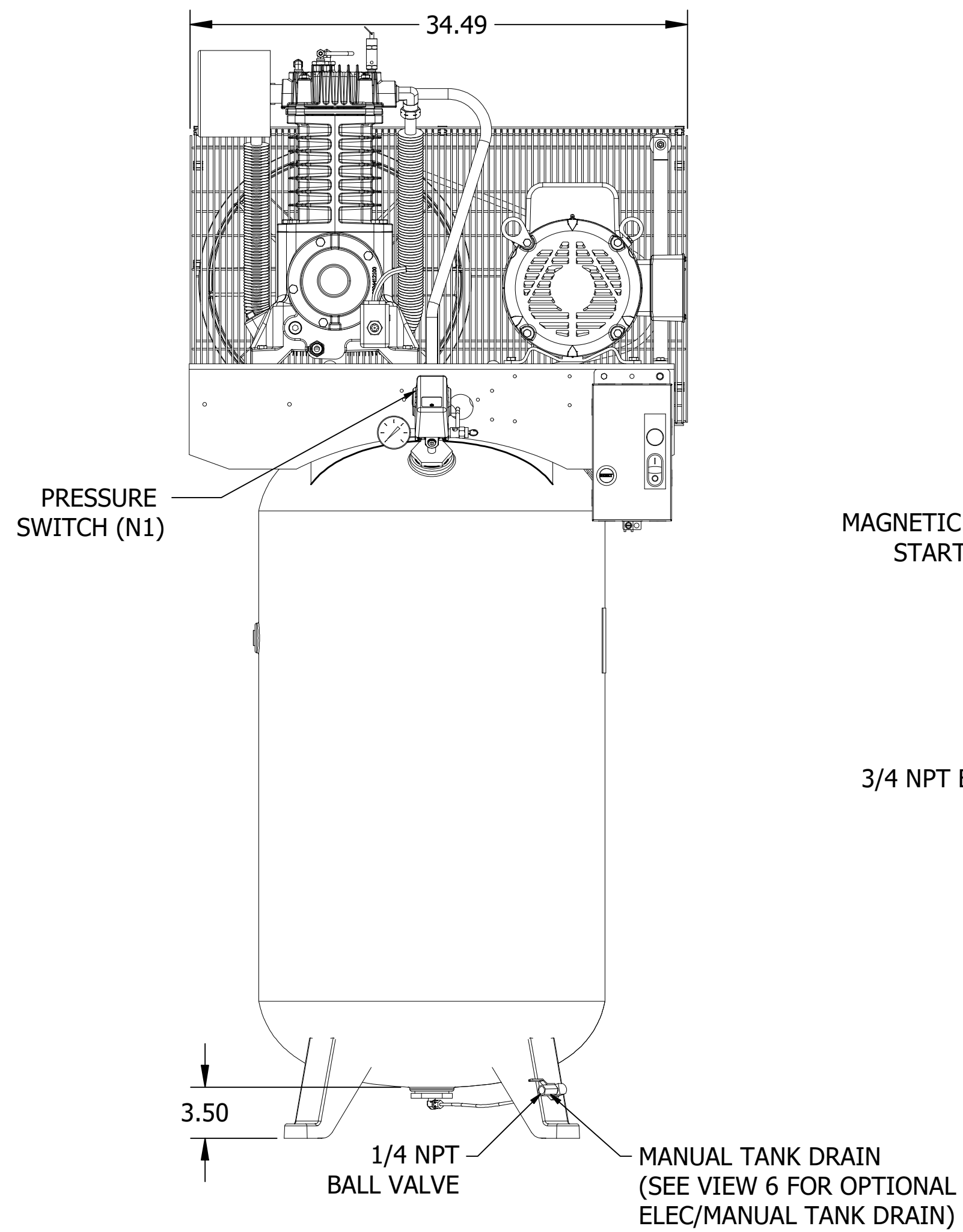
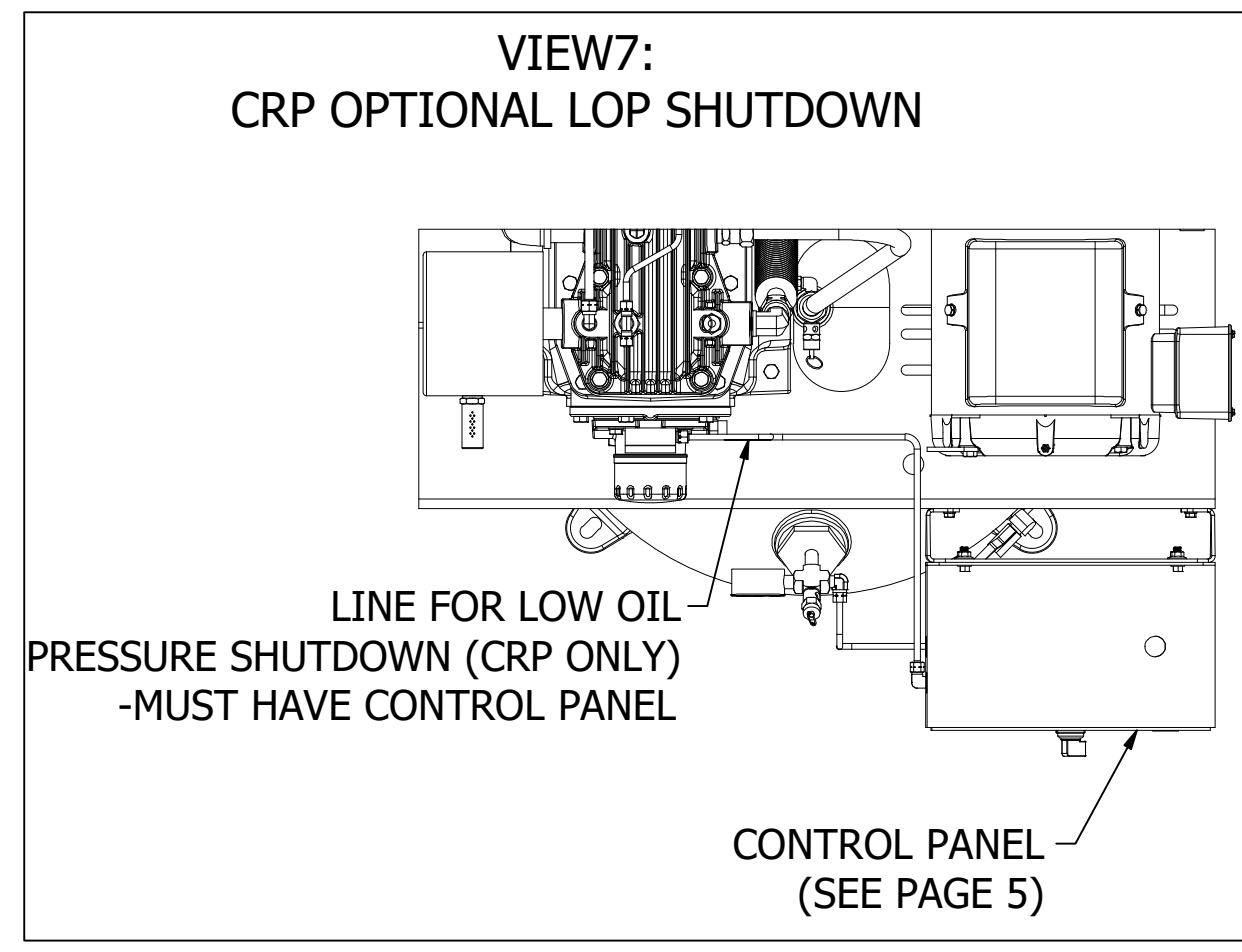
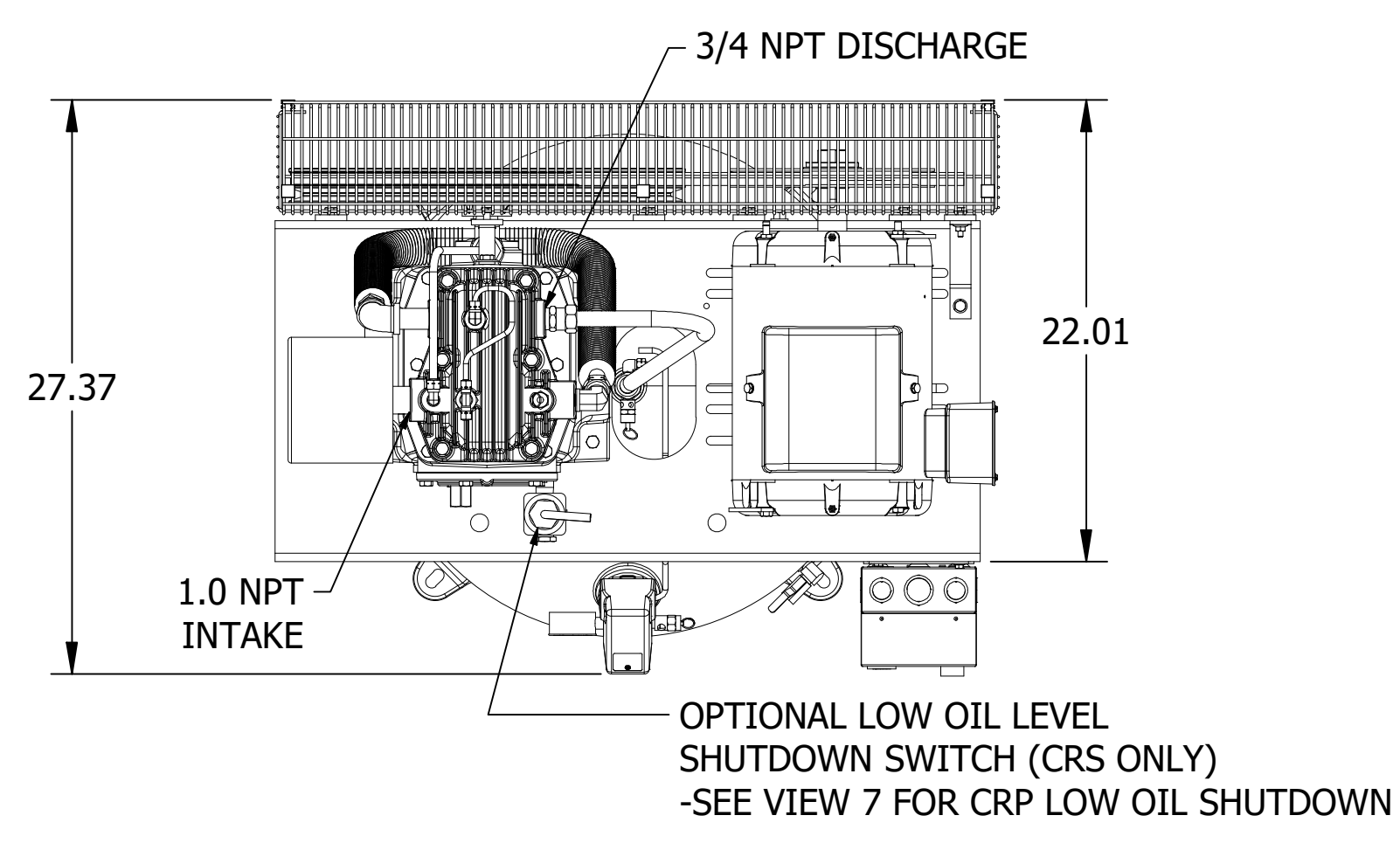

- NOTES:**
- 1) ALL DIMENSIONS GIVEN IN INCHES.
 - 2) ALLOW FOR A MINIMUM OF 12 INCHES ON ALL SIDES FOR SERVICE AND COOLING.
 - 3) CRS-1 IS A SPLASH LUBRICATED COMPRESSOR.
 - 4) CRP-1 IS A PRESSURE LUBRICATED COMPRESSOR.
 - 5) AVAILABLE WITH 3, 5, OR 7.5 HORSEPOWER MOTOR.
 - 6) THIS DRAWING IS INTENDED TO ILLUSTRATE MULTIPLE UNITS SHARING THE SAME OVERALL PACKAGE DIMENSIONS. ACTUAL UNIT MAY APPEAR DIFFERENT DEPENDING ON PUMP, MOTOR HP, AND OPTIONS SELECTED.
 - 7) SEE ALL PAGES IN THIS DOCUMENT FOR REPRESENTATION OF CONFIGURATIONS THAT PROVIDE DIFFERENT OVERALL DIMENSIONS.

Name		DWG.DIM.CRS/CRP-1,80V		Confidentiality Class											
Material		Not Applicable		1102K Internal											
Finish		Not Applicable		INV											
Scale	1:8	Family		Similar to											
Drawn by	UTYBALKER	Make From		Replaces											
Version Drwg		Blank wt		Designation											
Des checked		Prod checked		Approved											
Parent 3D model	Ed. Version 3D	Approved	Internal	Date	7/04/2022										
<table border="1"> <tr> <td>STATUS</td> <td>Version Drwg</td> <td>Blank wt</td> <td>lb</td> <td>Fini wt.</td> <td>0.0</td> <td>lb</td> <td>Designation</td> <td>Sheet</td> <td>1 / 5</td> </tr> </table>					STATUS	Version Drwg	Blank wt	lb	Fini wt.	0.0	lb	Designation	Sheet	1 / 5	2022035412 2022036153
STATUS	Version Drwg	Blank wt	lb	Fini wt.	0.0	lb	Designation	Sheet	1 / 5						

OPTIONAL AFTERCOOLER

Ed	Posi- ion	Description	Date	Intr./Appr.
00		DRAWING RELEASED	04/22	BW

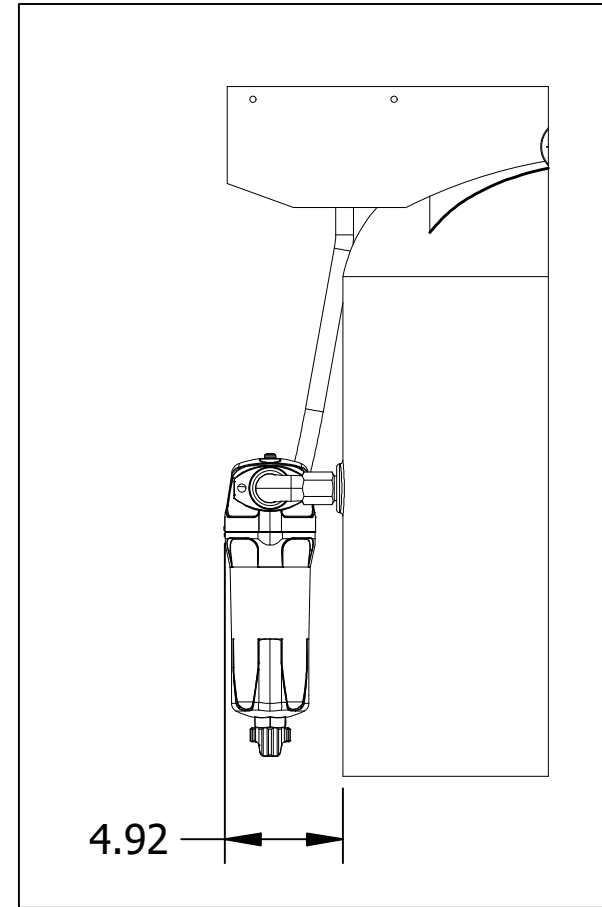
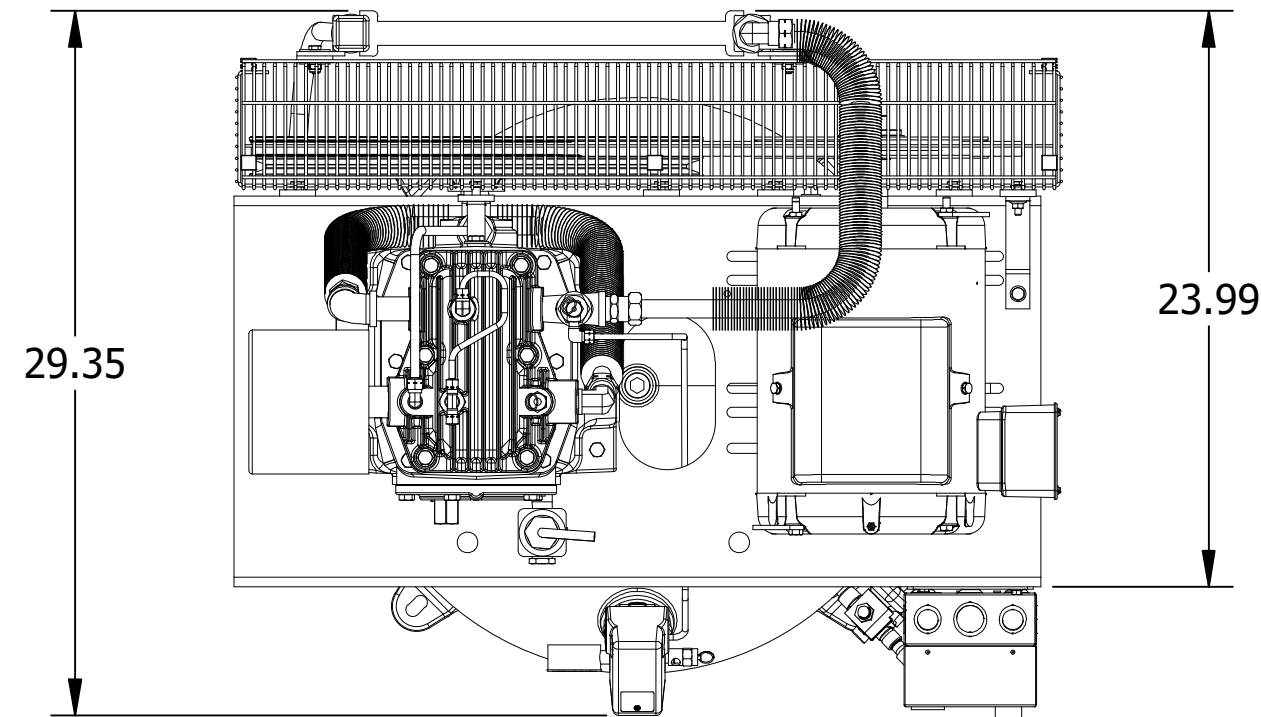

OPTIONAL
MOISTURE TRAP

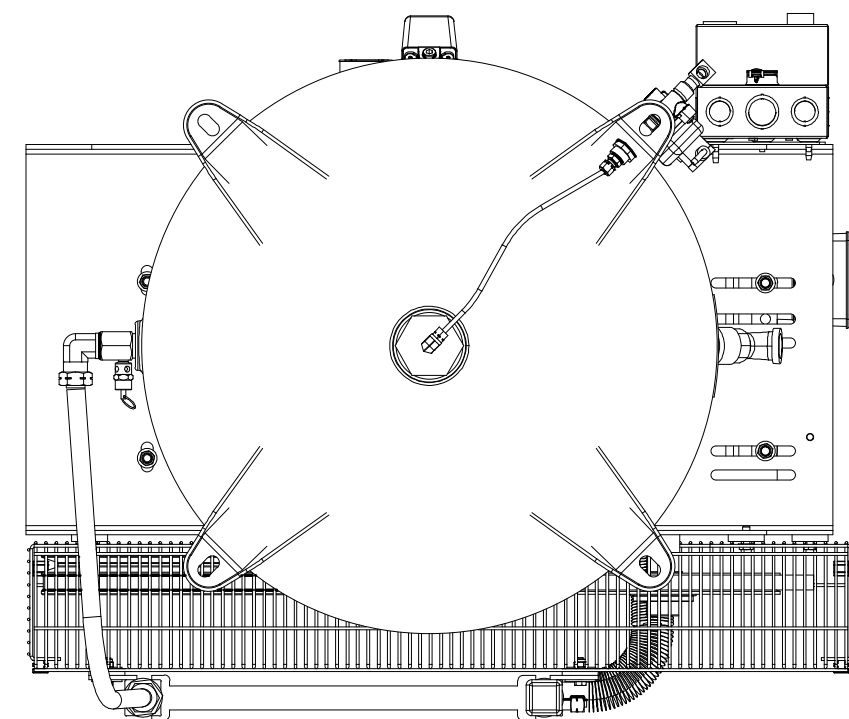
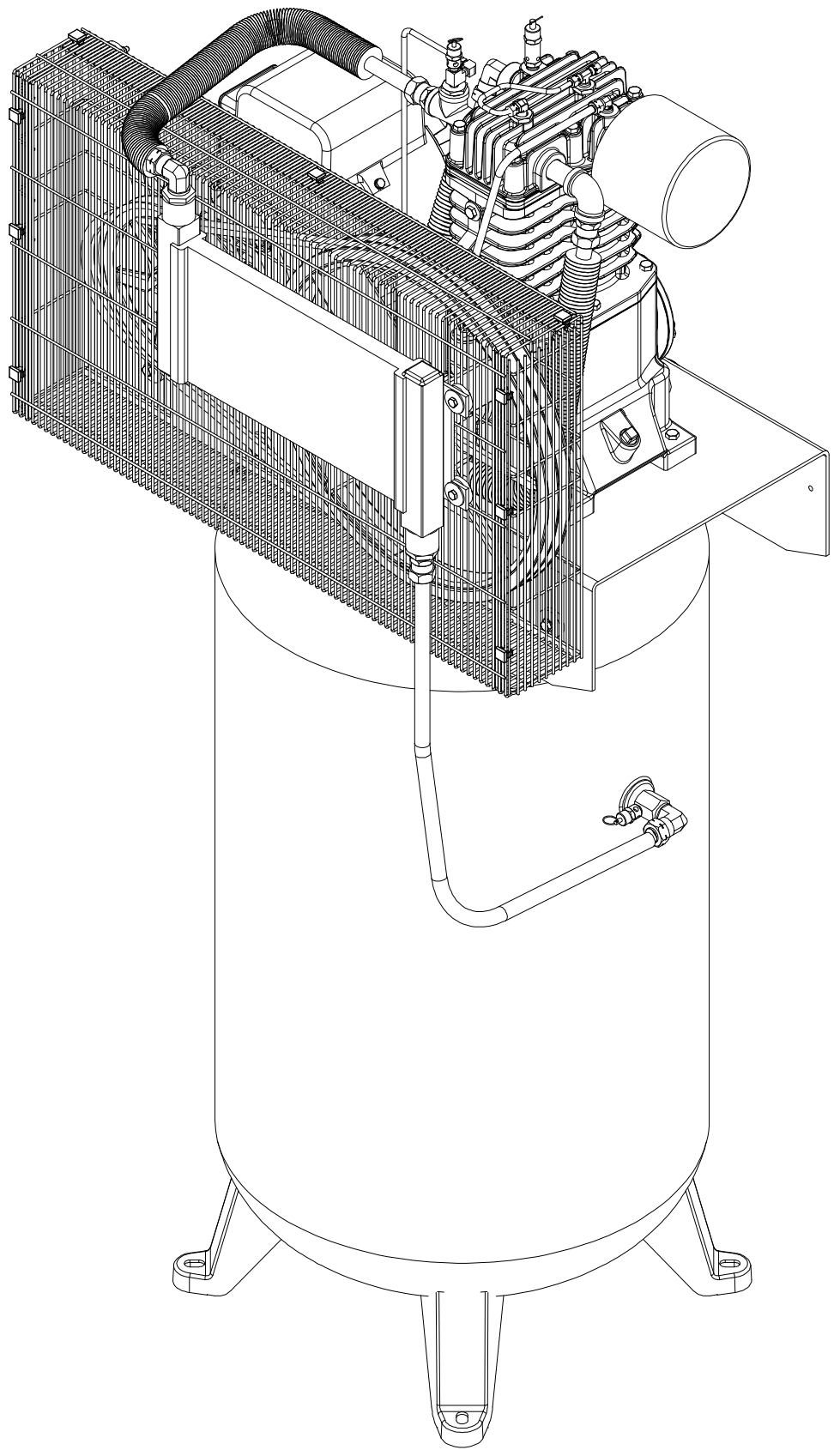
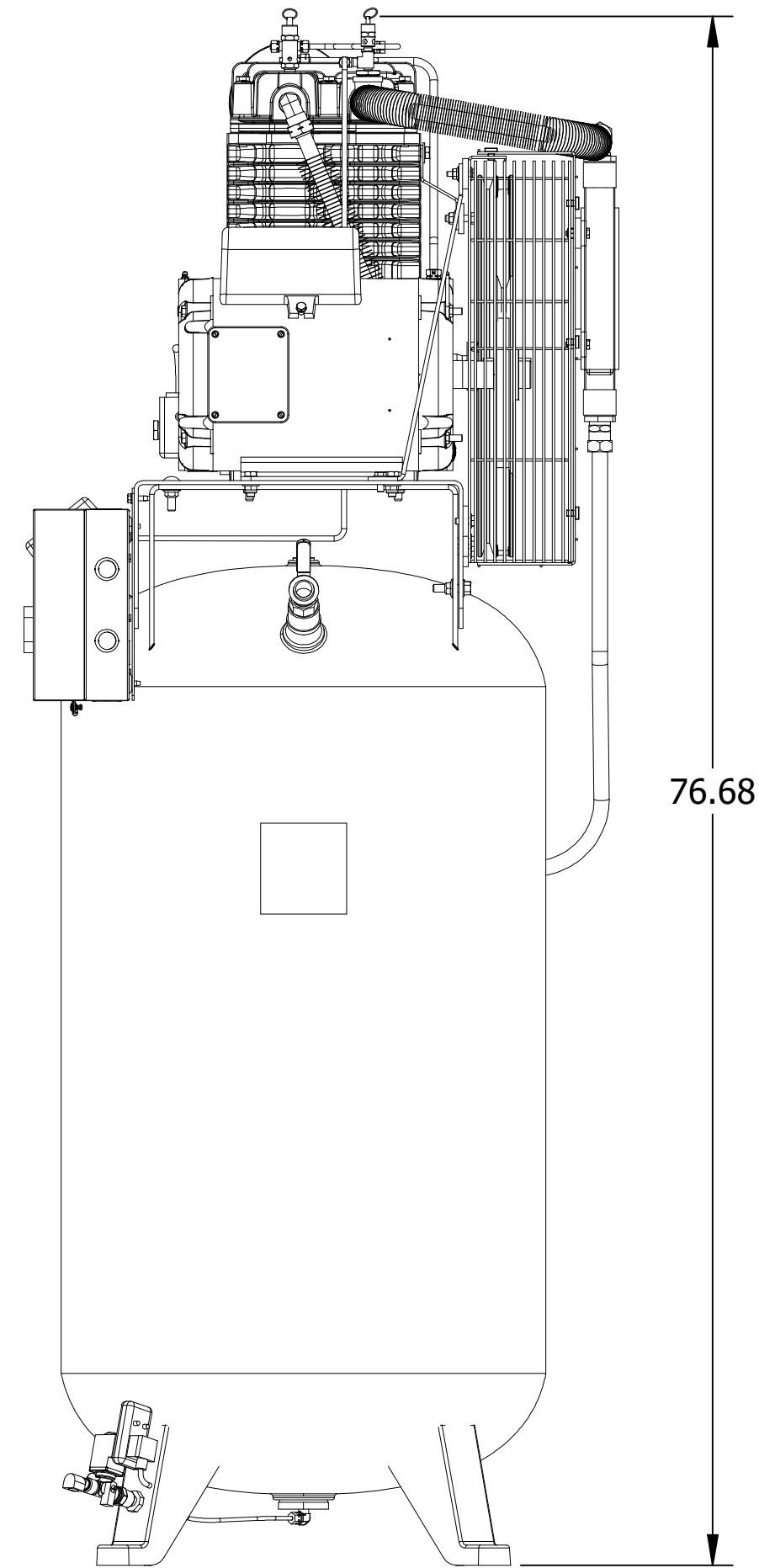
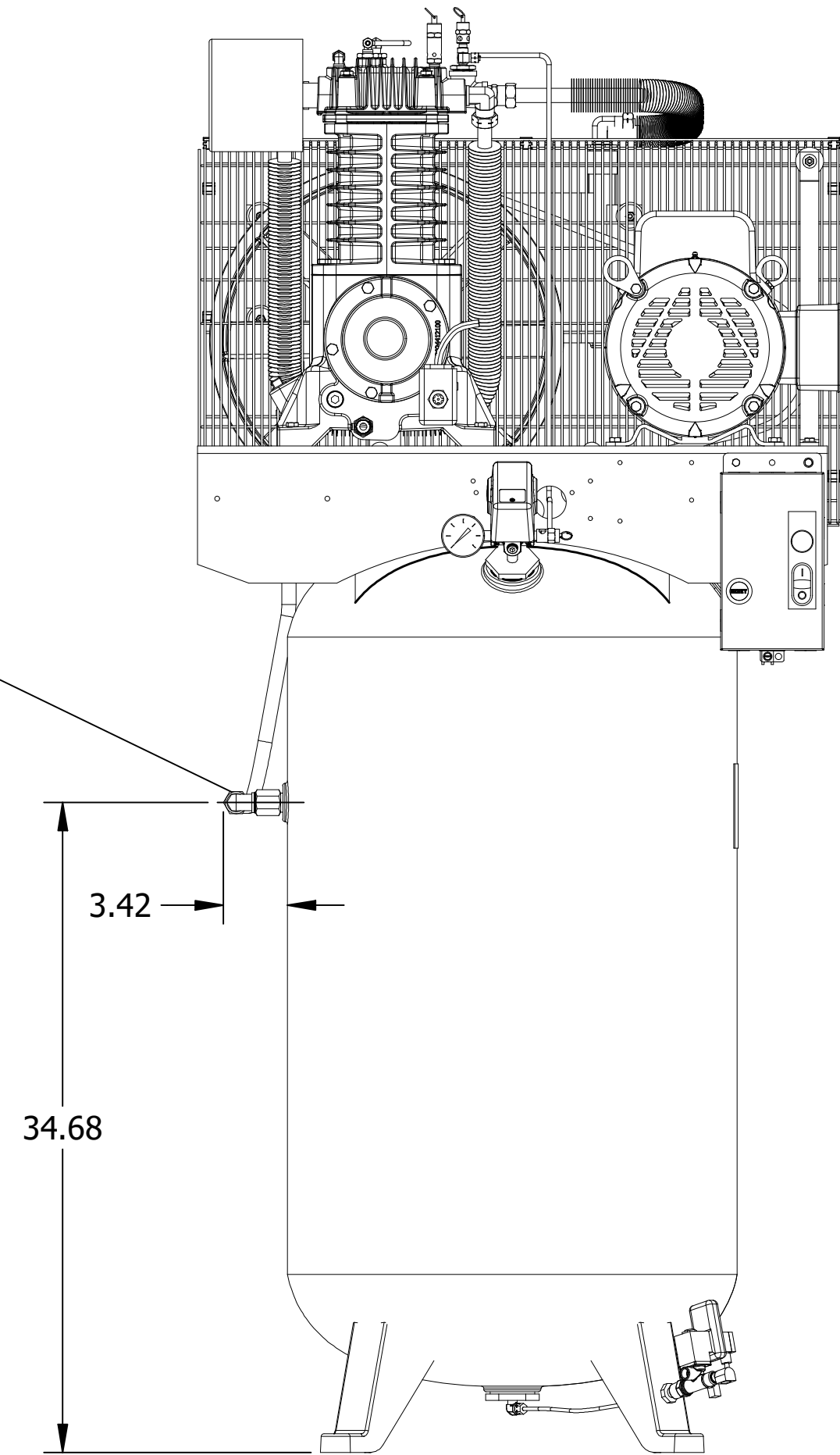

Name		DWG.DIM.CRS/CRP-1,80V			Confidentiality Class acc. to 1102K Internal	
Material		Not Applicable			INV	
Finish		Not Applicable			Drawing owner UTY	
Scale		1:8	Family	D	Similar to	Replaces
Drawn by		UTYBALKER	Make From			
Version Drwg			Blank wt	lb	Fini wt	0.0 lb
STATUS		Des checked.	Prod checked.	Approved.	Date	7/04/2022
Parent 3D model		Ed . Version 3D	Approved Internal			2022036153
						Sheet 2 / 5

CONFIDENTIAL - The content is property of Atlas Copco LLC and shall not be disclosed or used for manufacturing or commercialized by any other person or company.

OPTIONAL PRV (CLIMATE CONTROL ONLY)

Ed	Position	Description	Date	Intr./Appd.
00		DRAWING RELEASED	04/22	BW

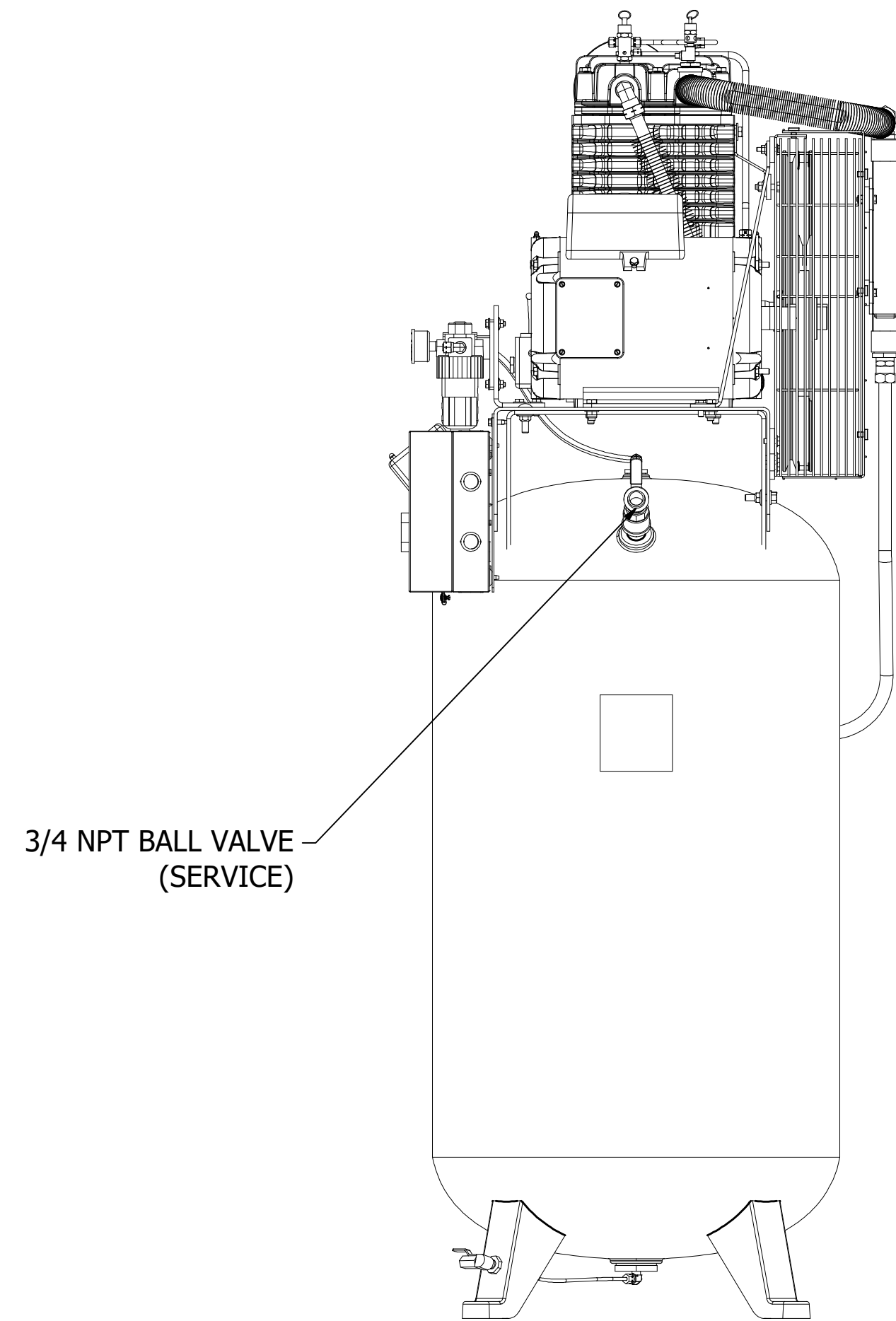
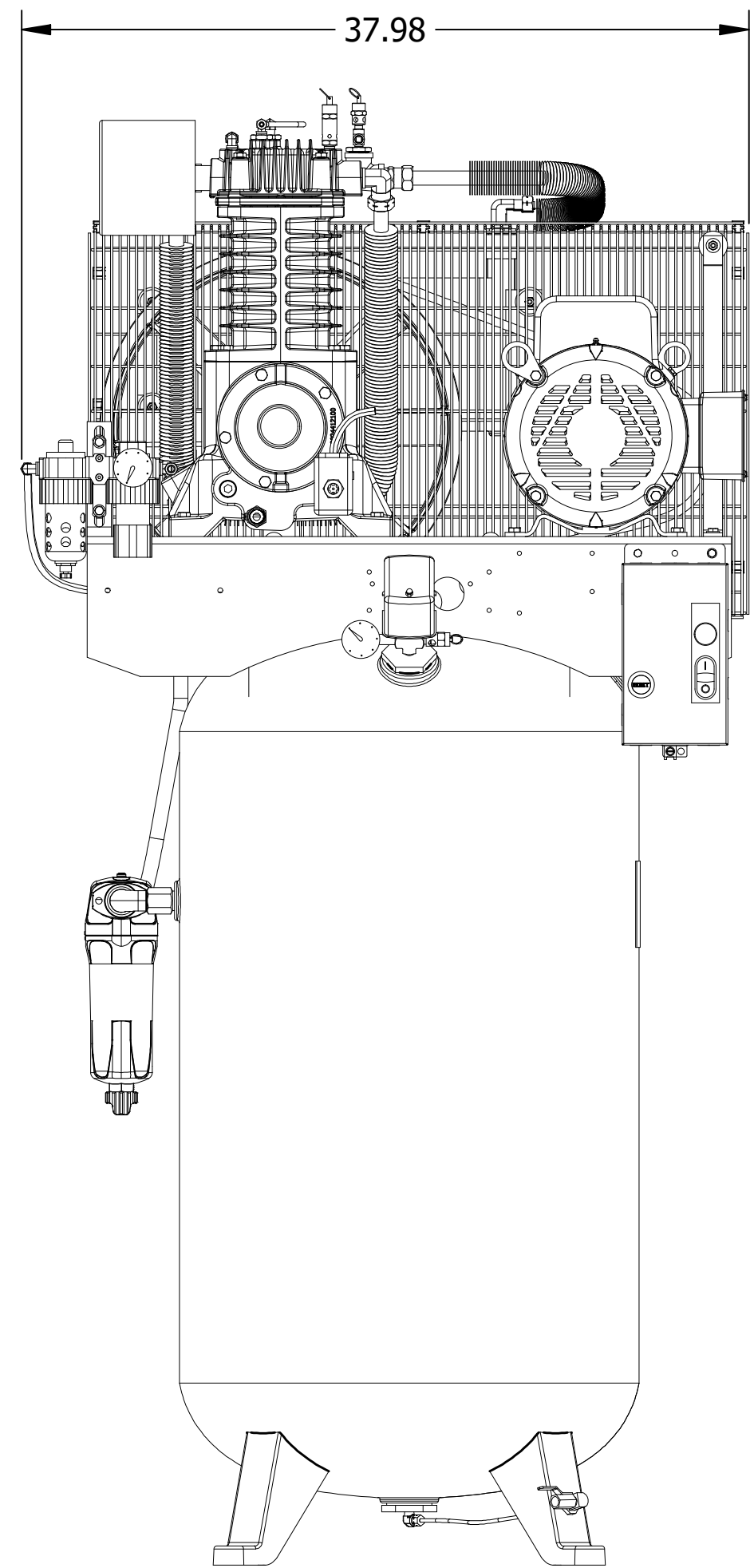
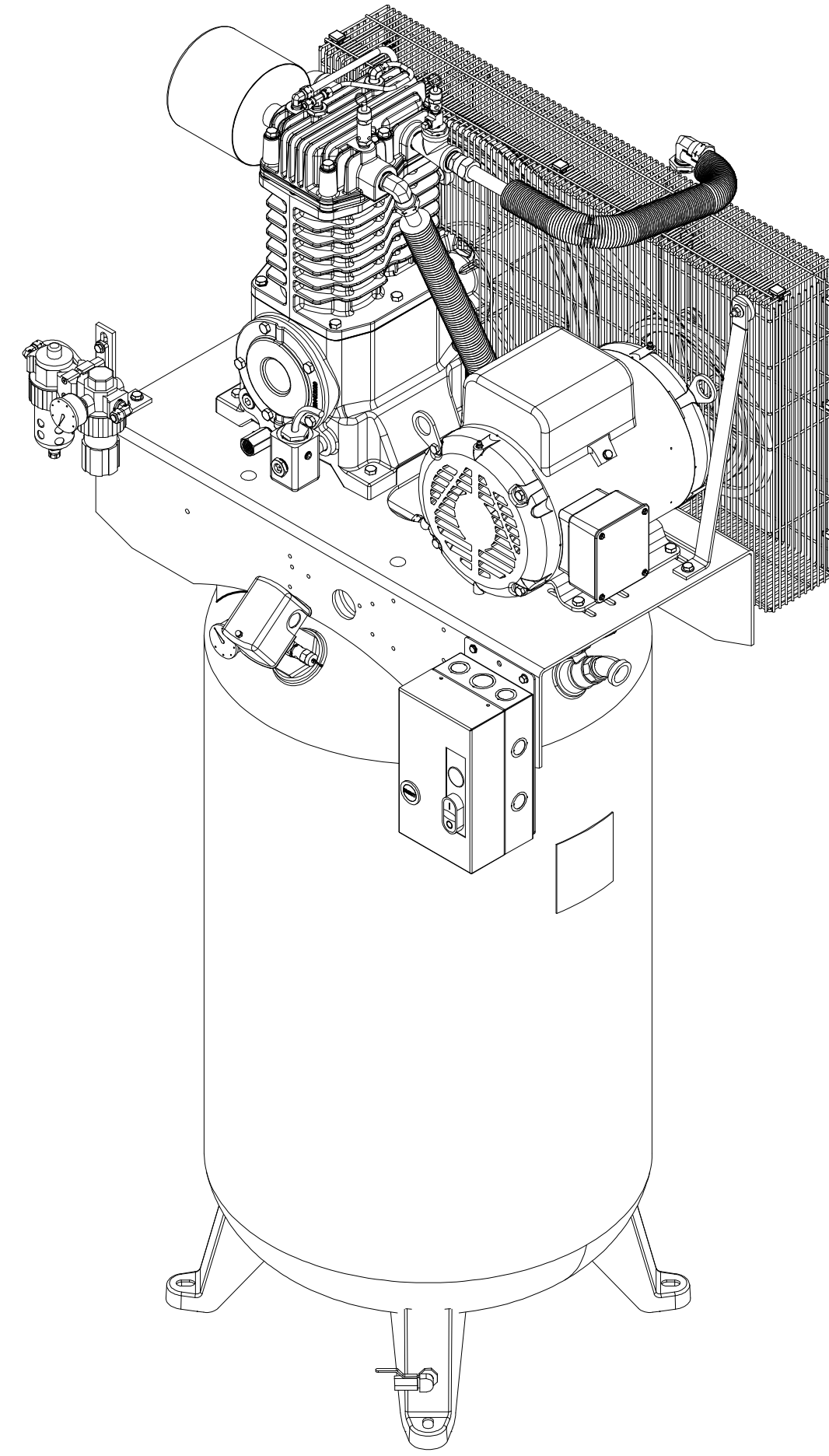
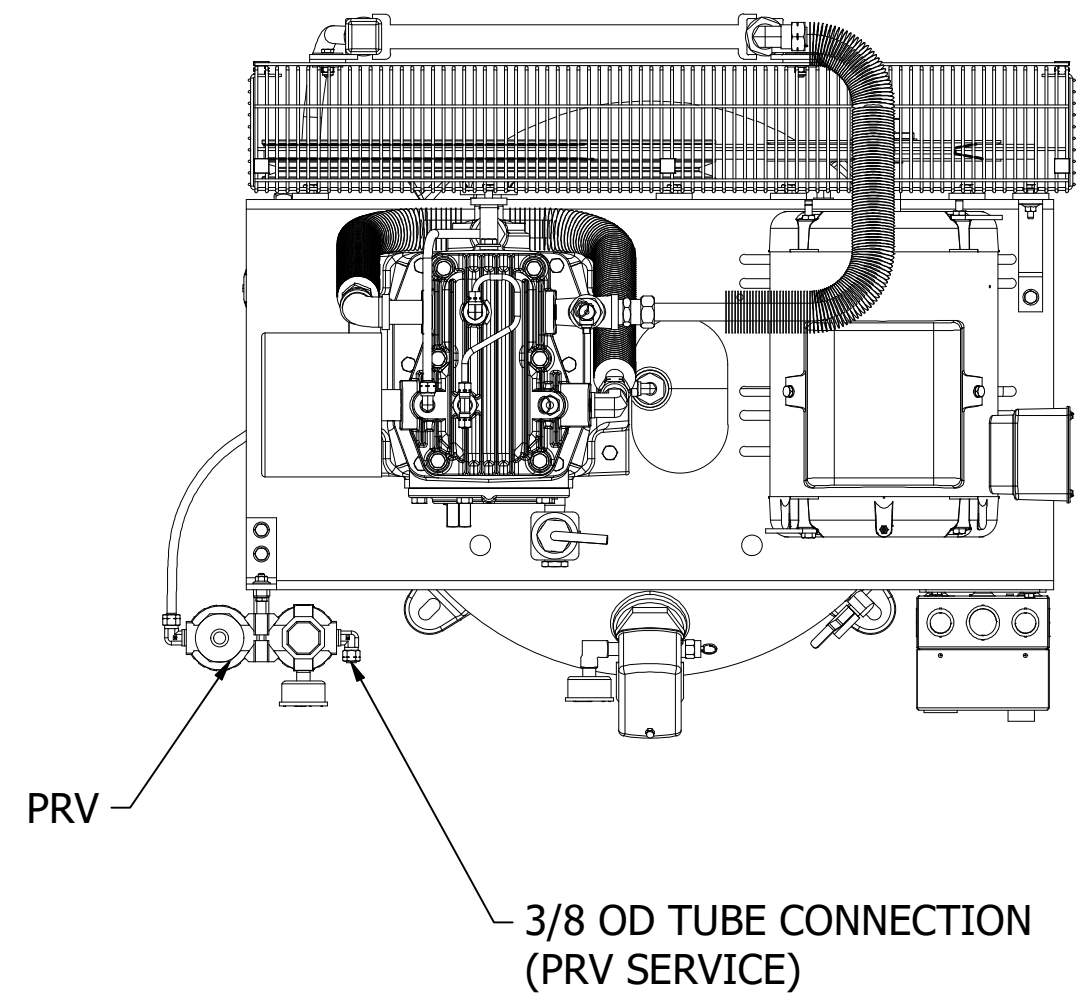

Name		DWG.DIM.CRS/CRP-1,80V			Confidentiality Class acc. to 1102K Internal	
Material		Not Applicable			INV	
Finish		Not Applicable			Drawing owner UTY	
Scale		1:8	Family	D	Similar to	Replaces
Drawn by		UTYBALKER	Make From			
Version Drwg			Blank wt	lb	Fini wt	0.0 lb
STATUS		Des checked.	Prod checked.	Approved.	Date	7/04/2022
Parent 3D model		Ed . Version 3D	Approved Internal			2022036153
						Sheet 3 / 5

CONFIDENTIAL: This document is property of Atlas Copco LLC and shall not be used or reproduced without our permission. All rights reserved.

OPTIONAL N4 MAG STARTER/PRESSURE SWITCH

Ed	Posi- ion	Description	Date	Intr./Appr.
00		DRAWING RELEASED	04/22	BW

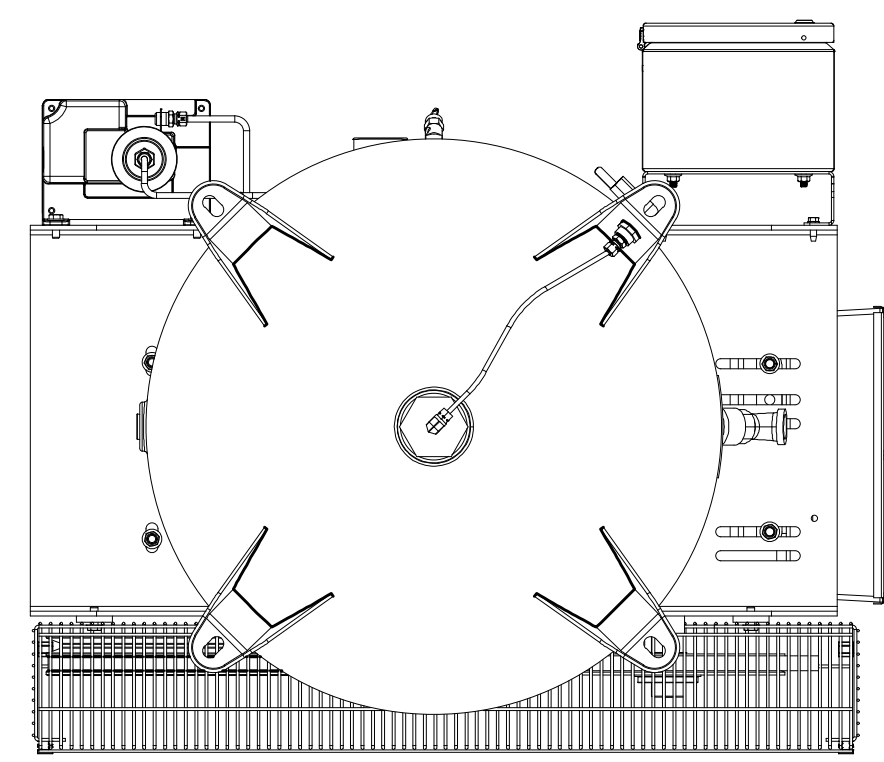
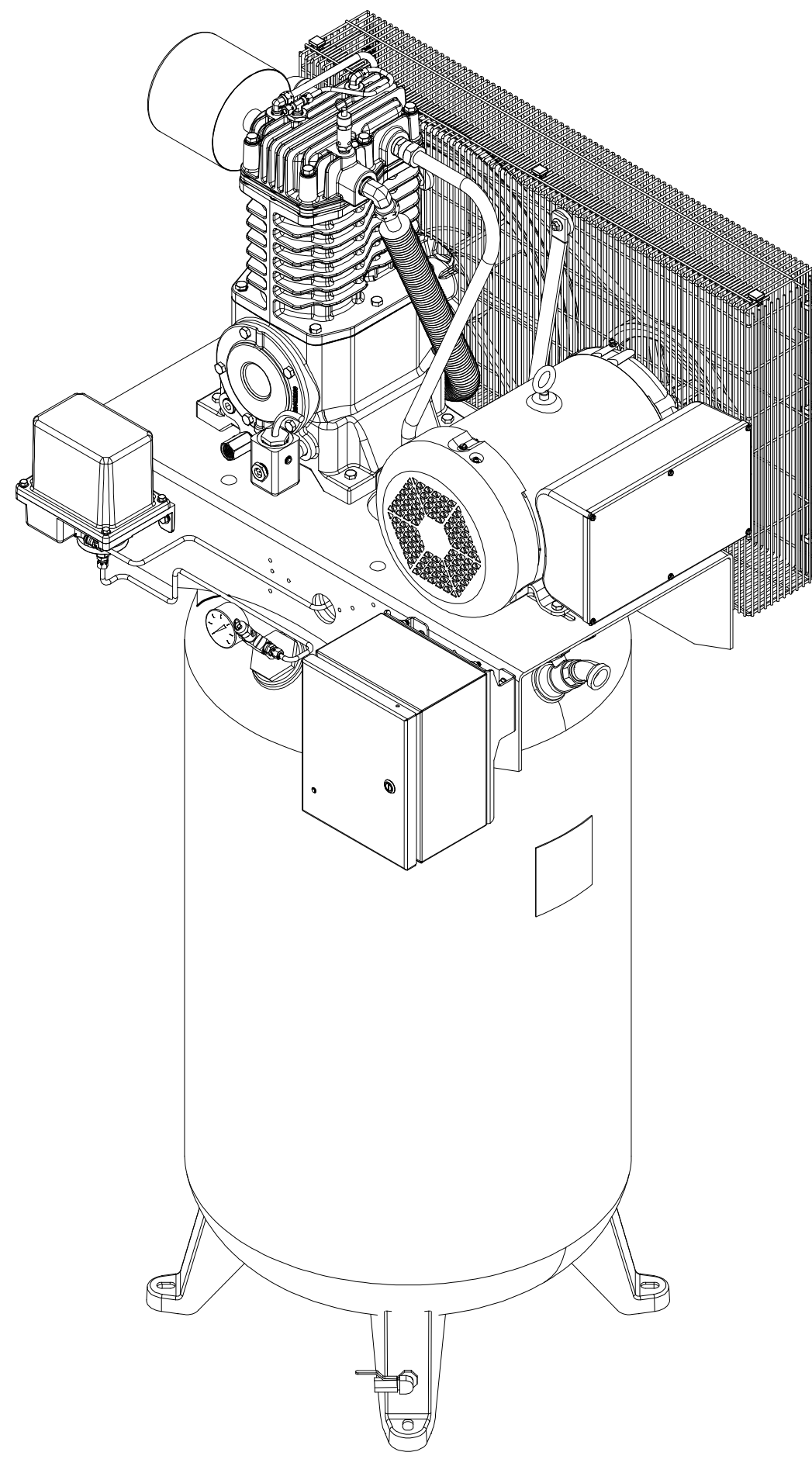
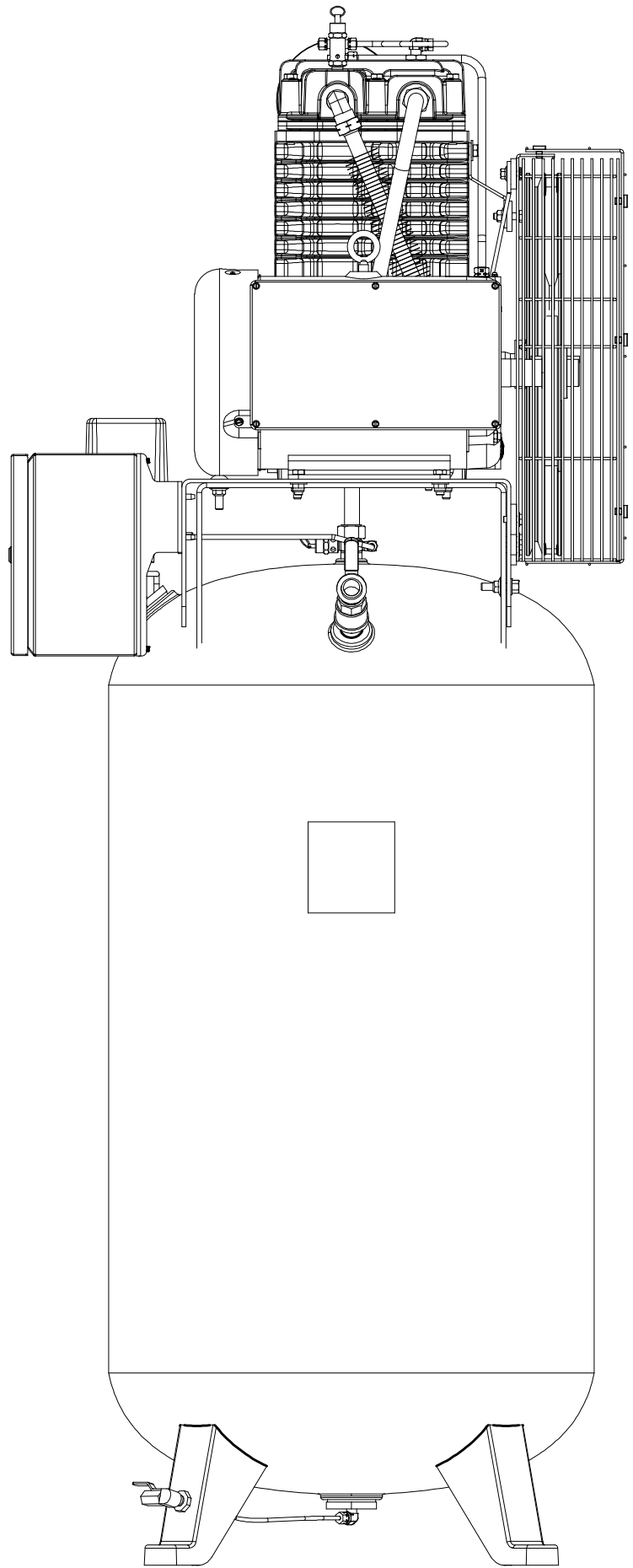
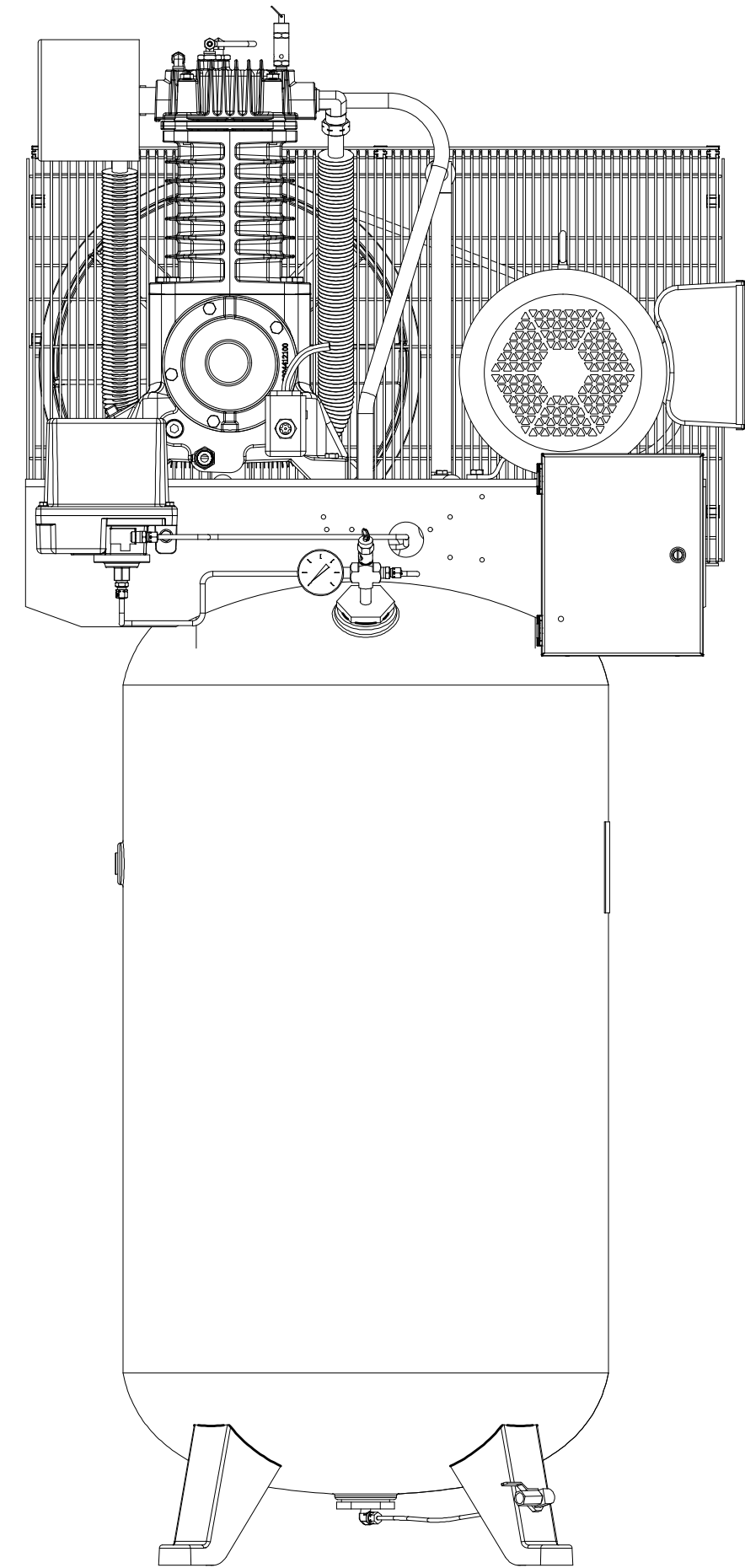
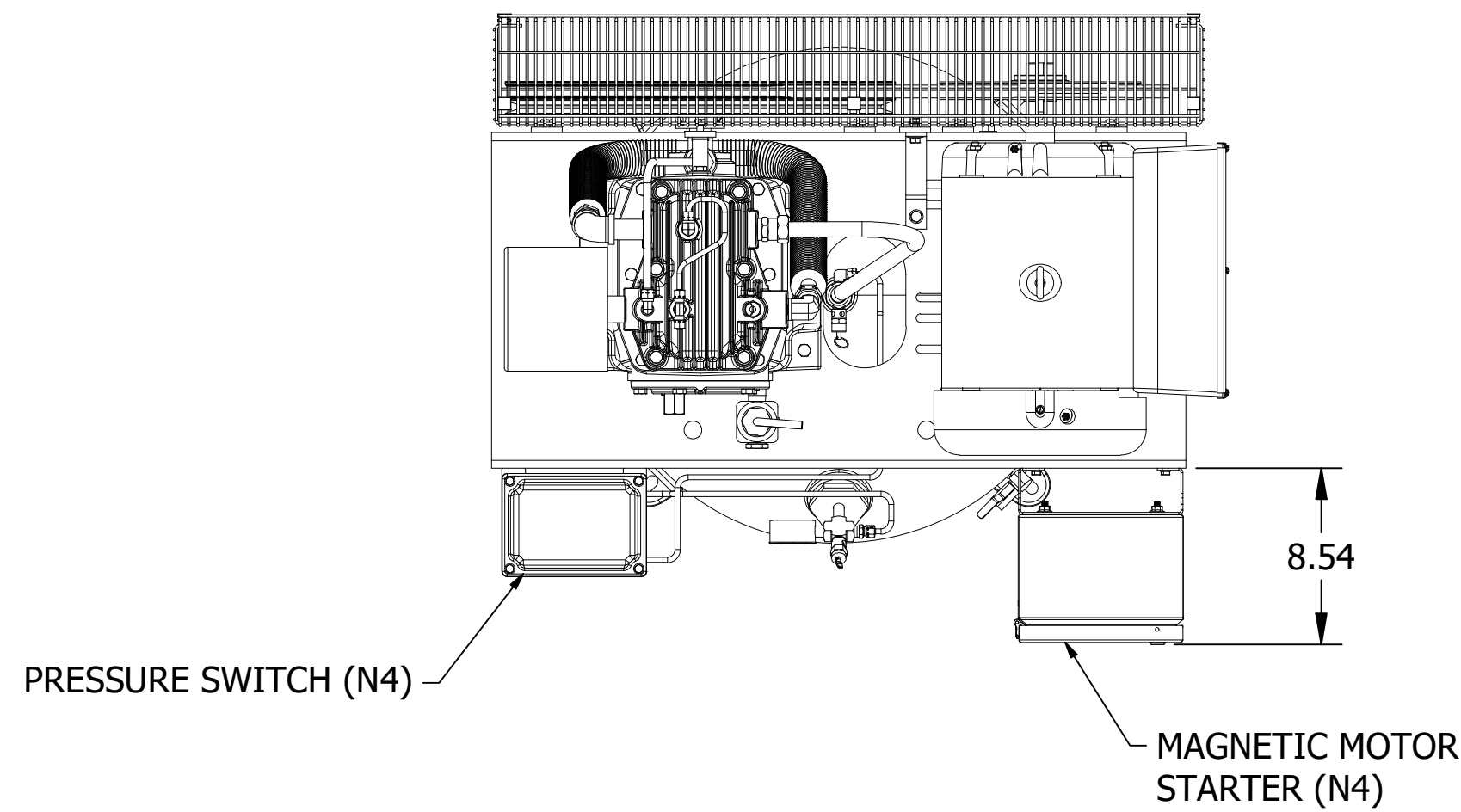

CONFIDENTIAL - The contents of this drawing are the property of Atlas Copco LLC and shall not be disclosed or used for manufacturing or communication to any other person or company.

Name		DWG.DIM.CRS/CRP-1,80V				Confidentiality Class acc. to 1102K Internal	
Material		Not Applicable				INV	
Finish		Not Applicable				Drawing owner UTY	
Scale		1:8		Family		D Similar to	
Drawn by		UTYBALKER		Make From		Replaces	
Version Drwg		Blank wt		Ib		Fini wt	
Des checked.		Prod checked.		Approved.		Date	
Parent 3D model		Ed. Version 3D		Approved Internal		Date 7/04/2022	
2022035412						0.0 lb	
						Designation	
						Sheet 4 / 5	
						2022036153	

OPTIONAL SIMPLEX CONTROL PANEL

Ed	Position	Description	Date	Intr./Appd.
00		DRAWING RELEASED	04/22	BW

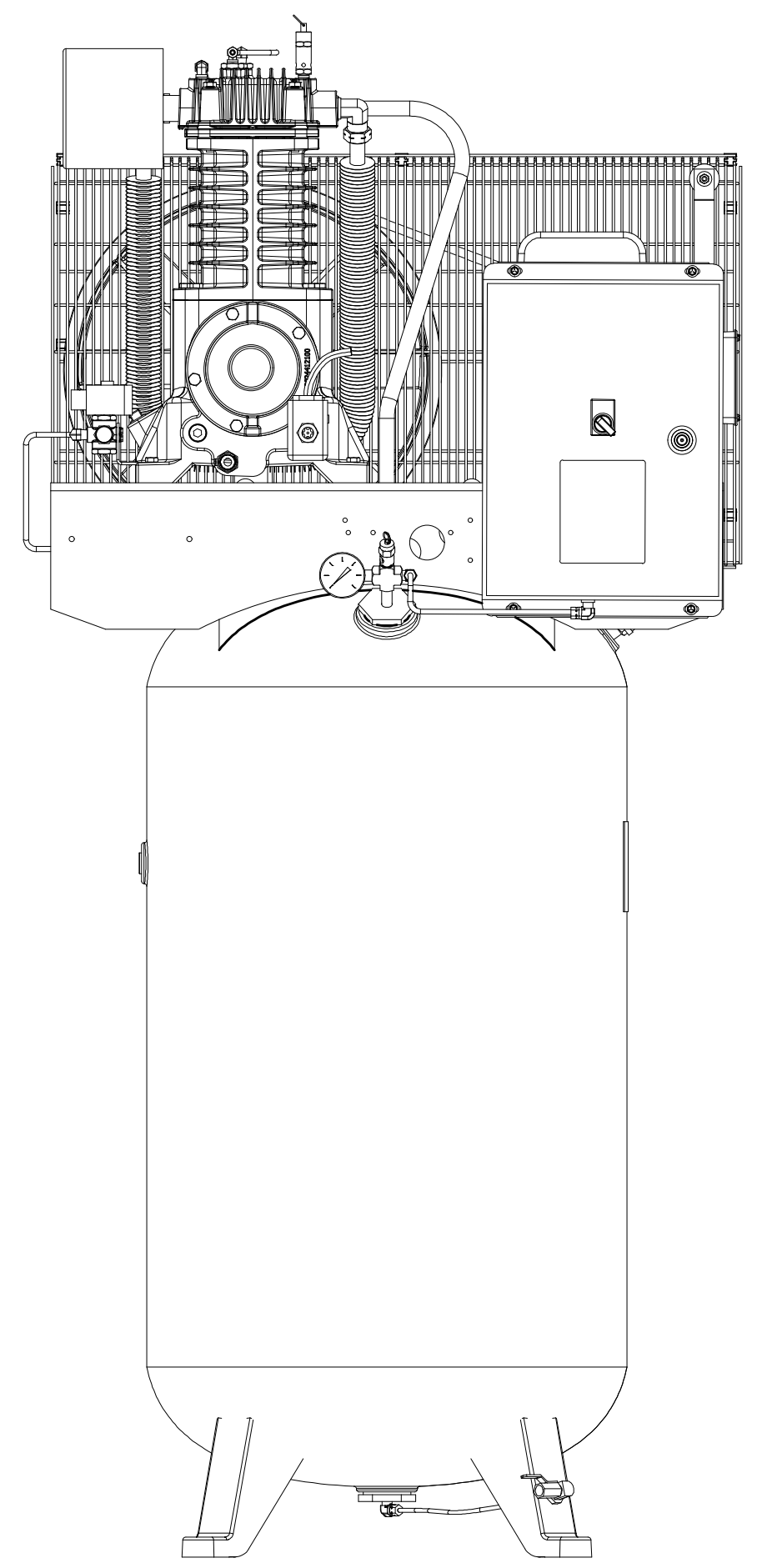
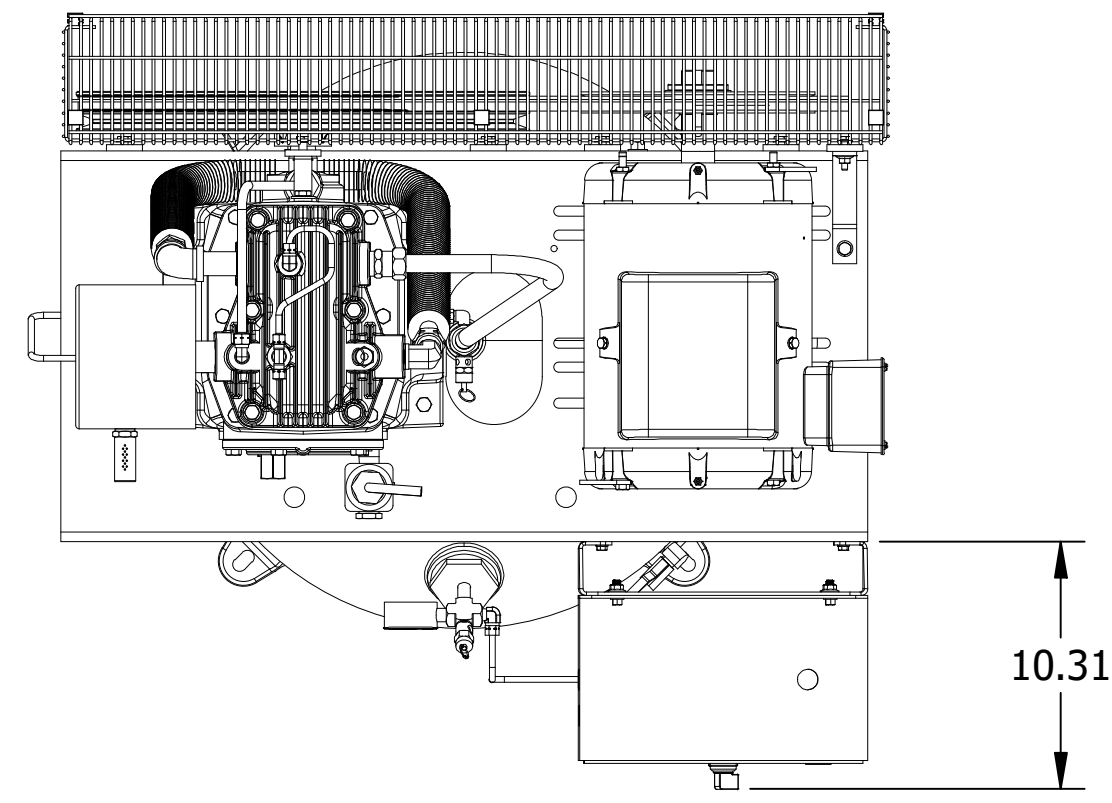

SIMPLEX CONTROL PANEL (N1/N4)

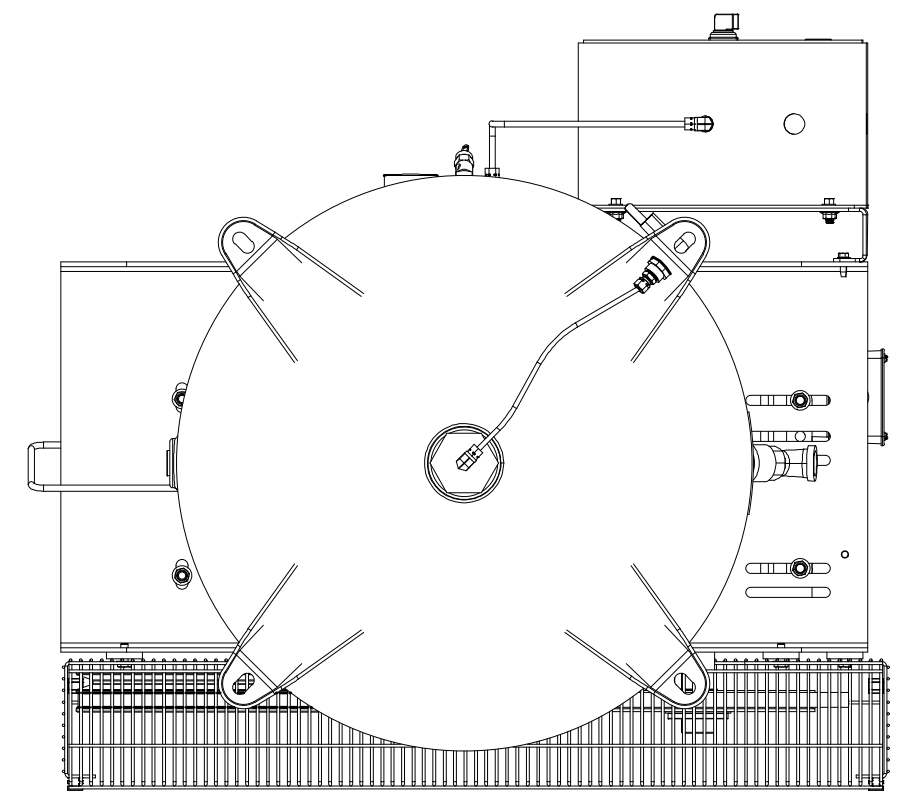
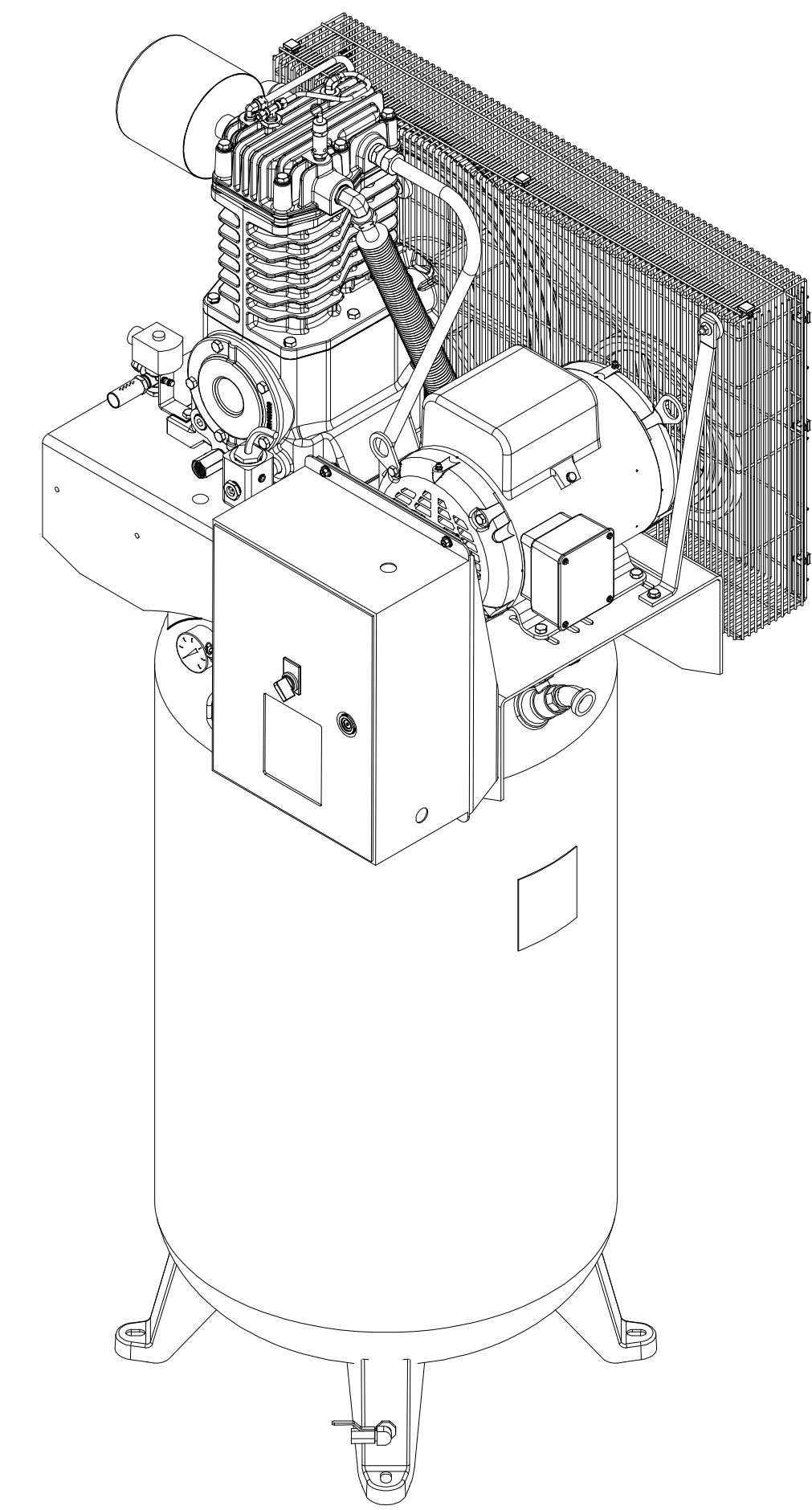
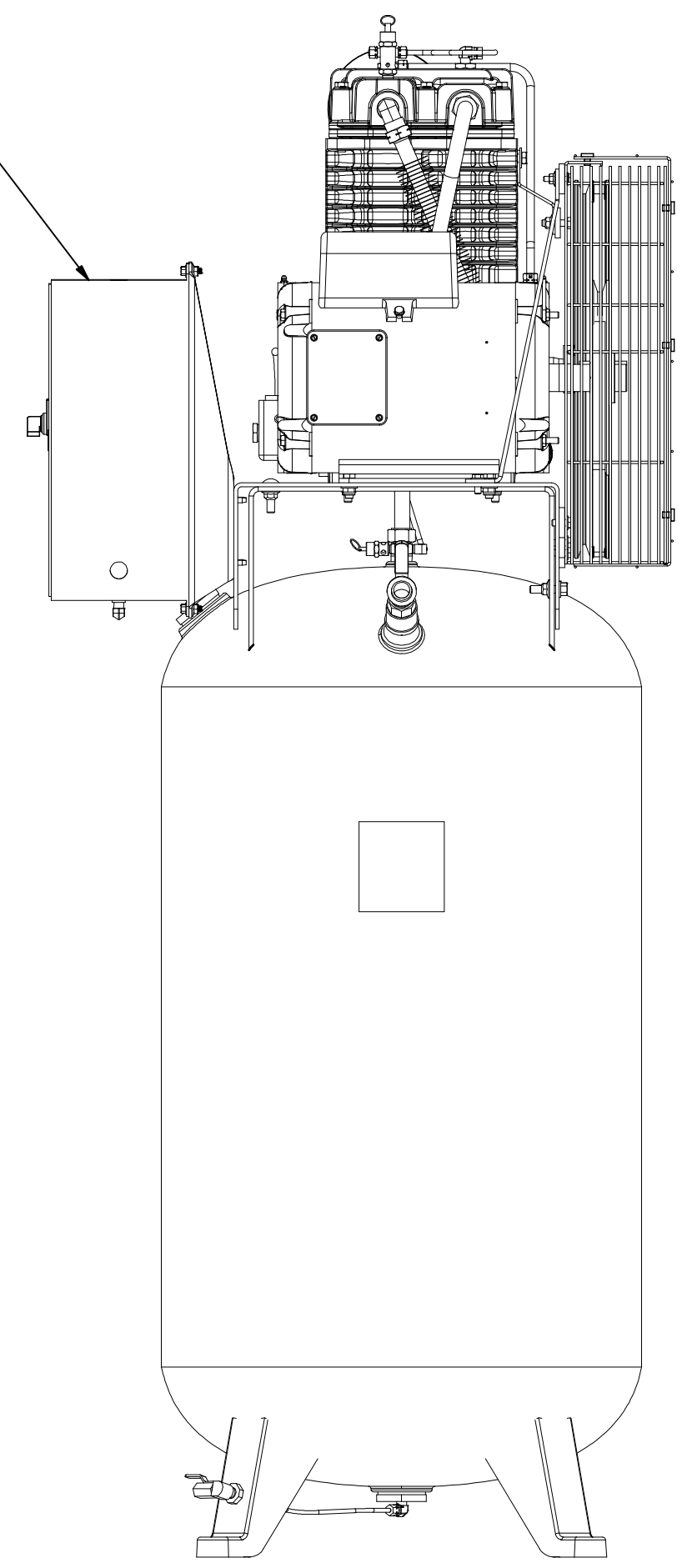

CONFIDENTIAL: This document is property of Atlas Copco, LLC and shall not without our permission be copied, used for manufacturing or communicated to any other person or company.

Name		DWG.DIM.CRS/CRP-1,80V		Confidentiality Class		1102K Internal	
Material		Not Applicable		Finish		Not Applicable	
Scale		1:8		Family		D	
Drawn by		UTYBALKER		Make From		Replaces	
Version Drwg		Blank wt		Ib		Fini wt	
Des checked		Prod checked		Approved		Date	
Parent 3D model		Ed . Version 3D		Approved Internal		Date 7/04/2022	
STATUS		Approved Internal		Designation		Sheet 5 / 5	
2022035412		2022036153		Drawing owner		UTY	