

FEATURES

- Non-contact design
- Dry (oil-free) pumping chamber
- Air-cooled & direct driven
- Simple, Modular Construction
- Suitable for Variable Speed Applications



The Airtech VCX positive displacement rotary claw design is air cooled, dry-running and noncontacting. These features, along with quality construction results in a vacuum pump that is extremely high in reliability and a long service life. The non-contact design eliminates internal wear and maintenance. No water levels to check due to air-cooled operation and no sealing or lubricating oil is needed in the pumping chamber.

The claw shaped rotors inside the pump housing rotate in opposite directions, compressing the air and discharging through a silencer to the atmosphere. The anti-suck back valve in the inlet flange prevents back flow into the pumping chamber. The two rotors are synchronized by gears that are oil lubricated to facilitate a long gear life.

PERFORMANCE CURVE

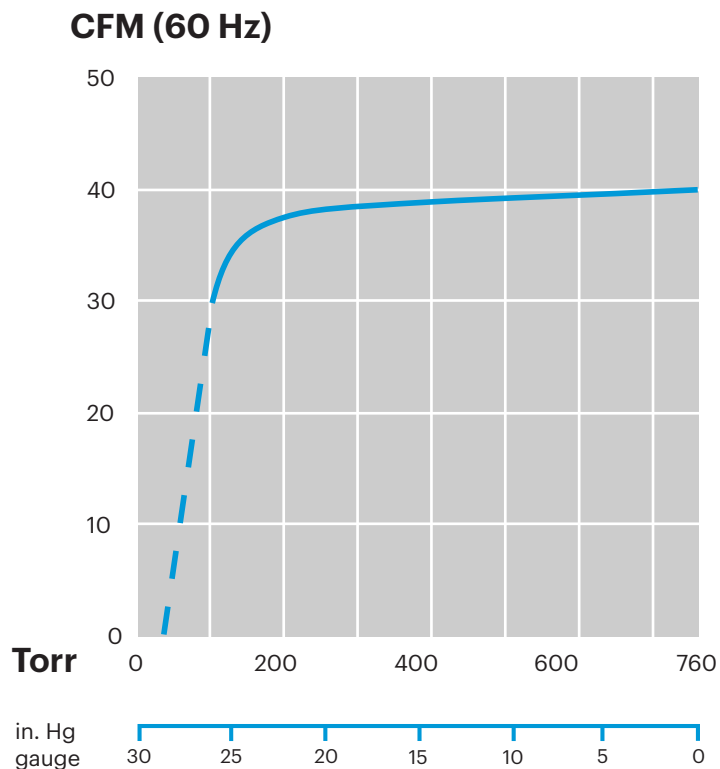

Specifications are subject to change without notice. Please contact factory for specification updates.

DIMENSIONS (INCHES)

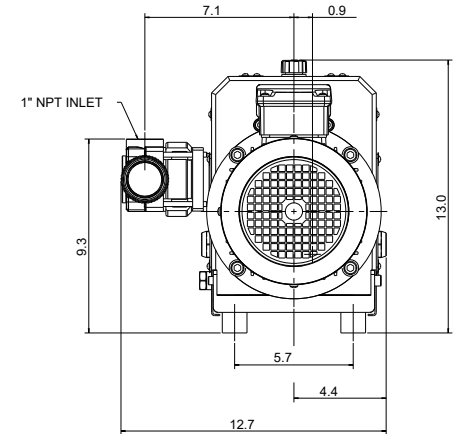
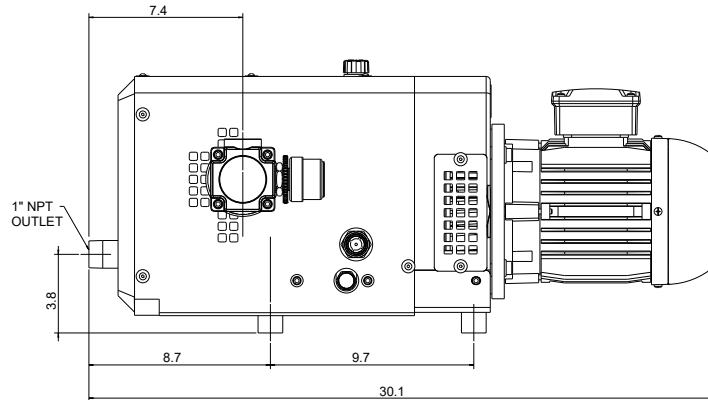

PERFORMANCE DATA

Model	VCX 60
Capacity [CFM]	40
Ultimate vacuum (in. Hg)	28.44
Ultimate vacuum (continuous operation)	27
Motor Rating (HP)	2
Speed (RPM)	3450
Voltage	208-230/460
Full load amperage	8.1-7.6/3.8
Oil capacity (qt.)	0.6
Average noise level (dB[A])	80
Inlet/outlet connections	1"
Weight (lbs)*	132

*Depends on motor manufacturer

AIRTECH, INC.

RUTHERFORD, NJ 07070
WWW.AIRTECHUSA.COM
TEL: (888) 222-9940
FAX: (201) 569-1696