



**Air System
Products**
Filtration Group®

Accu-Drain

Installation & Operation Manual



🏠 AIR SYSTEM PRODUCTS
51 Beach Ave.
Lancaster, NY 14086

☎ 716/683.0435
✉ ASPSalesTeam@airsyspro.com
🌐 www.airsyspro.com

Models ACD3 & ACD5
Electronic Demand Condensate Drain

INSTALLATION INSTRUCTIONS FOR ACCU DRAIN

INTRODUCTION

The ACCU DRAIN is designed for trouble-free and maintenance free draining of unwanted accumulations of condensation and other foreign matter from any collection point in a compressed air system. The condensation can enter through the top or bottom of the drain's reservoir. As the reservoir fills up, a stainless steel float rises with the fluid until it actuates an upper level reed switch. The switch signals a relay that opens the POSI VALVE (our proprietary sliding gate solenoid valve). The valve stays open until the float returns to the bottom, where a lower level reed switch closes the valve without wasting any air.

INSTALLATION

CAUTION: COMPRESSED AIR CAN BE DANGEROUS. Before attempting to install the drain, be certain that the pressure vessel on which the drain will be installed is completely depressurized.

The drain should not be installed in areas that are exposed to freezing temperatures. Be certain that the air system pressure does not exceed the 200 PSI working pressure of the drain.

Connecting the drain to the air system should be done by using one of the recommended installation diagrams shown herein. The installation of a strainer is not required or recommended.

Install the drain as close to the source to be drained as possible. Since the ACCU DRAIN uses gravity to fill the reservoir, the entire drain must be installed below the vessel to be drained when using the top inlet. If flexible tubing is used on the discharge, be certain it is properly fastened to prevent it from whipping when the drain discharges the condensation.

The ACCU DRAIN will accept condensation from either the top or the bottom inlet of the reservoir. Where possible, we recommend the condensation enter through the bottom and a vent line be installed in the top inlet port. The other end of the vent line should be installed at a point of equal or lower pressure. This will insure that the air in the reservoir will properly exit as the condensation fills the tank and replaces the air.

If the top inlet is used, then the bottom inlet must be plugged with a 1/2" NPT plug (not provided). In addition, the drain should be installed as close to the source being drained as possible. Any reduction in pipe size is not recommended. When using the top inlet, the ACCU DRAIN reservoir cannot be higher than the bottom of the vessel that is being drained.

Check voltage on label and apply power to the drain.

Close the By-Pass drain valve and open the Shut-Off valve. The pressure vessel can now be repressurized.

CHECKING THE DRAIN'S OPERATION

Testing the ACCU DRAIN can be done by pushing the TEST button.

After installation is complete and the drain is on line, a check should be made that the condensation is properly entering the reservoir. This can easily be done by looking through the transparent reservoir.

If condensation is not entering the reservoir, check for the following:

Push the test button on the control panel to see if any condensation is drawn into the reservoir. If condensation is drawn in, then check items 2, 3, and 4. If no condensation is drawn in check items 1, and 5.

1. Make sure the auxilliary shut off valve is open.
2. Do not use the bottom inlet on the ACCU DRAIN without installing a vent line (above the water line.)
3. If a vent line is installed, make sure that it is at or down stream from the vessel that is being drained.
4. Be certain that the ACCU DRAIN reservoir is not higher than the vessel that is being drained. This is very important when using the top inlet on the ACCU DRAIN reservoir.
5. Check to make sure that the vessel being drained has condensation in it.

If the top inlet is being used and no condensation is entering the ACCU DRAIN reservoir, and all the above items have been checked, then we recommend that the bottom inlet be used with a vent line out of the top.

WARRANTY

The ACCU DRAIN is warranted to be free from defects in workmanship and materials for a period of one year from the date of shipment. The liability of the manufacturer is limited to repair or replacement of the drain at its option. In no event shall the manufacturer be liable for special or consequential damages or for delay in performances of this warranty.

CAUTION: Any attempt to repair the drain without authorization will void any warranty.

INSTALLATION DIAGRAMS ON REVERSE SIDE

Manufactured by:

AIR SYSTEM PRODUCTS, INC. ● 51 Beach Ave., Lancaster, NY USA ● Phone 716-683-0435 Fax 716-683-7128

IN GENERAL

The ACCU DRAIN is designed for compressed air systems. The ACCU DRAIN relies on gravity to fill its reservoir. In order for the condensate to properly enter the ACCU DRAIN reservoir, it must be installed at a point lower than the bottom of the vessel to be drained. Attempt to keep the piping run short, while positioning the ACCU DRAIN as close as possible to the drainage point. Run the piping in a continuously sloping manner while avoiding any pockets where condensate might collect. Always use non-galling pipe sealant. The use of unions and shut-off valves are recommended wherever possible.

VENTING / BALANCE LINE

Allowing the air to exit the ACCU DRAIN's reservoir as the condensate enters is critical for proper operation. The unit will "air-lock" and not work properly if that exchange cannot take place.

Installing a balance line is often necessary when it is not possible to adapt the ACCU DRAIN directly to the vessel. It may also be required when sudden surges of condensate are heavy enough to "air-lock" the ACCU DRAIN's reservoir. Connecting the balance line back to a point in the system where the pressure is "equal-to or lesser-than" the drain point will allow the condensate to fill the reservoir while eliminating the possibility of an "air-lock" condition.

APPLICATIONS

The drawings are suggested methods for installing the ACCU DRAIN.

Drawing #1

Prefilters, Coalescing filters, Moisture Separators, Drip Legs.

Drawing #2

Large Prefilters, Coalescing filters, Moisture Separators.

Drawing #3

Air Receiver Tanks.

Drawing #4

Refrigerated Air Dryers. This is the preferred method of installation when it is not possible to return the vent line back to the vessel being drained on Refrigerated Air Dryers. This method prevents re-introducing water vapor back into the dried air stream which would elevate the pressure dewpoint. (See Note below.)

NOTE: When opting to use Alternative Installation Method #4, it is necessary to adjust the "bleed" rate. The object here is to allow a small amount of compressed air to bleed through the Needle valve to atmosphere. This allows the condensate to enter the ACCU DRAIN without "air-locking" the reservoir. The following procedure applies when adjusting the "bleed" rate for Drawing #4.

- 1) Close the needle valve. Then pressure ACCU DRAIN.
- 2) Slowly open needle valve until you can feel air exiting.
- 3) When the water level is visible, adjust the needle valve to control the bleed rate. Slowly open or close the needle valve until you see the water line ripple as the air breaks through.
- 4) A small amount of air exiting the needle valve verifies proper adjustment.

Dwg. 1

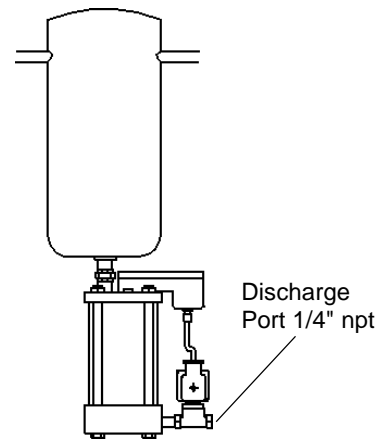

Dwg. 2

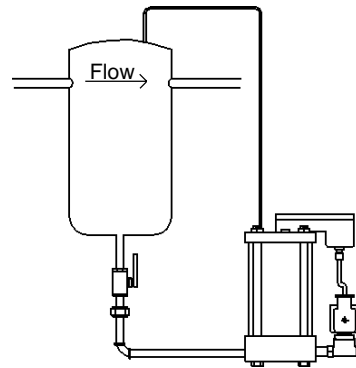

Dwg. 3

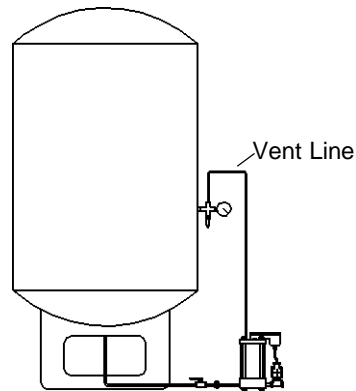

Dwg. 4

