

REVISION HISTORY				
ZONE	REV	DESCRIPTION	DATE	CHK
	A	RELEASED PER ECN 1059437		

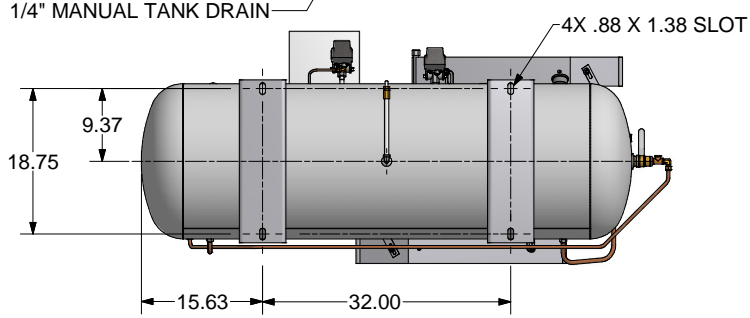
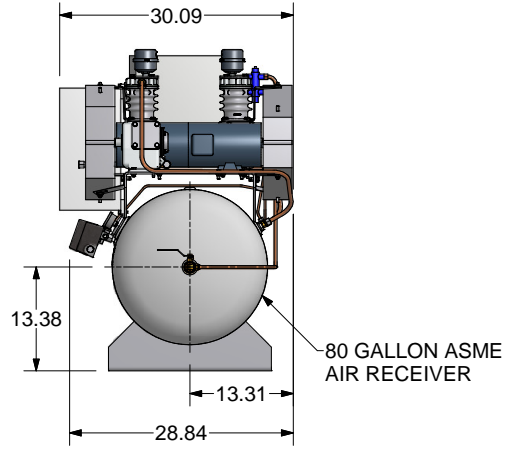
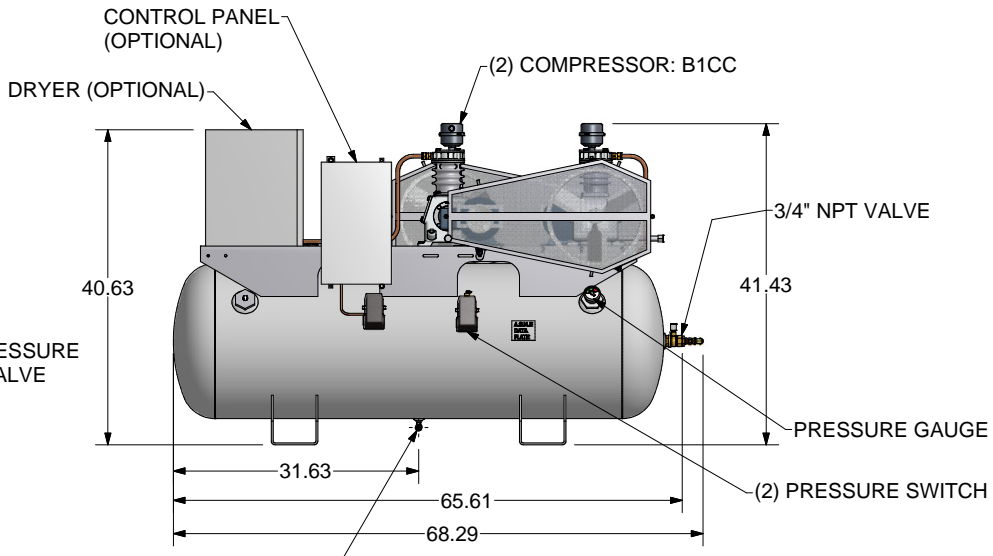
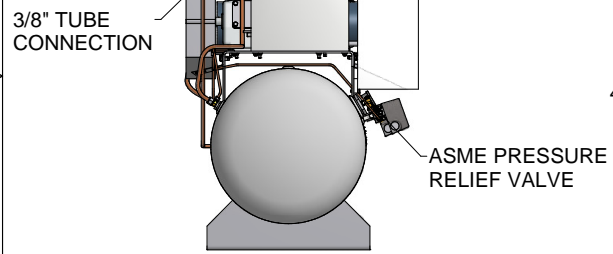
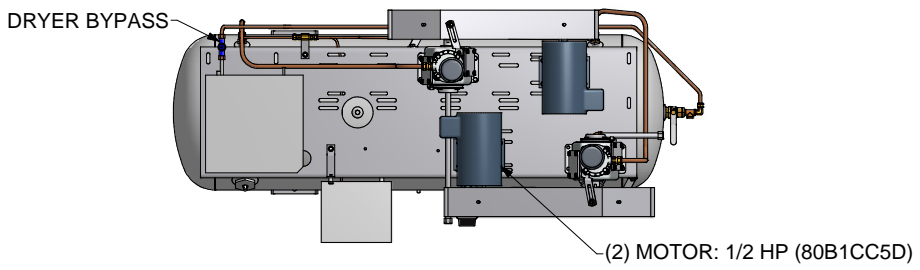
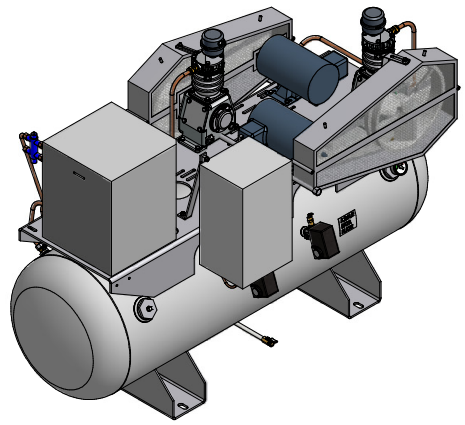

FINISH OF CHAMFERS AND FILLETS TO CONFORM TO ROUghest ADJACENT AREA.  
 SURFACE ROUGHNESS MAXIMUM PER ASME B46.1.  
 FULL THREAD DEPTHS ARE MINIMUM.

UNLESS OTHERWISE SPECIFIED DIMENSIONS ARE IN INCHES  
 TOL. ON DECIMALS: X = ± .05  
 TOL. ON DECIMALS: XX = ± .02  
 TOL. ON DECIMALS: XXX = ± AS SPECIFIED  
 TOL. ON ANGLES: ± 0°-30'

THIRD ANGLE PROJECTION

CONFIDENTIAL - THE INFORMATION CONTAINED IN THIS DOCUMENT IS THE PROPERTY OF GARDNER DENVER, INC. IT IS NOT FOR PUBLIC DISCLOSURE. POSSESSION OF THE INFORMATION DOES NOT CONVEY ANY RIGHT TO LOAN, SELL OR DISCLOSE THE INFORMATION. UNAUTHORIZED REPRODUCTION OR USE OF THE INFORMATION IS PROHIBITED. THIS DOCUMENT IS TO BE RETURNED TO GARDNER DENVER, INC. UPON THE COMPLETION OF THE PURPOSE FOR WHICH IT IS LOANED OR UPON REQUEST.

DIMENSIONING AND TOLERANCING PER ASME Y14.5-2009  
 THREADS PER ASME B1.1 GAGING SYSTEM 21 U.O.S., ANSI B1.20.1 & B1.20.3

<b>Gardner Denver</b>		HEAT TREATMENT		ENG. REF:	
Gardner Denver Inc. Quincy, IL		TITLE		80B1CC5D	
DWN BY: KWT 4/29/2011		SCALE		310CFD800	
CKD BY: DA 4/29/2011		SCALE		1/B	

SHEET 1 OF 1